

How to Read the Operation Manuals

The following operation manuals are supplied with this camera. Refer to the appropriate manual for instructions relating to the required operation.

Open the package



Check the contents of the package. (p.2)

Basic operation



Digital Camera Operation Manual (this manual)

This manual explains how to operate the camera, from the preparations that are necessary before using the camera to instructions on how to use the various shooting functions and play back files.

Transfer images to PC

(Supplied by Software Operation Manual for Caplio RR1 CD-ROM)

Caplio Utility

Windows/Macintosh

This manual explains how to install the necessary software, how to connect the camera to the PC, and how to transfer files between the camera and the PC.

Checking the Package Contents

Check that your digital camera comes complete with the following items. Read the warranty card and keep it in a safe place.

- Caplio RR1

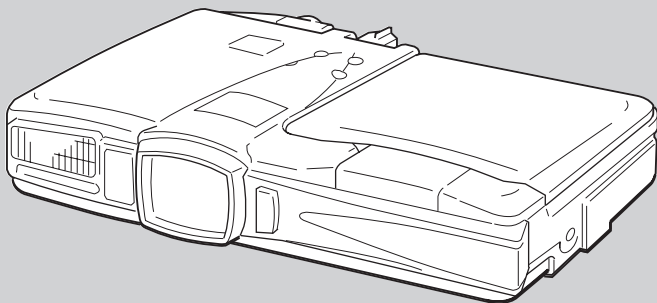

- Lens cap



- Soft case

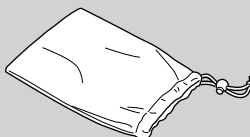

- Battery (rechargeable lithium ion battery)

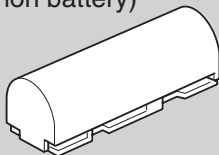

- Battery charger

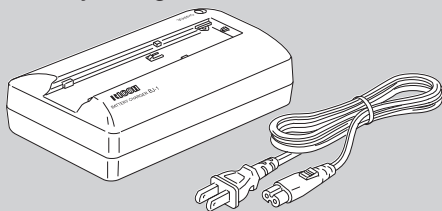

- AV interface cable

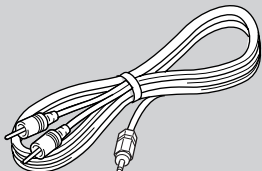

- USB cable

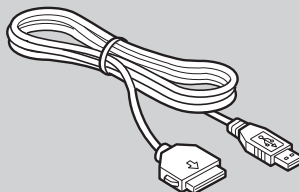

Wrist strap

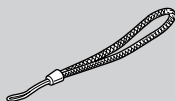

Software CD-ROM

Software Operation Manual for
Caplio RR1 (CD-ROM)

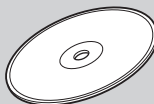

Operation manual (this manual)

Warranty card

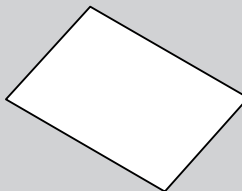

CONTENTS

How to Read the Operation Manuals	1
Checking the Package Contents	2
CONTENTS	4
Parts & Names	8
Basic Operation/Quick Reference	10
Preparations	10
Shooting	11
Playback	12
Erasing	13
Safety Precautions	14

Chapter 1 GETTING STARTED

Before Using the Camera	20
Attaching the Wrist Strap	20
Attaching the Lens Cap	20
Powering the Camera	21
Charging the Battery	21
Loading the Battery	22
Connecting an AC Adapter	25
SmartMedia Memory Cards	26
What is a SmartMedia Memory Card?	26
Inserting a SmartMedia Memory Card	27
Turning the Camera On and Off	30
How to Use the Mode Dial	31
Explanation of Information Displays	32
Shooting Mode Display	32
Playback Mode Display	33
Menus	34
Setting the Date and Time	37
How to Hold the Camera	40
Adjusting the Camera	42
Diopter Adjustment	42
Adjusting the Brightness of the LCD Monitor	42

Chapter 2 SHOOTING

Basic Shooting	44
Operation Flow	44
Selecting a Shooting Mode	45
Selecting a Recording Destination	46
Selecting an Image Quality Mode	47
Checking the Position of the Subject	48
Setting the Size of the Subject (Zoom)	50
Shooting (Still Picture Mode)	51
Special Shooting Functions	55
Text Shooting	55

Sound Recording	56
Continuous Shooting	56
Motion Picture Recording	57
Still Picture/Text Shooting with Sound	58
Changing Flash Modes	60
Setting the Exposure Compensation	62
Changing the White Balance	64
Using the Self-Timer	67
Close-up Shooting (Macro Mode)	68
Setting the Focus	70
Red-Eye Reduction Mode	72
Changing the ISO Setting	73
Date Imprinting	74
Split-Screen Mode	75
Sharpness Mode	79
Monochrome Mode	80
Negative Mode	81
Interval Shooting	82
Auto Bracket Shooting	83
Switching to Non-compressed Mode	84
Changing the Exposure Metering System (Photometry)	86
Increasing the Shutter Speed (S Mode)	87
Setting the Time Exposure Mode	88

Chapter 3 **PLAYBACK**

Before Starting to Playback Recorded Images	90
Files That Can Be Played Back on the Camera	90
Connecting to a TV	90
Playing Back a File	92
Playing Back a Still Picture/Text/Continuous File	92
Playing Back a Sound File	95
Playing Back a Motion Picture File	96
Special Playback Functions	98
Multi Image Playback	98
Zoom Playback	99
Auto Playback	100
Cropping	101
Copying Image Files	103
Playing a File Shot with a Non-Ricoh Camera	104
Rotating a Displayed File	105
Protecting a File	106
Setting Printing Services (DPOF)	107

Chapter4 **ERASING**

Erasing Files	114
Erase Single Image	114
Erase All Images	115
Erase Selected Images	116

Chapter 5 SETTINGS/MISCELLANEOUS

Changing Camera Settings	120
Formatting a Card/Internal Memory	120
Keep Settings	121
Changing LCD Confirmation Time	122
Auto Power Off Setting	123
Beep Sound Setting	124
Power Save Mode Setting	124
Changing the File Numbering System	125
Changing Video-Out Signal Method (NTSC/PAL)	126
Changing Display Language	127
Initializing Settings	127
Using the Remote Control	129
Shooting	129
Playing	131
Erasing	132

APPENDIX

Troubleshooting	136
Error Messages	140
Recording Capacities	142
Accessories	143
Using Your Digital Camera in Other Countries	144
Handling Precautions	145
Care and Storage	146
Specifications	147
About the Warranty and Servicing	149
Index	152
Alphabetical Index	152
Functional Index	154



Tips to Extend Recording and Playback Times	23
Auto Power Off	30
How to check the date and time	39
LCD Monitor Display (Shooting Mode)	46
Focus Lock Shooting	54
Remote Control	68
Shutter Release Button	69
Slow Shutter	87
Adding a Sound to a File being Played Back	94
LCD Monitor Display (Playback Mode)	97

■ Meaning of Symbols

	This indicates points or restrictions relating to operation requiring your attention.
	This indicates a supplementary explanation of the operation concerned or points you should know.
	This indicates information that it is useful to know when operating the camera.
	This indicates the reference page for the function or operation concerned.

Parts & Names

■ Camera Body

Front

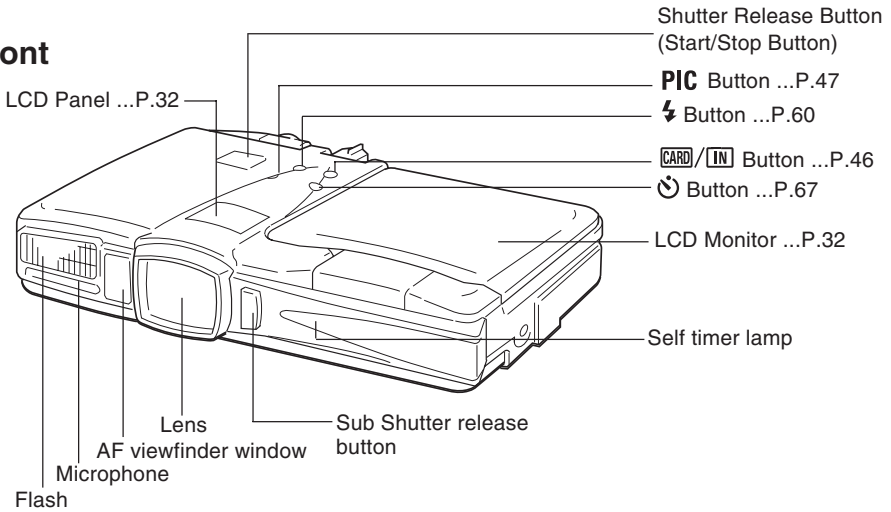

Back

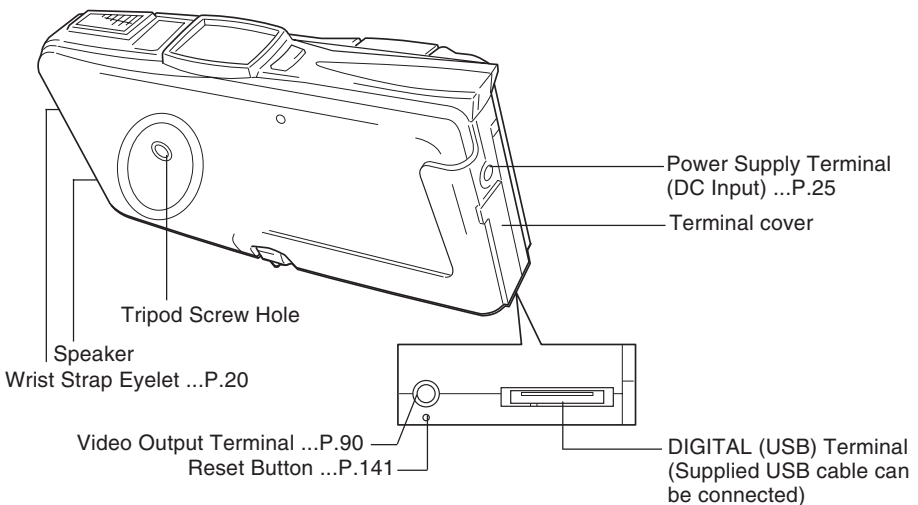

Operation

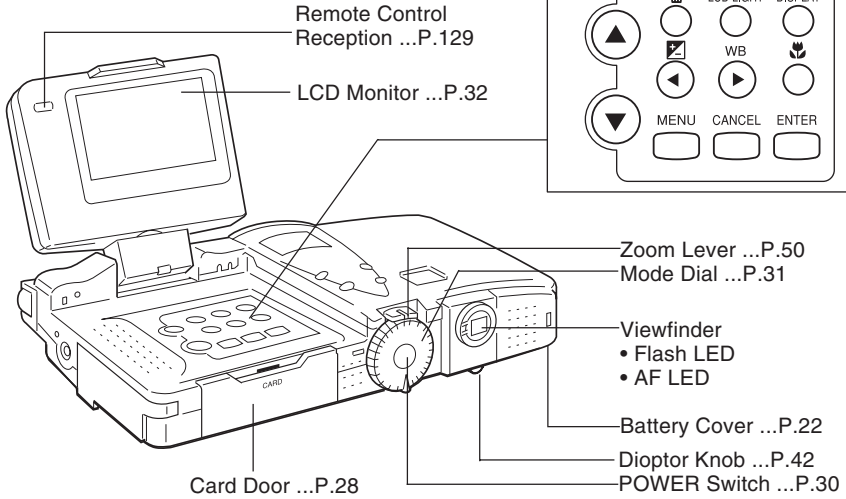

■ Battery/Battery Charger

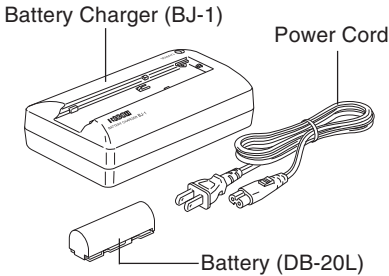

■ AC Adapter (optional)

• AC-3 (100V – 240V)

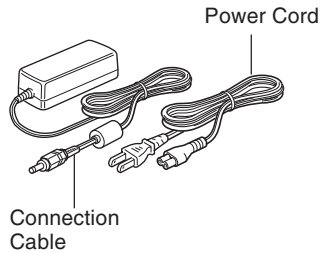

■ SmartMedia Memory Card (optional)

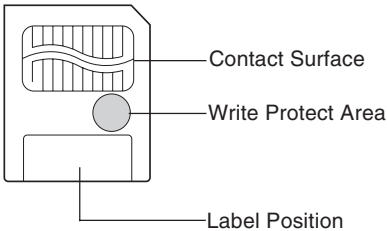

■ Remote Control Unit (optional)

• DR-3

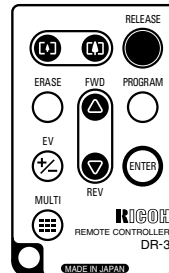

Basic Operation/Quick Reference

This section provides introductory information for operating the digital camera. Further details can be found in the reference pages mentioned below.

Preparations

Powering the Camera (p.21-25)

1 Load the battery into the camera.

* When using an AC adapter, connect it to the camera and then to the AC outlet.
(p.25)

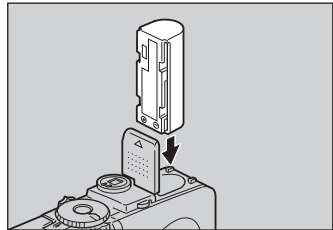
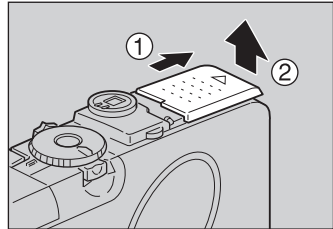

Inserting a SmartMedia Memory Card (p.26-29)

- 1 Make sure that the camera is turned off.**
2 Open the card door and insert a SmartMedia memory card.

* Before using a new SmartMedia memory card, you must first format (initialize) it with the camera. (p.120)

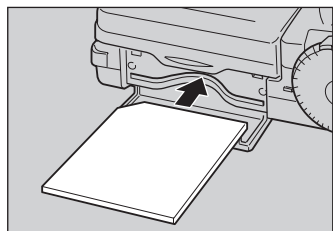
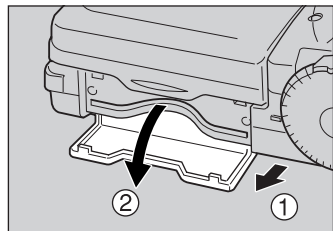

Setting the Date and Time (p.37-39)

- 1** Turn the power switch on and set the mode dial to [SET].
- 2** Press the or button to select [DATE SETTING].
- 3** Press the DISPLAY button to select the display method.
- 4** Press the ENTER button.
- 5** Press the or button to change the highlighted digit.
- 6** Press the or button to select the digit you wish to change.
Repeat steps 5 and 6 above to complete the settings.
* Each time you press the or button, the flashing digit changes, from year to month, day, hour and minute.
- 7** After you have set the date and time, press the ENTER button.

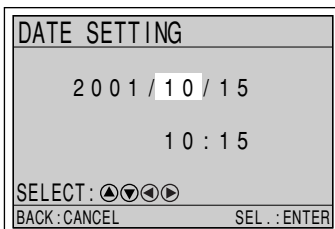
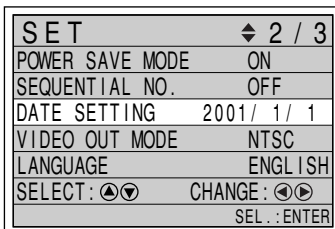



Shooting



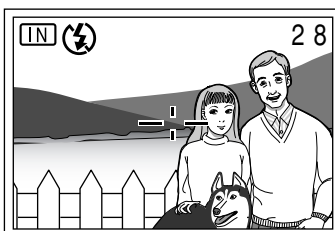
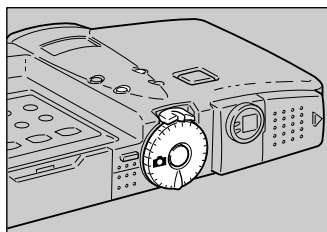

Basic Shooting Procedure (Still Picture Mode) (p.45-54)

- 1** Turn the power switch on and set the mode dial to [].
- 2** Press the button to select the recording destination.
- 3** Press the PIC button to select an image quality mode.
- 4** Move the zoom lever to select the desired size of the subject.
Move to to increase the size of the subject and move to to decrease the size of the subject.
* Check the position of the subject by looking through the viewfinder or at the LCD monitor.
- 5** Press the shutter release button.



Changing the Flash Mode (p.60-61)

- 1 Set the mode dial to [] or [].
- 2 Press the  button to select a flash mode.

You can choose Flash Off (), Auto (), Forced Flash (), or Slow Synchro mode ( blinks).

The mark for the selected mode will be displayed on the LCD panel and on the LCD monitor.

- 3 Press the shutter release button.

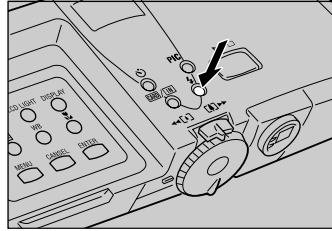
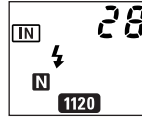

Using the Self-Timer (p.67)

- 1 Set the mode dial to [] or [].
- 2 Press the  button.

The  mark will be displayed on the LCD panel and on the LCD monitor.



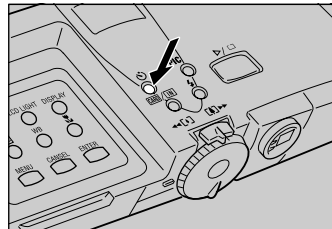
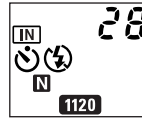

- 3 Press the shutter release button.

The self timer lamp lights and the self-timer starts. The shutter is released after a delay of approximately 10 seconds. The self timer lamp starts to flash about 2 seconds before the shutter is released and the beep sound is heard.



Playback

Playing Back Files (Still Image Files) (p.92-94)

- 1 Turn the power switch on and set the mode dial to [].
- 2 Press the  button to select the playback source.
- 3 Press the  or  button to select a file.

* The zoom playback and multi-image playback allow you to magnify an image or view several image files at once. (p.98-101)

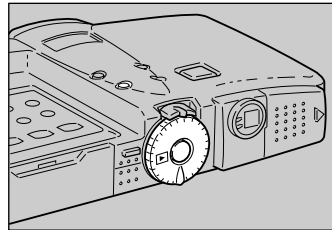



Erasing

Erasing Files (p.114-117)

1 Press the **POWER** switch to turn the camera on and set the mode dial to [].

2 Press the  button to select the erase source.



3 Press the  button.

4 Press the  or  button to select the erase mode and press the **ENTER** button.

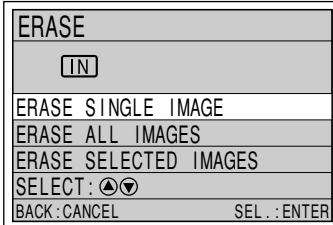
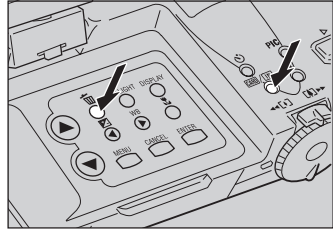
* Remember that files cannot be restored once they are erased. Before starting to erase a file, make sure that you want to erase it.



If you selected [ERASE SINGLE IMAGE]

5 Press the  or  button to select a file you want to erase and press the shutter release button.

Repeat step 5 to erase additional images one at a time.

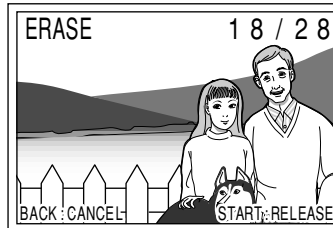

If you selected [ERASE ALL IMAGES]

5 Press the shutter release button.

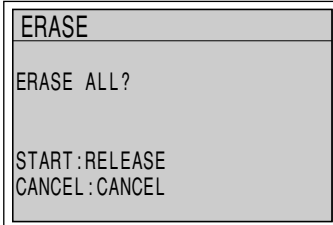

If you selected [ERASE SELECTED IMAGES]

5 Press the  or  button and the  or  button to select a file you want to erase and press the **ENTER** button.

Repeat step 5 to select additional files. To cancel the erase setting, press the **ENTER** button again.



6 Press the shutter release button.

Safety Precautions

Warning Symbols

Various symbols are used throughout this instruction manual and on the product to prevent physical harm to you or other people and damage to property. The symbols and their meanings are explained below.

Danger

This symbol indicates items that may imminently lead to death or serious injury if ignored or incorrectly handled.

Warning

This symbol indicates matters that may lead to death or serious injury if ignored or incorrectly handled.

Caution

This symbol indicates matters that may lead to injury or physical damage if ignored or incorrectly handled.

Sample Warnings



The  symbol alerts you to actions that must be performed.



The  symbol alerts you to prohibited actions.

The  symbol may be combined with other symbols to indicate that a specific action is prohibited.

● **Examples**



Do not touch



Do not disassemble

Observe the following precautions to ensure safe use of this equipment.

Danger



- Do not attempt to disassemble, repair or modify the camera.

The high voltage circuitry in the equipment may lead to electric shock.



- Do not attempt to disassemble, modify or directly solder the battery.

Danger



- Do not dispose of the battery in fire, subject it to heat, or use or leave it where it is exposed to high temperature, such as near fire or inside a car. Keep away from water and do not allow it to get wet.



- Do not pierce the battery with a needle, hit it with a hammer, tread on it, drop it or subject it to severe impact.



- Do not use the battery if the outer casing is damaged or it is suspiciously deformed.

Warning



- Turn off the power immediately in the event of irregularity, such as the equipment emitting smoke or a strange smell. Remove the batteries as soon as possible, being careful to avoid electric shocks or burns. If you are drawing power from a household electrical outlet, be sure to unplug the power cord from the outlet to avoid fire or electrical hazards. Discontinue use of the equipment immediately if it is malfunctioning. Contact the nearest service center at your earliest convenience.



- Turn off the power immediately if any metallic object, water, liquid or other foreign object gets into the equipment. Remove the batteries as soon as possible, being careful to avoid electric shocks or burns. If you are drawing power from a household electrical outlet, be sure to unplug the power cord from the outlet to avoid fire or electrical hazards. Discontinue use of the equipment immediately if it is malfunctioning. Contact the nearest service center at your earliest convenience.

Warning



- Avoid any contact with the liquid crystal inside the LCD monitor, should the monitor be damaged. Follow the emergency measures below in the following circumstances.
 - SKIN: If any of the liquid crystal gets on your skin, wipe it off and rinse the affected area thoroughly with water, then wash well with soap.
 - EYES: If it gets in your eyes, wash your eyes with clean water for at least 15 minutes and seek medical advice immediately.
 - INGESTION: If any of the liquid crystal is ingested, rinse the mouth out thoroughly with water. Have the victim drink a large amount of water and induce vomiting. Seek medical assistance immediately.



- Follow these precautions to prevent the battery from leaking, overheating, igniting or exploding.
 - Do not use a battery other than that specifically recommended for the equipment.
 - Do not carry or store the battery with metallic ballpoint pens, necklaces, coins, hairpins, etc.
 - Do not put the battery in a microwave or high voltage equipment.
 - Remove the battery from the camera immediately and keep away from fire in the event of irregularity during use or recharging, such as leakage of the battery fluid, discoloration, or strange smell.



- Observe the following precautions to avoid the risk of fire, electric shock or bursting due to charging of the battery.
 - Do not use a power source voltage other than that indicated. Avoid putting several loads on one power outlet or using an extension cable.
 - Do not cut, damage, tie in a bundle or alter the power cord. Do not place heavy objects on the power cord, pull it or bend it excessively.
 - Do not plug or unplug the power cord with wet hands. When unplugging the power cord, be sure to hold the plug.
 - Do not wrap the battery in cloth, etc.

Warning



- Keep the battery used in this equipment out of the reach of children to prevent accidental ingestion of harmful substances. Consumption of battery fluid is extremely harmful to human beings. If swallowed, seek immediate medical assistance.



- Keep the equipment out of the reach of children. Their inability to read and understand warnings and safety precautions may lead to accidents.



- Do not touch the internal components of the equipment if they become exposed as a result of being dropped or damaged. The high-voltage circuitry in the equipment could lead to an electric shock. Remove the batteries as soon as possible, being careful to avoid electric shocks or burns. Take the equipment to your nearest dealer or service center if it is damaged.



- Do not use the equipment in the bathroom or shower as this could result in fire or electric shock.



- Do not use the equipment near flammable gases, gasoline, benzene, thinner or similar substances to avoid the risk of explosion, fire or burns.
- Do not use the equipment in aircraft or other locations where usage is restricted or prohibited as this may lead to disasters or accidents.



- Wipe off any dust that accumulates on the electrical plug as this may lead to fire.
- Use only the specified AC adapters for this equipment (AC-3) in household electrical outlets. Other adapters pose the risk of fire, electric shock or injury.



- To avoid the risk of fire, electric shock or injury, do not use the AC adapter with commercially available electronic transformers when traveling abroad.

Observe the following precautions to ensure safe use of this unit.

 **Caution**



- Contact with fluid leaking from a battery can lead to burns. If part of your body comes in contact with a damaged battery, wash the area with water immediately. (Do not use soap.) If a battery starts to leak, remove it immediately from the equipment and wipe the battery chamber thoroughly before replacing it with a new battery.



- Plug the power cords securely into the electrical outlets. Loose cords pose a fire hazard.



- Do not allow the camera to get wet. In addition, do not operate it with wet hands. Both pose the risk of electric shock.



- Do not fire the flash at drivers of vehicles, such as bicycles, cars and trains, as this may cause the driver to lose control and result in a traffic accident.

Safety Warnings for Accessories

- Safety warnings for the optional accessories, such as the AC adapter, are contained in the instruction manual provided with each product and should be read thoroughly before operating the equipment.