

## Oscillator frequency calibration with CL=12.5pF crystal and Ricoh RTC IC

Ricoh recommends to use CL=6pF to 8pF crystal with our RTC. On the other hand, some crystal vendors offer CL=12.5pF crystal as their standard crystal. This document explains how to use CL=12.5pF crystal with Ricoh's RTC for its oscillator frequency calibration.

Items are as follows:

- Ricoh RTC lineup which is applied to this document
- What is the load capacitance of a crystal (CL)?
- The effect of using CL=12.5pF crystal with Ricoh's RTC
- How to adjust the clock frequency with the calibration function of Ricoh RTC
- How to evaluate the clock gain or loss
- Notes on using the oscillator calibration circuit

< Ricoh RTC lineup which is applied to this document >

This document is applied to the following Ricoh RTC lineup:

Table 1: The RTC applied to this document

	SSOP8	SSOP10	SSOP10G	TSSOP10G	FFP12	SSOP16
SPI (4 wire)	-	RS5C348A/B	RV5C348A/B	RT5C348B R2043T	R2043K	
3 wire	-	RS5C338A	RV5C338A RV5C339A	R2033T	R2061Kxx R2062Kxx R2033K	R2061Sxx
I <sup>2</sup> C Bus	RS5C372A/B	-	RV5C386A RV5C387A	R2051T01 R2023T	R2051Kxx R2023K	R2051Sxx

< What is the load capacitance of a crystal (CL)? >

Fig. 1 shows the typical oscillator circuit of CMOS clock IC. The load capacitance (CL) of the crystal is a critical parameter. The CL is not the capacitance of the crystal itself.

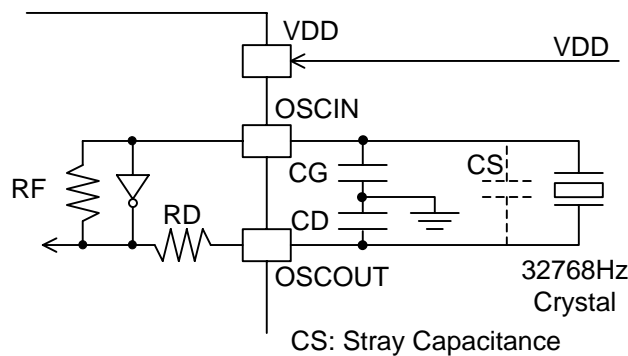

Fig.1: Typical Oscillation Circuit

When  $CS+CG \times CD / (CG+CD)$  is equal to CL, the crystal oscillates at its nominal frequency (32768Hz).

When  $CS+CG \times CD / (CG+CD)$  is bigger than CL, the crystal oscillates slower than 32768Hz.

And, when  $CS+CG \times CD / (CG+CD)$  is smaller than CL, the crystal oscillates faster than 32768Hz.

< The effect of using CL=12.5pF crystal with Ricoh's RTC >

The Ricoh's RTC ICs on the Table 1 incorporate CG and CD. These values are calculated and designed for CL=6 to 8pF crystal.

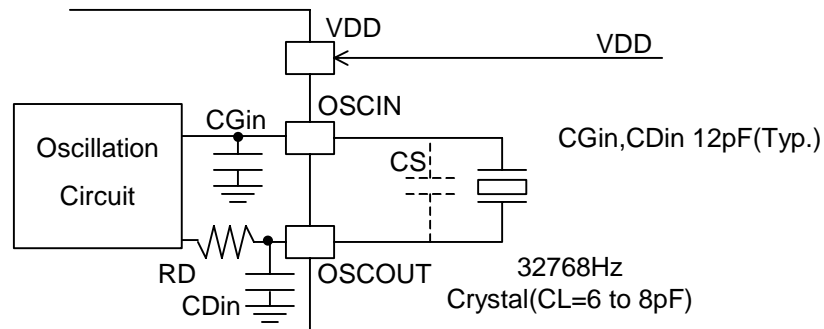

Fig.2: Oscillation Circuit for Ricoh's RTC

When we use 12.5pF crystal, and if CGout=CDout=12pF are added as in Fig 3, output frequency will be 32768Hz as in the previous formula. (CS=0.5pF)

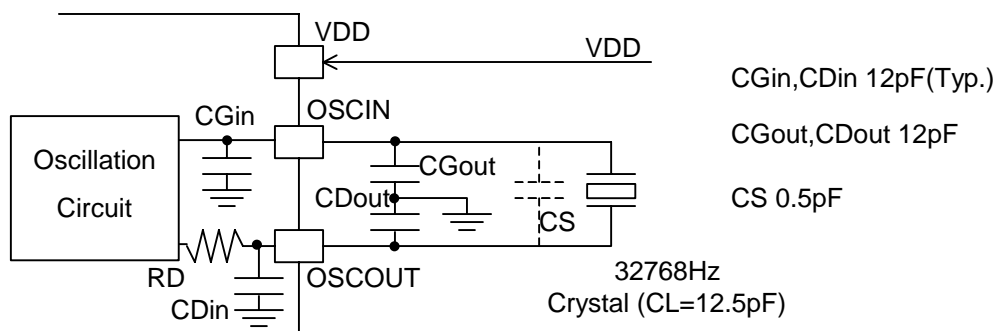

Fig.3: Oscillation Circuit for Ricoh's RTC and 12.5pF crystal

Experimented data for RV5C338A on this circuit is as follows:

Table 2: Characteristics for the circuit in Fig3

VDD=3v, Ta=25°C, Crystal is MS2V-TS (CL=12.5pF) (Micro Crystal)

	CGout=CDout=0pF (without using CGout and CDout)	CGout=CDout=12pF (with using CGout and CDout)
Frequency	32770.49Hz	32767.96Hz
Oscillation Frequency deviation (32768Hz as standard)	+75.99ppm (gains 204sec a month)	-1.22ppm (loses 3.3sec a month)
Time keeping current	0.35μA	0.53μA
Minimum time keeping voltage	0.90v	1.04v
Negative Resistance	-719kΩ	-164kΩ
Oscillation allowance	11.4 times	3.4 times

If 12.5pF crystal is used with CGout and CDout, our RTC oscillates at its very close frequency to the specified value.

But power consumption increases from 0.35μA to 0.53μA, minimum time keeping voltage decreases, oscillation negative resistance is worse, and oscillator margin decreases.

Most of crystal manufacturers recommend users to make the negative resistance of the oscillation circuit bigger enough against the equivalent series resistor of the crystal. Oscillator margin means the equivalent series resistor of the crystal (Refer to the specifications of the crystal.) plus negative resistance, and the sum divides by the equivalent series resistor. Generally it is 5.0times or more. If oscillation margin is around 3.4 times, this oscillator will oscillate in normal condition, but may halt under bad conditions such as low temperature. The definition of negative resistance and its measurement method are also written in the catalogs of the crystals. Ricoh recommends to use CGout<15pF and CDout=0pF.

< How to adjust the clock frequency with software calibration of Ricoh RTC>

If 12.5pF crystal is used without CGout and CDout, Ricoh's RTC will run approximately 80ppm faster than normal use, that is, 210sec every month. But Ricoh's RTC incorporates the clock adjustment circuit. To correct time error in the oscillation frequency of the crystal oscillator, the oscillation adjustment circuit is configured to allow correction of a time count gain or loss from the CPU within a maximum range of ±189ppm. The oscillation adjustment circuit can adjust 80ppm-gain clock used even if 12.5pF crystal is used for precision clock.

To correct time count gain, write the oscillation adjustment value calculated with the next formula to the oscillation adjustment register.

$$\text{Oscillation adjustment value} = (\text{oscillator frequency} - \text{target frequency}) \times 10 + 1$$

Generally, the temperature characteristics of the 32768Hz crystal oscillator describe a parabola of which peak is at 25°C. Therefore, to obtain the accurate clock under the average temperature, rather higher target frequency may be appropriate. (+1 to 6ppm higher than 32768Hz).

For example, in the Table 2, oscillator frequency is 32770.49Hz (CGout=CDout=0pF). When the desired frequency is 32768.05Hz, the oscillation adjustment value is  $(32770.49 - 32768.05) \times 10 + 1 = 25.4 \cong 25$ . "25" is described "19h" in hexadecimal numeral. "(00011001)" shall be written to address 7h.

< How to evaluate the clock gain or loss>

The oscillator adjustment circuit is configured to change time counts of 1 second on the basis of the settings of the oscillation adjustment register once in 20seconds. The oscillation adjustment circuit does not effect the frequency of 32768Hz-clock pulse output from the 32KOUT (CLKOUT) pin. Therefore, after writing the oscillation adjustment register, we cannot measure the clock error with probing 32KOUT (CLKOUT) clock pulses. The way to measure the clock error as follows:

- (1) Output a 1Hz clock pulse of Pulse Mode with interrupt pin
- Each RTC has different 1Hz output pin and the way to set the register.

Table 3: 1Hz output pin and the way to set the register for output 1Hz clock

	Setting	Output Pin
RS5C372A	Address Eh ← (00000011)	/INTRA(5pin)
RS5C372B		/INTR(5pin)
RS/RV5C338A	Address Eh ← (00XX0011)	/INTR(6pin)
RV5C339A		/INTRA(6pin)
RS/RV/RT5C348A/B, R2043T		/INTR(6pin)
RV5C386A/387A, R2023T		/INTRA(6pin)
R2043K, R2033K		/INTR(10pin)
R2023K		/INTRA(10pin)
R2051Kxx, R2061Kxx, R2062Kxx		/INTR(9pin)
R2051Sxx, R2061Sxx		/INTR(10pin)

(2) After setting the oscillation adjustment register, 1Hz clock period changes every 20seconds like Fig. 4.

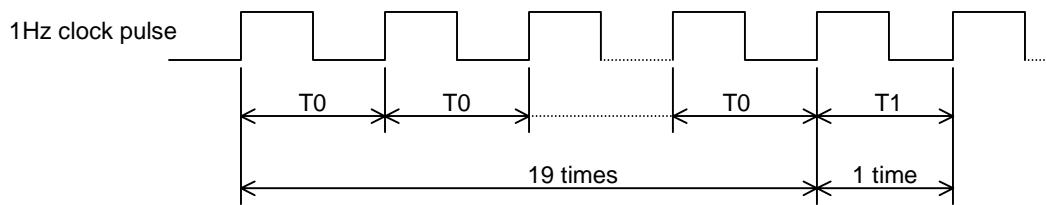

Fig.4

Measure the interval of T0 and T1 with frequency counter. A frequency counter with 7 or more digits is recommended for the measurement.

(3) Calculate the typical period from T0 and T1

$$T = (19 \times T_0 + 1 \times T_1) / 20$$

Calculate the time error from T.

Example: The time error for previous example. When oscillation frequency is 32770.49Hz and "19h" is set as the oscillator calibration value, T0 is 0.99992402s and T1 is 1.00138875s.

Then,  $T = (19 \times 0.99992402 + 1 \times 1.00138875) / 20 = 0.99999726$ .

Time error/day =  $(0.99999726 - 1) \times 60 \text{seconds} \times 60 \text{minutes} \times 24 \text{hours} = -0.24 \text{sec/day}$ .

We set the oscillation adjustment register to run clock just a little faster than nominal with considering crystal temperature characteristics. As a result, the actual time error is a little fast.

< Notes on using the oscillator calibration circuit >

When using the oscillator calibration circuit,

(1) Ricoh's RTC does not have non-volatile memory. Therefore, the system must store the oscillator adjustment value to non-volatile memory external of the RTC. The system must write the oscillation adjustment value to RTC, when setting the clock and calendar data.

(2) The oscillation adjustment circuit does not affect the frequency of 32768Hz-clock pulse output from the 32KOUT (CLKOUT) pin. If the frequency of clock pulse from 32KOUT (CLKOUT) pin should be accurate, change the 12.5pF crystal to a 6pF crystal.

(3) If following 3 conditions are completed, actual clock adjustment value could be different from target adjustment value that set by oscillator adjustment function.

1. Using oscillator adjustment function

2. Access to RTC at random, or synchronized with external clock that has no relation to RTC, or synchronized with periodic interrupt in pulse mode.

3. Access to RTC more than 2 times per each second on average.

For more details, please contact to Ricoh.