ULTRA SMALL PACKAGE VOLTAGE REGULATOR

NO.EA-048-111020

OUTLINE

The Rx5RW Series are CMOS-based voltage regulator ICs with high accuracy output voltage and ultra-low supply current developed. Each of these ICs consists of a driver transistor, a voltage reference unit, an error amplifier, resistors for setting output voltage and a current limit circuit.

The output voltage of these ICs is fixed with high accuracy.

Even if V_{OUT} is shorted to GND, the included current limit circuit protects the ICs from the destruction. Furthermore, Rx5RWxxA/B have a chip enable function, so that the supply current on standby can be minimized.

Since the packages for these ICs are SC-82AB and SON1612-6, high density mounting of the ICs on boards is possible.

FEATURES

- Supply Current Typ. 1.5 μ A
(except pull-up/pull-down current for \overline{CE} /CE pin)
- Standby Current Typ. 0.1 μ A (applied to A/B version)
- Dropout Voltage Typ. 40mV ($I_{OUT}=1$ mA, Rx5RW30A/B/C)
- Temperature-Drift Coefficient of Output Voltage Typ. ± 100 ppm/ $^{\circ}$ C
- Line Regulation Typ. 0.05%/V
- Input Voltage Range Max. 8.0V
- Output Voltage Range 1.5V to 6.0V (0.1V steps)
- Output Voltage Accuracy $\pm 2.0\%$
- Packages SC-82AB, SON1612-6
- Built-in Current Limit Circuits

APPLICATIONS

- Power source for battery-powered equipment.
- Power source for cameras, VCRs, camcorders, hand-held audio instruments and hand-held communication equipment.
- Precision voltage references.

BLOCK DIAGRAMS

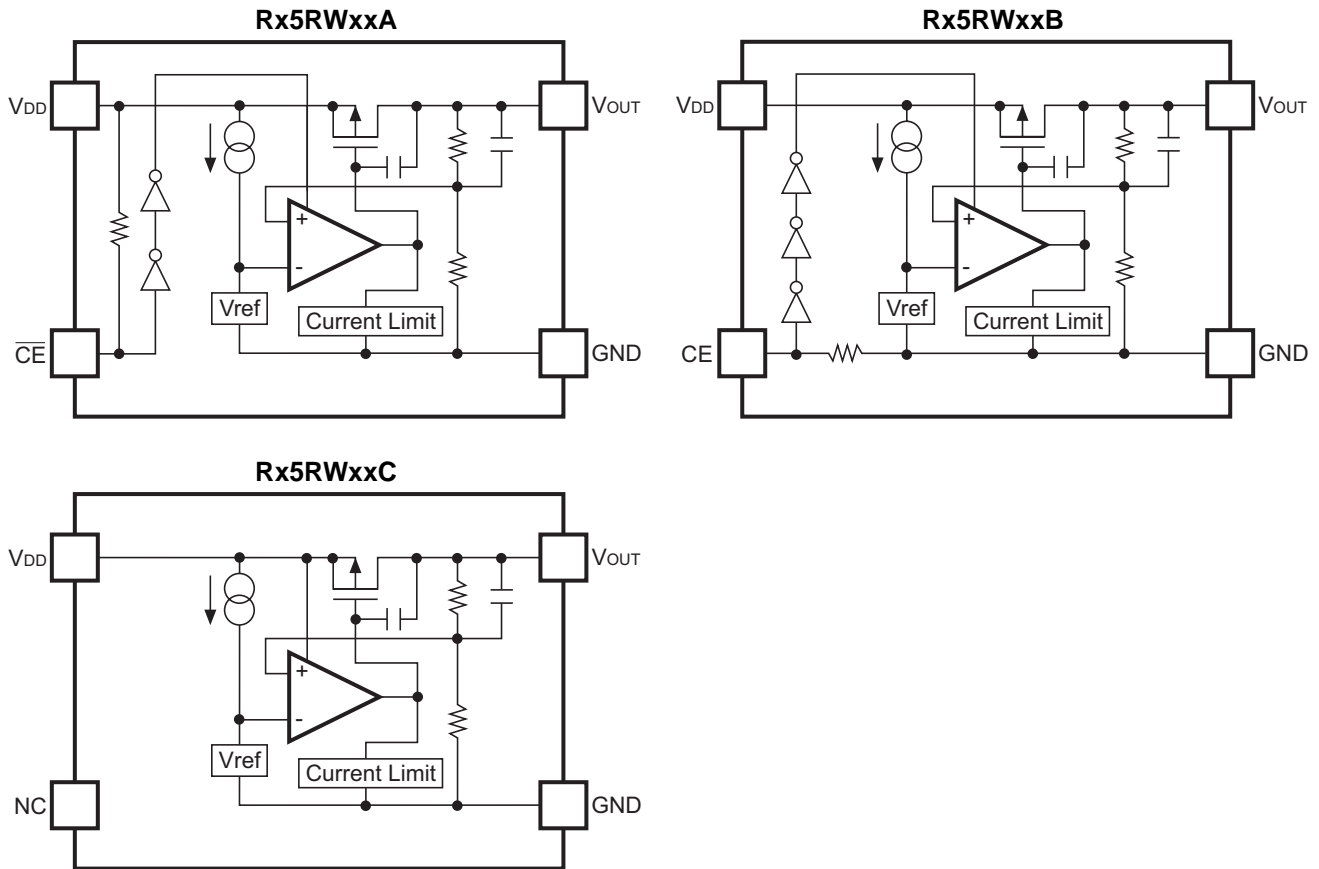

SELECTION GUIDE

The output voltage, chip enable polarity, and package, etc. for the ICs can be selected at the user's request.

Product Name	Package	Quantity per Reel	Pb Free	Halogen Free
RD5RWxx*A-TR-FE	SON1612-6	4,000 pcs	Yes	Yes
RQ5RWxx*A-TR-FE	SC-82AB	3,000 pcs	Yes	Yes

xx: The output voltage can be designated in the range from 1.5V(15) to 6.0V(60) in 0.1V steps.

* : CE pin polarity are options as follows.

- (A) "L" active
- (B) "H" active
- (C) without chip enable

PIN CONFIGURATION

● SC-82AB

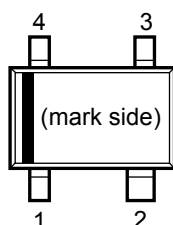

● SON1612-6

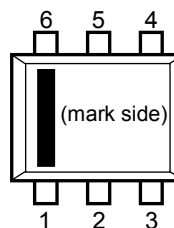

PIN DESCRIPTION

● SC-82AB

Pin No	Symbol	Pin Description
1	GND	Ground Pin
2	V _{DD}	Input Pin
3	V _{OUT}	Output Pin
4	$\overline{\text{CE}}$ or CE or NC	Chip Enable Pin ("L" active/"H" active) or No Connection

● SON1612-6

Pin No	Symbol	Pin Description
1	$\overline{\text{CE}}$ or CE or NC	Chip Enable Pin ("L" active/"H" active) or No Connection
2	V _{DD}	Input Pin
3	V _{OUT}	Output Pin
4	NC	No Connection
5	V _{DD}	Input Pin
6	GND	Ground Pin

ABSOLUTE MAXIMUM RATINGS

Symbol	Item	Rating	Unit
V_{IN}	Input Voltage	9.0	V
V_{CE}	Input Voltage for \overline{CE} /CE Pin (applied to A/B version)	-0.3 to $V_{IN} + 0.3$	V
V_{OUT}	Output Voltage	-0.3 to $V_{IN} + 0.3$	V
I_{OUT}	Output Current	150	mA
P_D	Power Dissipation (SC-82AB) *	380	mW
	Power Dissipation (SON1612-6) *	500	
T_{opt}	Operating Temperature	-40 to +85	°C
T_{stg}	Storage Temperature	-55 to +125	°C

*) For Power Dissipation, please refer to PACKAGE INFORMATION.

ABSOLUTE MAXIMUM RATINGS

Electronic and mechanical stress momentarily exceeded absolute maximum ratings may cause the permanent damages and may degrade the life time and safety for both device and system using the device in the field.

The functional operation at or over these absolute maximum ratings is not assured.

ELECTRICAL CHARACTERISTICS

• Rx5RW30A

T_{opt}=25°C

Symbol	Item	Conditions	Min.	Typ.	Max.	Unit
V _{OUT}	Output Voltage	V _{IN} =5.0V 10μA≤I _{OUT} ≤10mA	2.940	3.000	3.060	V
I _{OUT}	Output Current	V _{IN} =5.0V	50			mA
ΔV _{OUT} /ΔI _{OUT}	Load Regulation	V _{IN} =5.0V, 1mA≤I _{OUT} ≤50mA		40	60	mV
V _{DIF}	Dropout Voltage	I _{OUT} =1mA		40	60	mV
I _{SS}	Supply Current	V _{IN} =5.0V		1.5	3.0	μA
I _{standby}	Standby Current	V _{IN} =5.0V, V _{CE} =5.0V		0.1	1.0	μA
ΔV _{OUT} /ΔV _{IN}	Line Regulation	I _{OUT} =1mA V _{OUT} +0.5V≤V _{IN} ≤8V	0	0.05	0.20	%/V
V _{IN}	Input Voltage				8.0	V
ΔV _{OUT} /ΔT _{opt}	Output Voltage Temperature Coefficient	I _{OUT} =10mA -40°C≤T _{opt} ≤85°C		±100		ppm/ °C
I _{SC}	Short Current Limit			40		mA
R _{PU}	Pull up resistance for CE pin		1.5	4.0	12.0	MΩ
V _{CEH}	\overline{CE} Input Voltage "H"		1.5			V
V _{CEL}	\overline{CE} Input Voltage "L"				0.25	V

• Rx5RW30B

T_{opt}=25°C

Symbol	Item	Conditions	Min.	Typ.	Max.	Unit
V _{OUT}	Output Voltage	V _{IN} =5.0V 10μA≤I _{OUT} ≤10mA	2.940	3.000	3.060	V
I _{OUT}	Output Current	V _{IN} =5.0V	50			mA
ΔV _{OUT} /ΔI _{OUT}	Load Regulation	V _{IN} =5.0V 1mA≤I _{OUT} ≤50mA		40	60	mV
V _{DIF}	Dropout Voltage	I _{OUT} =1mA		40	60	mV
I _{SS}	Supply Current	V _{IN} =5.0V		1.5	3.0	μA
I _{standby}	Standby Current	V _{IN} =5.0V, V _{CE} =GND		0.1	1.0	μA
ΔV _{OUT} /ΔV _{IN}	Line Regulation	I _{OUT} =1mA V _{OUT} +0.5V≤V _{IN} ≤8V	0	0.05	0.20	%/V
V _{IN}	Input Voltage				8.0	V
ΔV _{OUT} /ΔT _{opt}	Output Voltage Temperature Coefficient	I _{OUT} =1mA -40°C≤T _{opt} ≤85°C		±100		ppm/ °C
I _{SC}	Short Current Limit			40		mA
R _{PD}	Pull down resistance for CE pin		1.5	4.0	12.0	MΩ
V _{CEH}	CE Input Voltage "H"		1.5			V
V _{CEL}	CE Input Voltage "L"				0.25	V

Rx5RW

• Rx5RW30CT_{opt}=25°C

Symbol	Item	Conditions	Min.	Tyo.	Max.	Unit
V _{OUT}	Output Voltage	V _{IN} =5.0V 10μA≤I _{OUT} ≤10mA	2.940	3.000	3.060	V
I _{OUT}	Output Current	V _{IN} =5.0V	50			mA
ΔV _{OUT} /ΔI _{OUT}	Load Regulation	V _{IN} =5.0V 1mA≤I _{OUT} ≤50mA		40	60	mV
V _{DIF}	Dropout Voltage	I _{OUT} =1mA		40	60	mV
I _{SS}	Supply Current	V _{IN} =5.0V		1.5	3.0	μA
ΔV _{OUT} /ΔV _{IN}	Line Regulation	I _{OUT} =1mA 3.5V≤V _{IN} ≤8.0V	0	0.05	0.20	%/V
V _{IN}	Input Voltage				8.0	V
ΔV _{OUT} /ΔT _{opt}	Output Voltage Temperature Coefficient	I _{OUT} =10mA -40°C≤T _{opt} ≤85°C		±100		ppm/ °C
I _{SC}	Short Current Limit			40		mA

RECOMMENDED OPERATING CONDITIONS (ELECTRICAL CHARACTERISTICS)

All of electronic equipment should be designed that the mounted semiconductor devices operate within the recommended operating conditions. The semiconductor devices cannot operate normally over the recommended operating conditions, even if when they are used over such conditions by momentary electronic noise or surge. And the semiconductor devices may receive serious damage when they continue to operate over the recommended operating conditions.

ELECTRICAL CHARACTERISTICS BY OUTPUT VOLTAGE

Topt=25°C

Part Number	Output Voltage				Output Current		Load Regulation			Dropout Voltage		
	Conditions	V _{OUT} (V)			I _{OUT} (mA)		ΔV _{OUT} /ΔI _{OUT} (mV)			V _{DIF} (mV)		
		Min.	Typ.	Max.	Conditions	Min.	Conditions	Typ.	Max.	Conditions	Typ.	Max.
Rx5RW15	V _{IN} -V _{OUT} =2.0V 10μA≤I _{OUT} ≤10mA	1.470	1.500	1.530	V _{IN} -V _{OUT} =2.0V	35	V _{IN} -V _{OUT} =2.0V 1mA≤I _{OUT} ≤35mA	30	45	I _{OUT} =1mA	120	200
Rx5RW16		1.568	1.600	1.632							90	135
Rx5RW17		1.666	1.700	1.734							60	90
Rx5RW18		1.764	1.800	1.836								
Rx5RW19		1.862	1.900	1.938								
Rx5RW20		1.960	2.000	2.040								
Rx5RW21		2.058	2.100	2.142								
Rx5RW22		2.156	2.200	2.244								
Rx5RW23		2.254	2.300	2.346								
Rx5RW24		2.352	2.400	2.448								
Rx5RW25		2.450	2.500	2.550								
Rx5RW26		2.548	2.600	2.652								
Rx5RW27		2.646	2.700	2.754								
Rx5RW28		2.744	2.800	2.856								
Rx5RW29		2.842	2.900	2.958								
Rx5RW30		2.940	3.000	3.060								
Rx5RW31		3.038	3.100	3.162		50	V _{IN} -V _{OUT} =2.0V 1mA≤I _{OUT} ≤50mA	40	60			
Rx5RW32		3.136	3.200	3.264								
Rx5RW33		3.234	3.300	3.366								
Rx5RW34		3.332	3.400	3.468								
Rx5RW35		3.430	3.500	3.570								
Rx5RW36		3.528	3.600	3.672								
Rx5RW37		3.626	3.700	3.774								
Rx5RW38		3.724	3.800	3.876								
Rx5RW39		3.822	3.900	3.978								
Rx5RW40		3.920	4.000	4.080								
Rx5RW41		4.018	4.100	4.182		65	V _{IN} -V _{OUT} =2.0V 1mA≤I _{OUT} ≤65mA	50	70			
Rx5RW42		4.116	4.200	4.284								
Rx5RW43		4.214	4.300	4.386								
Rx5RW44		4.312	4.400	4.488								
Rx5RW45		4.410	4.500	4.590								
Rx5RW46		4.508	4.600	4.692								
Rx5RW47		4.606	4.700	4.794								
Rx5RW48		4.704	4.800	4.896								
Rx5RW49		4.802	4.900	4.998								
Rx5RW50		4.900	5.000	5.100								
Rx5RW51		4.998	5.100	5.202								
Rx5RW52		5.096	5.200	5.304								
Rx5RW53		5.194	5.300	5.406								
Rx5RW54		5.292	5.400	5.508								
Rx5RW55	5.390	5.500	5.610									
Rx5RW56	5.488	5.600	5.712									
Rx5RW57	5.586	5.700	5.814									
Rx5RW58	5.684	5.800	5.916									
Rx5RW59	5.782	5.900	6.018									
Rx5RW60	5.880	6.000	6.120	80	V _{IN} -V _{OUT} =2.0V 1mA≤I _{OUT} ≤80mA	60	90					

ELECTRICAL CHARACTERISTICS BY OUTPUT VOLTAGE

(common characteristics)

T_{opt}=25°C

Symbol	Item	Conditions	Min.	Typ.	Max.	Unit
I _{SS}	Supply Current	V _{IN} =Set V _{OUT} +2.0		1.5	3.0	μA
I _{standby}	Standby Current	V _{IN} =Set V _{OUT} +2.0V V _{CE} =V _{IN} (Rx5RWxxA), V _{CE} =GND (Rx5RWxxB)		0.1	1.0	μA
ΔV _{OUT} /ΔV _{IN}	Line Regulation	I _{OUT} =1mA Set V _{OUT} +0.5V≤V _{IN} ≤8V	0	0.05	0.20	%/V
V _{IN}	Input Voltage				8.0	V
ΔV _{OUT} /ΔT _{opt}	Output Voltage Temperature Coefficient	I _{OUT} =10mA -40°C≤T _{opt} ≤85°C		±100		ppm/ °C
I _{SC}	Short Current Limit			40		mA
R _{PU} /R _{PD}	$\overline{\text{CE}}$ Pull-up / CE Pull-down Resistance	applied to A/B version	1.5	4.0	12.0	MΩ
V _{CEH}	$\overline{\text{CE}}$ /CE Input Voltage "H"	applied to A/B version	1.5			V
V _{CEL}	$\overline{\text{CE}}$ /CE Input Voltage "L"	applied to A/B version			0.25	V

RECOMMENDED OPERATING CONDITIONS (ELECTRICAL CHARACTERISTICS)

All of electronic equipment should be designed that the mounted semiconductor devices operate within the recommended operating conditions. The semiconductor devices cannot operate normally over the recommended operating conditions, even if when they are used over such conditions by momentary electronic noise or surge. And the semiconductor devices may receive serious damage when they continue to operate over the recommended operating conditions.

OPERATION

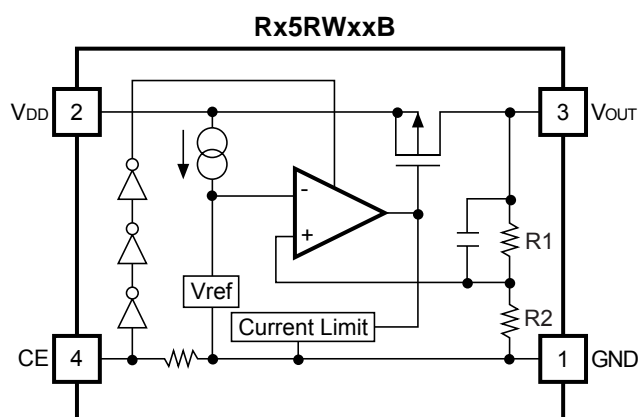

In these ICs, output voltage V_{OUT} is detected by Feedback Registers R1, R2, and the detected output voltage is compared with a reference voltage by the error amplifier, so that a constant voltage is output.

A current limit circuit working for short protect, and a chip enable circuit are included.

TEST CIRCUITS

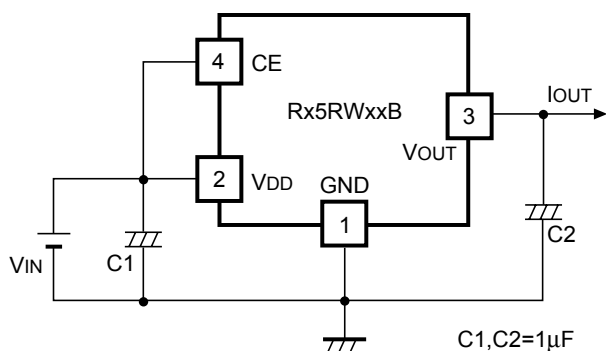

Standard Test Circuit

C1,C2=1 μ F

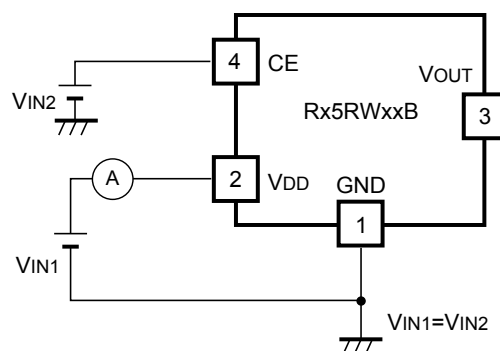

Supply Current Test Circuit

VIN1=VIN2

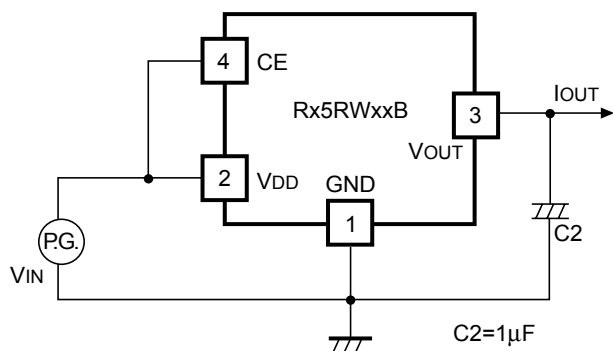

Ripple Rejection and Line
Transient Response Test Circuit

C2=1 μ F

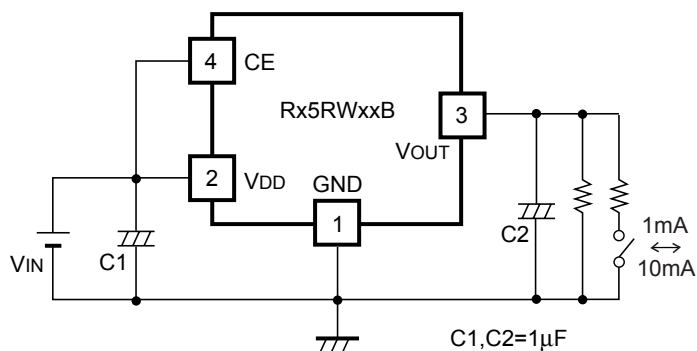

Load Transient Response Test Circuit

C1,C2=1 μ F

TYPICAL APPLICATION

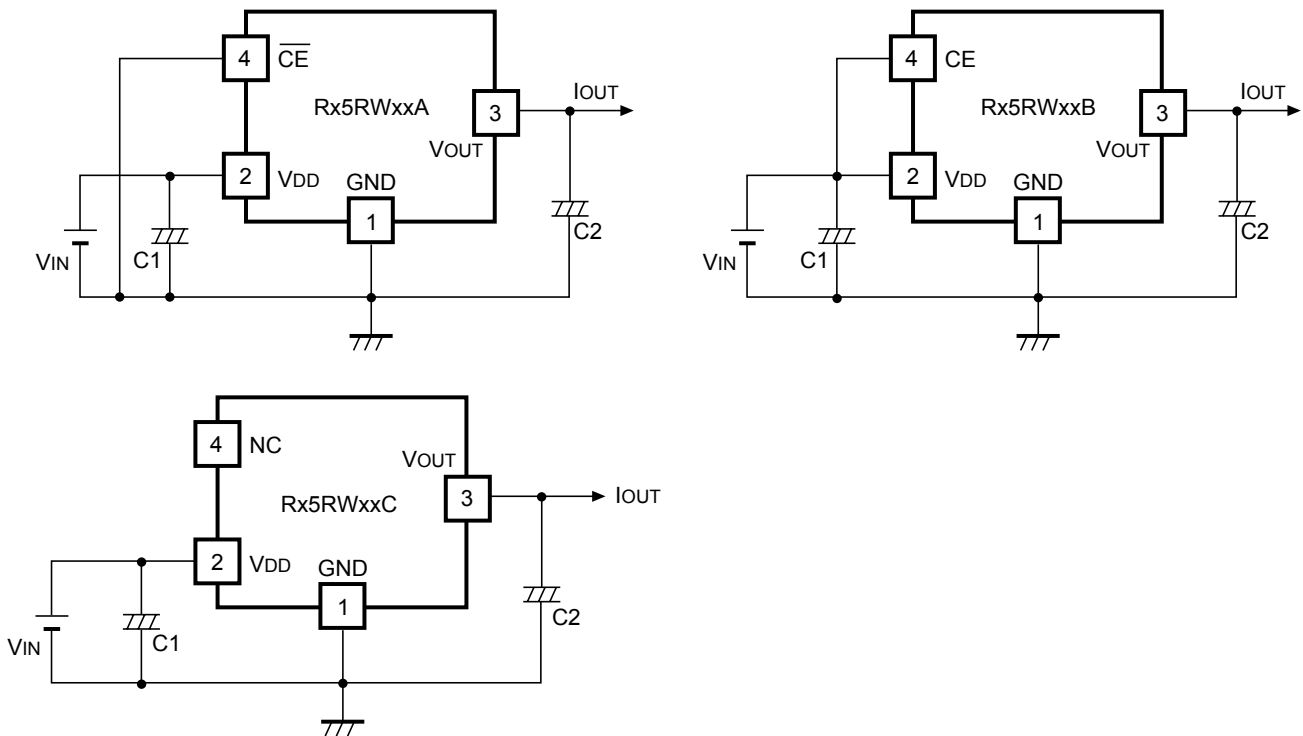

In Rx5RW Series, a constant voltage can be obtained without using capacitors, C1 and C2. However, when the wire connected V_{IN} is long, use capacitor C1. Output noise can be reduced with using capacitor 2.

Insert capacitors C1 and C2 with the capacitance of $0.1\mu\text{F}$ to $2\mu\text{F}$ between input/output pins and GND pin with minimum wiring.

TYPICAL CHARACTERISTICS

1) Output Voltage vs. Output Current

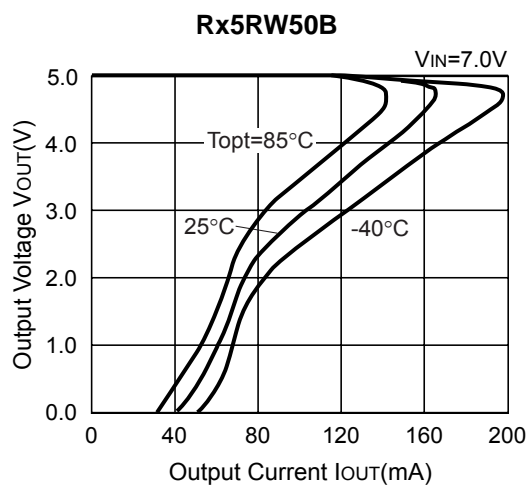
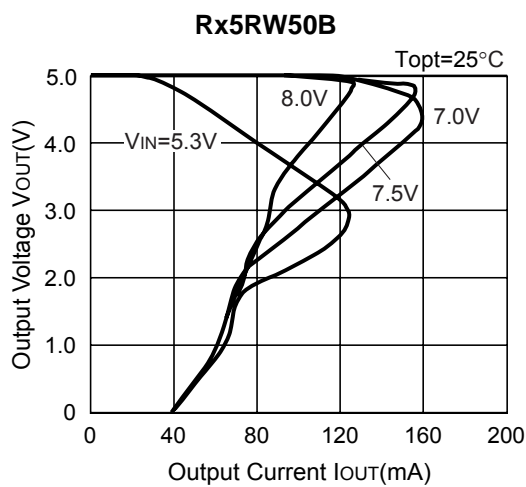
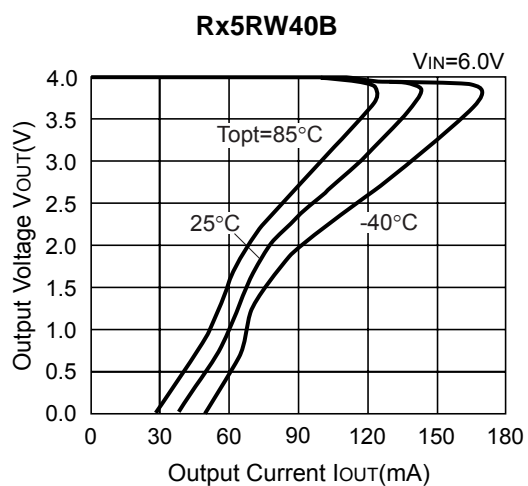
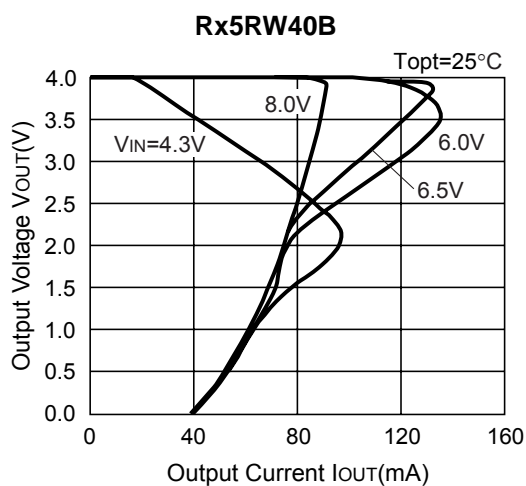
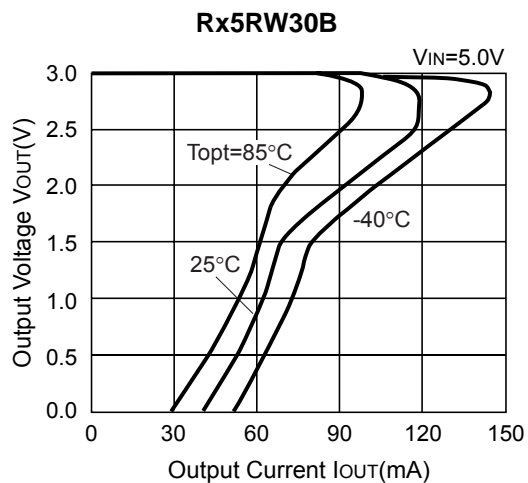
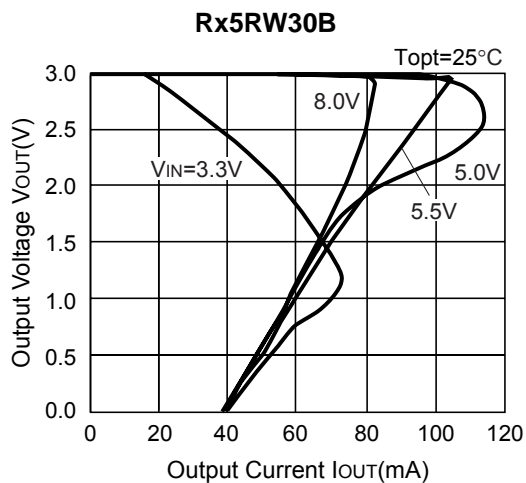

2) Output Voltage vs. Input Voltage

Rx5RW30B

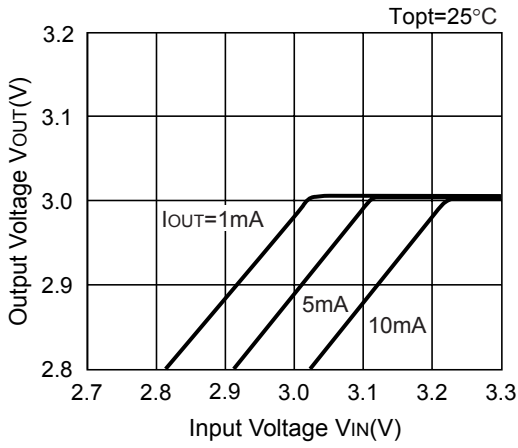

Rx5RW30B

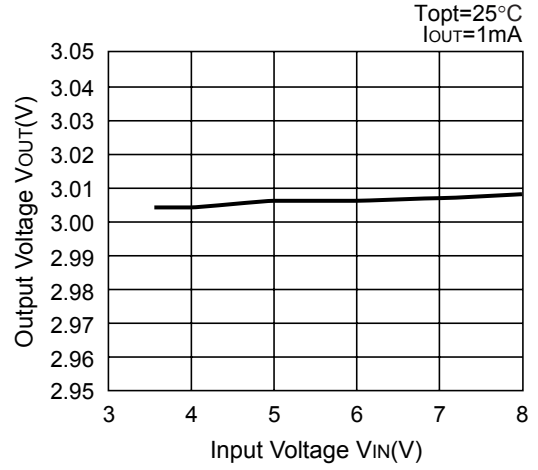

Rx5RW40B

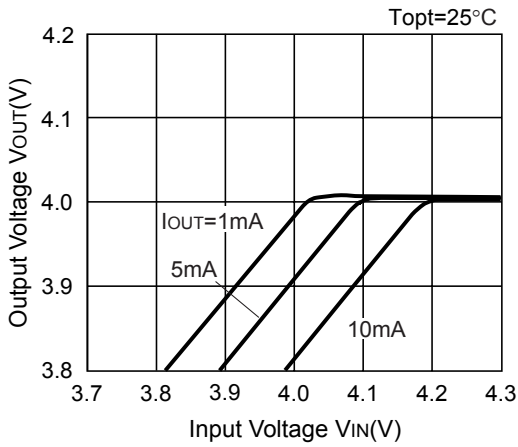

Rx5RW40B

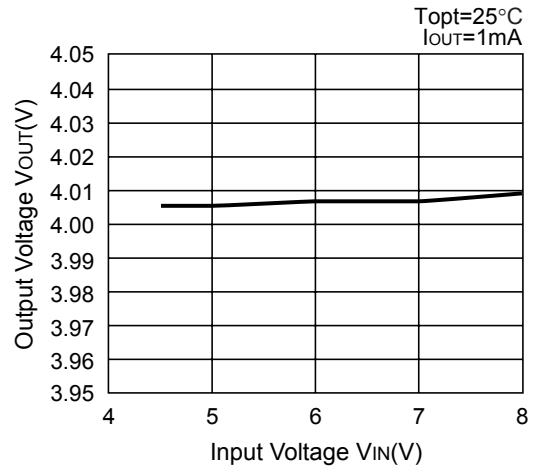

Rx5RW50B

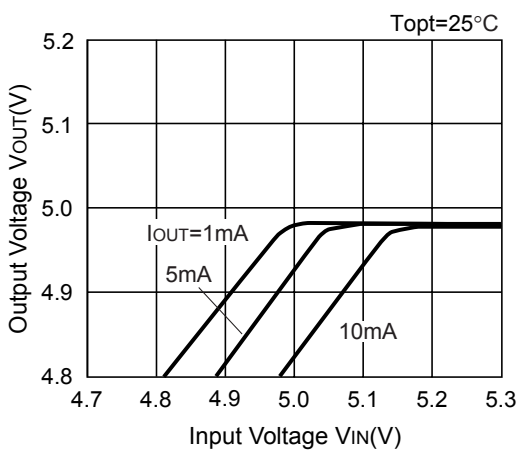

Rx5RW50B

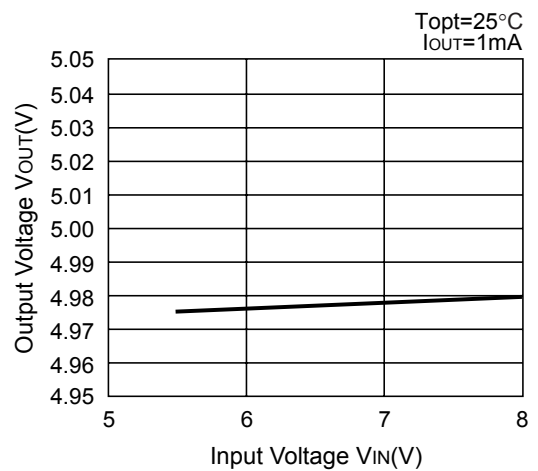

3) Dropout Voltage vs. Output Current

Rx5RW30B

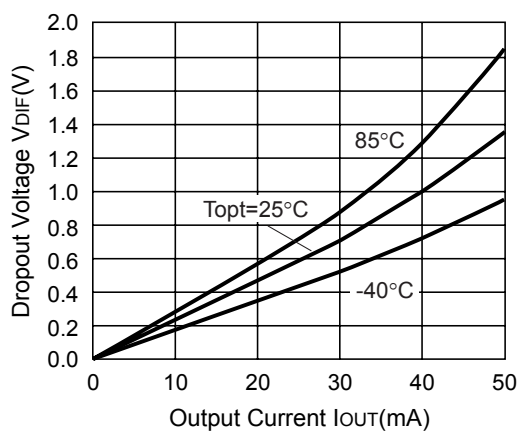

Rx5RW40B

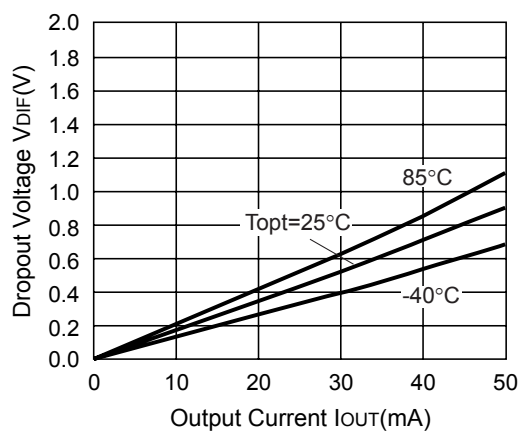

Rx5RW50B

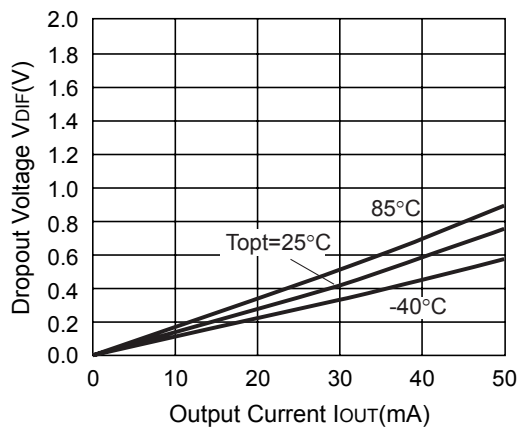

4) Output Voltage vs. Temperature

Rx5RW30B

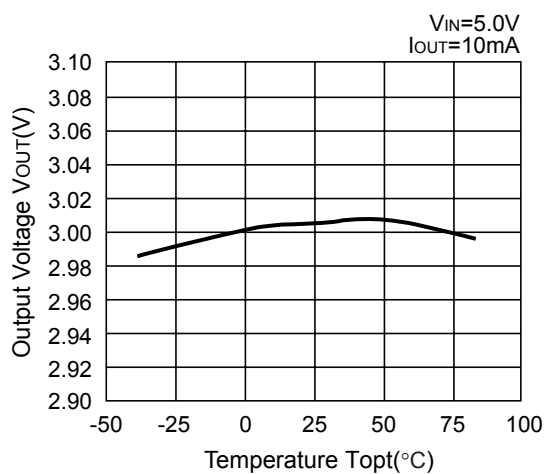

Rx5RW40B

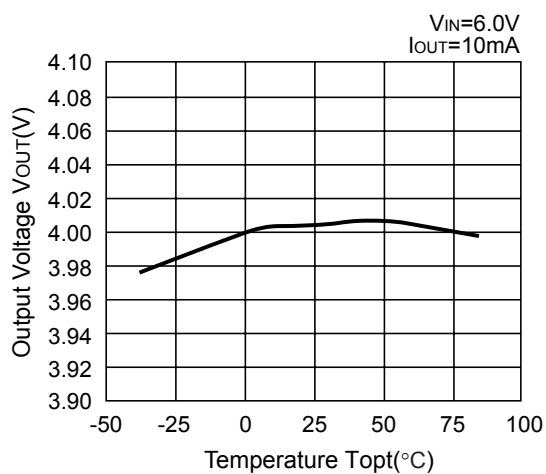

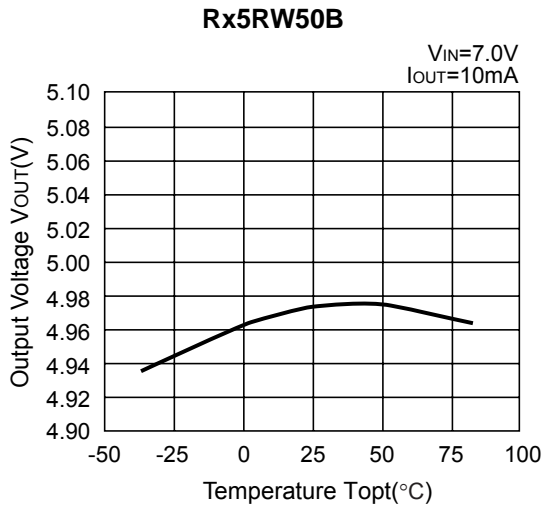

5) Supply Current vs. Input Voltage

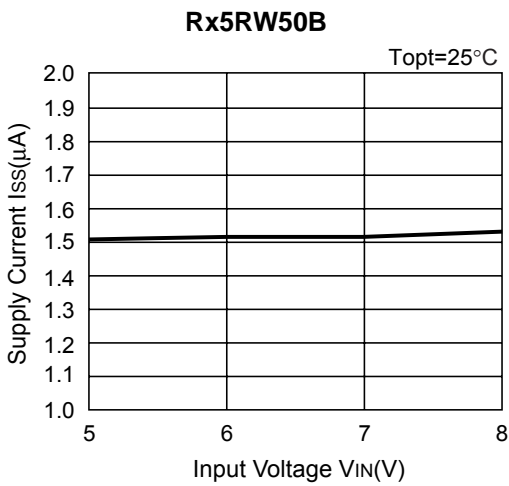
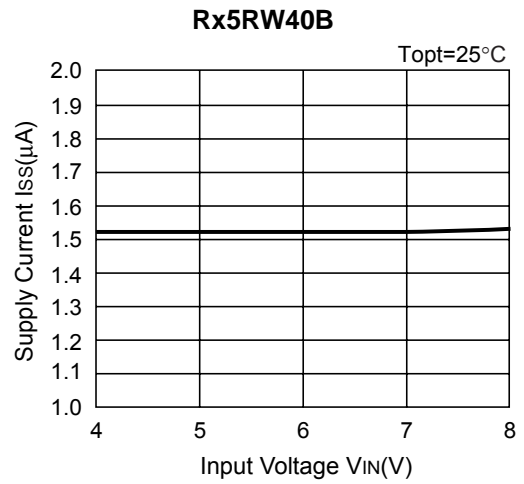
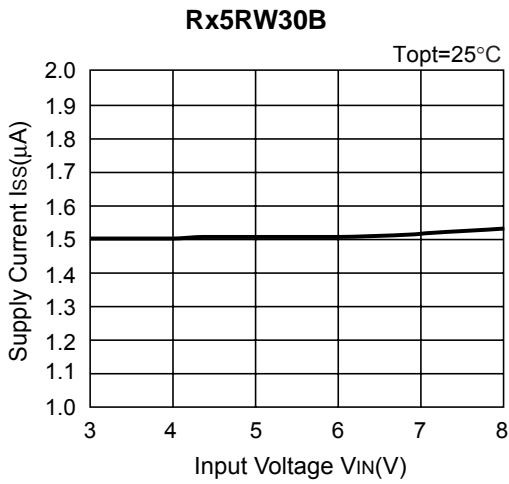

6) Supply Current vs. Temperature

Rx5RW30B

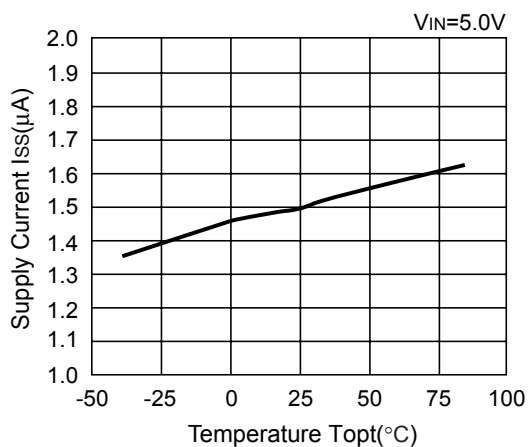

Rx5RW40B

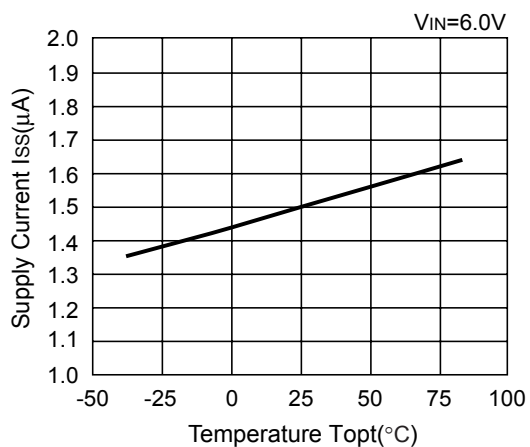

Rx5RW50B

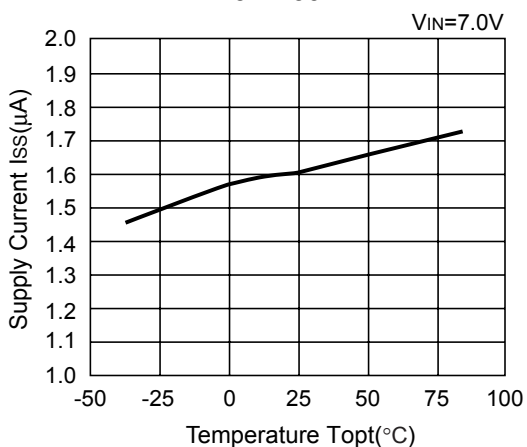

7) Dropout Voltage vs. Set Output Voltage

Rx5RWxxB

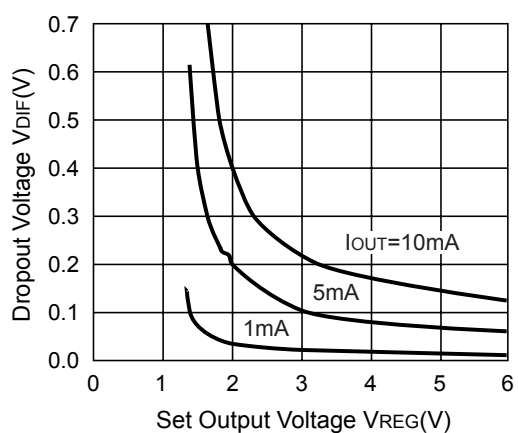

8) Line Transient Response

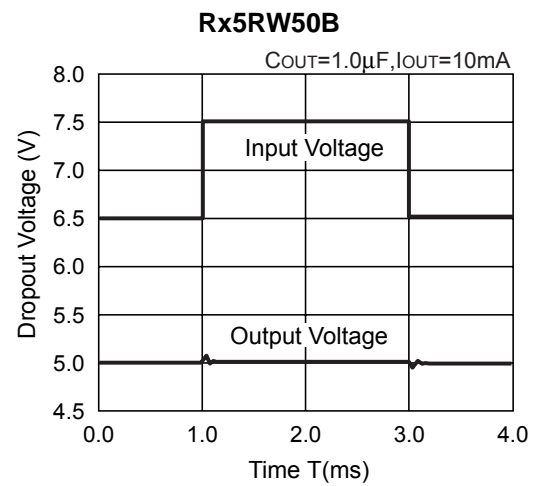
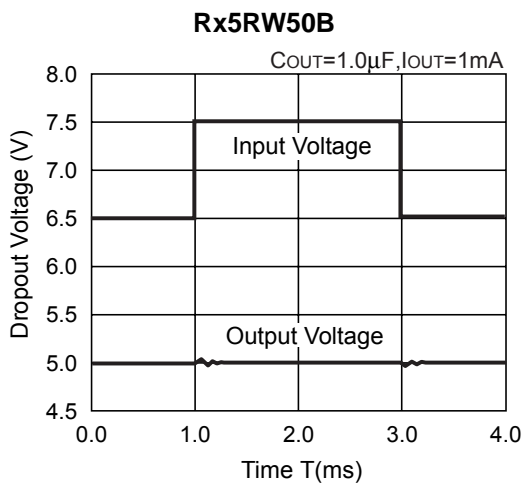
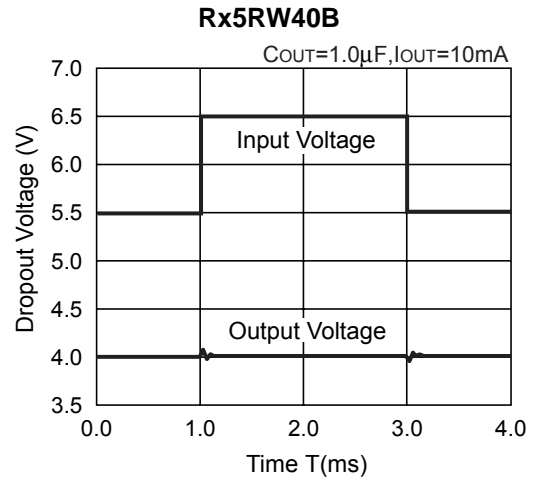
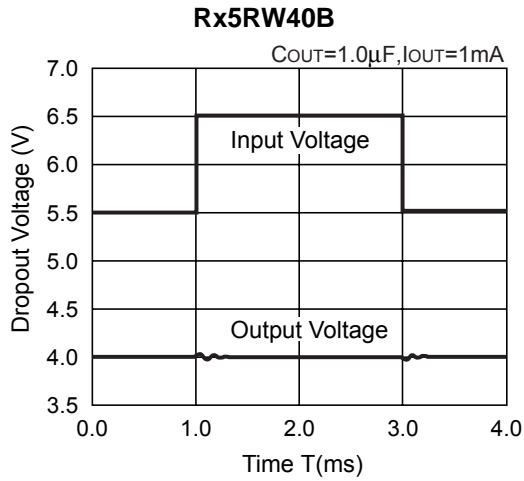
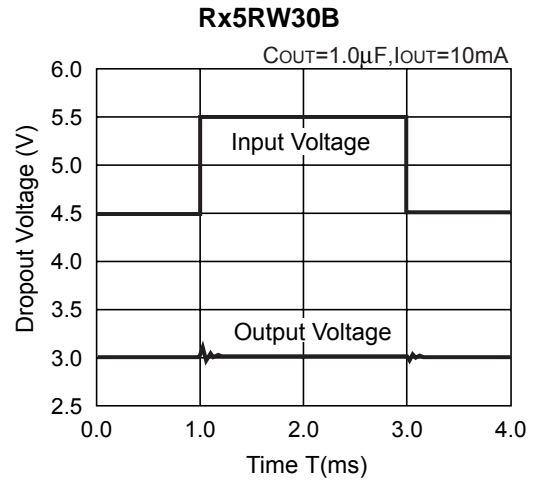
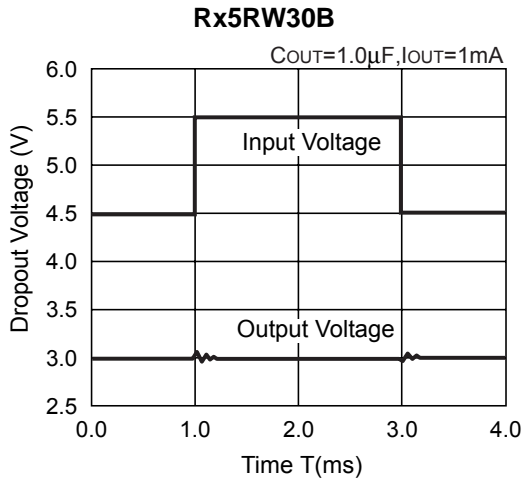

9) Load Transient Response

Rx5RW30B

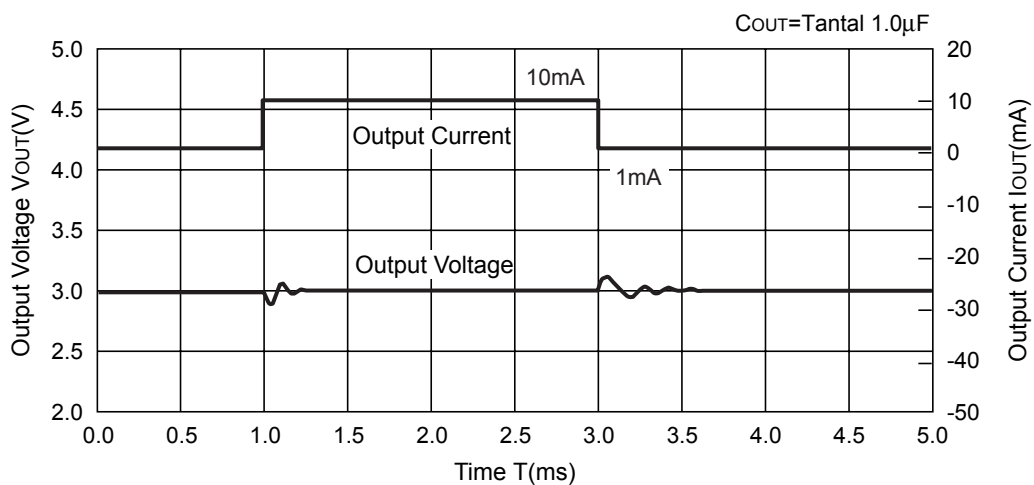

Rx5RW40B

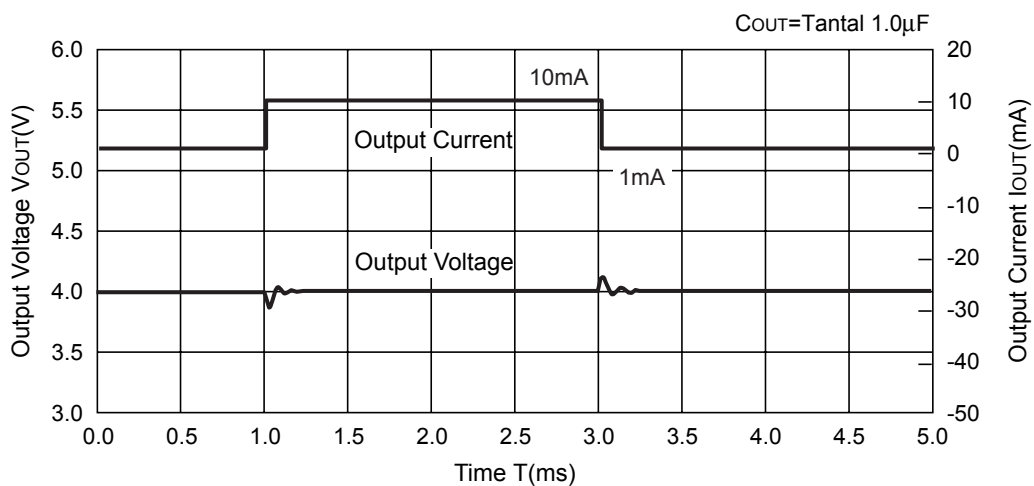

Rx5RW50B

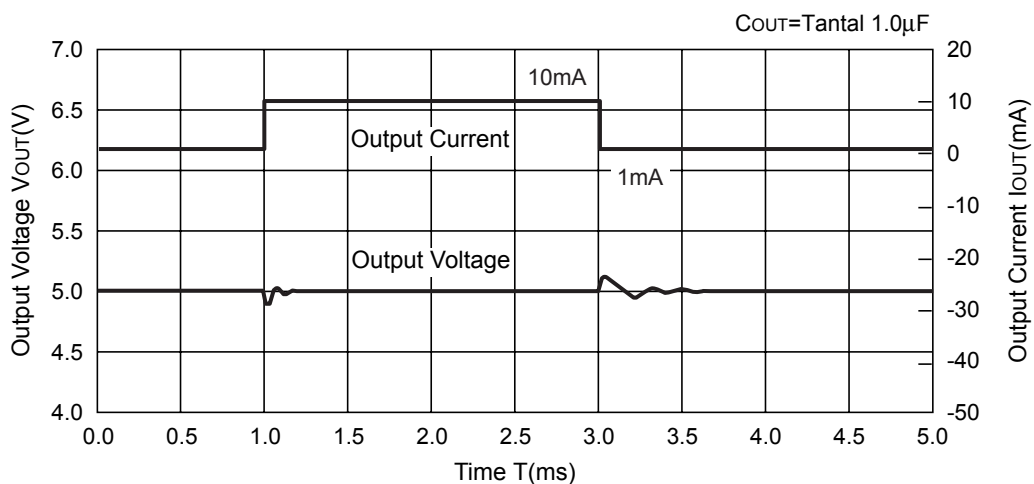

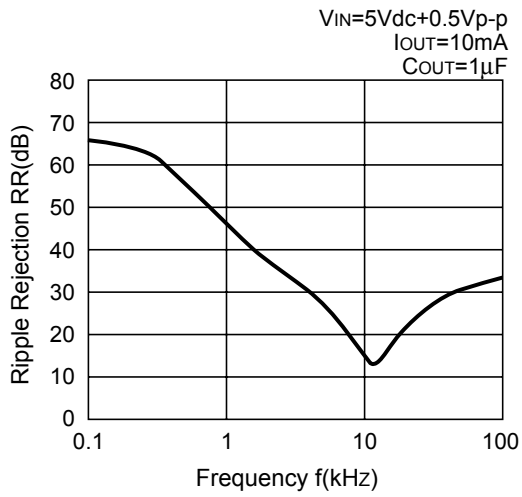
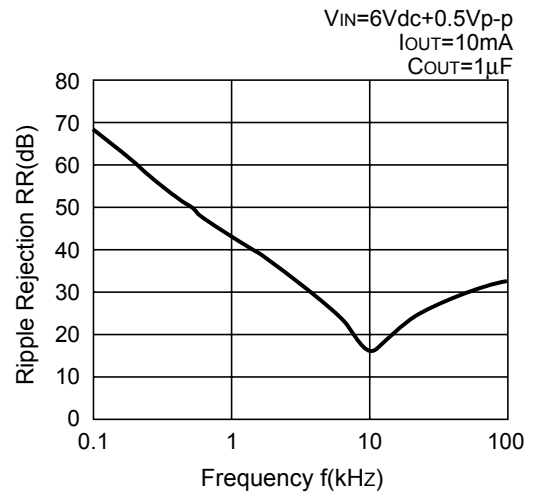
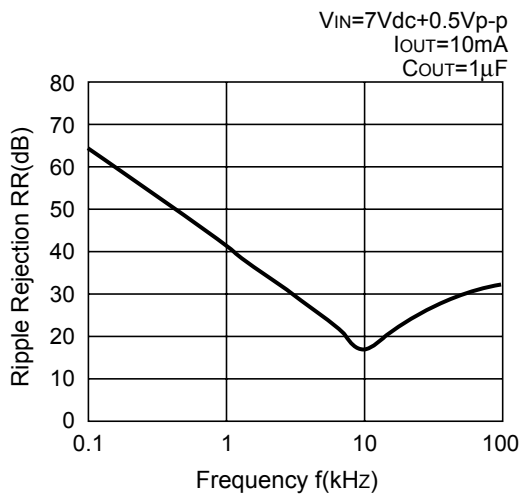
10) Ripple Rejection**Rx5RW30B****Rx5RW40B****Rx5RW50B**



1. The products and the product specifications described in this document are subject to change or discontinuation of production without notice for reasons such as improvement. Therefore, before deciding to use the products, please refer to Ricoh sales representatives for the latest information thereon.
2. The materials in this document may not be copied or otherwise reproduced in whole or in part without prior written consent of Ricoh.
3. Please be sure to take any necessary formalities under relevant laws or regulations before exporting or otherwise taking out of your country the products or the technical information described herein.
4. The technical information described in this document shows typical characteristics of and example application circuits for the products. The release of such information is not to be construed as a warranty of or a grant of license under Ricoh's or any third party's intellectual property rights or any other rights.
5. The products listed in this document are intended and designed for use as general electronic components in standard applications (office equipment, telecommunication equipment, measuring instruments, consumer electronic products, amusement equipment etc.). Those customers intending to use a product in an application requiring extreme quality and reliability, for example, in a highly specific application where the failure or misoperation of the product could result in human injury or death (aircraft, spacevehicle, nuclear reactor control system, traffic control system, automotive and transportation equipment, combustion equipment, safety devices, life support system etc.) should first contact us.
6. We are making our continuous effort to improve the quality and reliability of our products, but semiconductor products are likely to fail with certain probability. In order to prevent any injury to persons or damages to property resulting from such failure, customers should be careful enough to incorporate safety measures in their design, such as redundancy feature, firecontainment feature and fail-safe feature. We do not assume any liability or responsibility for any loss or damage arising from misuse or inappropriate use of the products.
7. Anti-radiation design is not implemented in the products described in this document.
8. Please contact Ricoh sales representatives should you have any questions or comments concerning the products or the technical information.

RICOH COMPANY., LTD. Electronic Devices Company



■ Ricoh presented with the Japan Management Quality Award for 1999.
Ricoh continually strives to promote customer satisfaction, and shares the achievements of its management quality improvement program with people and society.



■ Ricoh awarded ISO 14001 certification.
The Ricoh Group was awarded ISO 14001 certification, which is an international standard for environmental management systems, at both its domestic and overseas production facilities. Our current aim is to obtain ISO 14001 certification for all of our business offices.

<http://www.ricoh.com/LSI/>

RICOH COMPANY, LTD. Electronic Devices Company

● Higashi-Shinagawa Office (International Sales)
3-32-3, Higashi-Shinagawa, Shinagawa-ku, Tokyo 140-8655, Japan
Phone: +81-3-5479-2857 Fax: +81-3-5479-0502

RICOH EUROPE (NETHERLANDS) B.V.

● Semiconductor Support Centre
Prof. W.H.Keesomlaan 1, 1183 DL Amstelveen, The Netherlands
P.O.Box 114, 1180 AC Amstelveen
Phone: +31-20-5474-309 Fax: +31-20-5474-791

RICOH ELECTRONIC DEVICES KOREA Co., Ltd.

11 floor, Haesung 1 building, 942, Daechidong, Gangnamgu, Seoul, Korea
Phone: +82-2-2135-5700 Fax: +82-2-2135-5705

RICOH ELECTRONIC DEVICES SHANGHAI Co., Ltd.

Room403, No.2 Building, 690#Bi Bo Road, Pu Dong New district, Shanghai 201203,
People's Republic of China
Phone: +86-21-5027-3200 Fax: +86-21-5027-3299

RICOH COMPANY, LTD. Electronic Devices Company

● Taipei office
Room109, 10F-1, No.51, Hengyang Rd., Taipei City, Taiwan (R.O.C.)
Phone: +886-2-2313-1621/1622 Fax: +886-2-2313-1623



Ricoh completed the organization of the Lead-free production for all of our products. After Apr. 1, 2006, we will ship out the lead free products only. Thus, all products that will be shipped from now on comply with RoHS Directive.