

---

## 0.8%ACCURACY 0.7V OUTPUT 400mA LDO REGULATOR

---

NO.EA-180-111020

### OUTLINE

The RP106x Series are low voltage 400mA voltage regulator. These ICs had been further improved of low-voltage capability compared with previous low-voltage product.

The input voltage is as low as Min. 1.0V and the output voltage can be set from 0.7V. The output voltage accuracy has been improved to  $\pm 0.8\%$  and due to a built-in transistor with low on-resistance of  $0.55\Omega$  (at  $V_{OUT}=1.5V$ ).

Each of these ICs consists of a voltage reference unit, an error amplifier, a resistor-net for voltage setting, and a current limit circuits for over-current for the destruction prevention by the over-current.

The CE pin can switch the regulator to standby mode. In addition to SOT-23-5 and SC-88A packages, a 0.69mm square WLCSP-4-P5 package and a 1.2mm square DFN(PLP)1212-6 are also available.

### FEATURES

- Supply Current ..... Typ.  $48\mu A$
- Standby Current ..... Typ.  $0.1\mu A$
- Ripple Rejection ..... Typ. 60dB ( $f=10kHz$ )
- Input Voltage Range ..... 1.0V to 3.6V
- Output Voltage Range ..... 0.7V to 1.8V (0.1V steps)  
(For other voltages, please refer to MARK INFORMATION.)
- Output Voltage Accuracy .....  $\pm 0.8\%$  ( $V_{OUT}\geq 1.0V$ ,  $T_{opt}=25^{\circ}C$ )
- Temperature-Drift Coefficient of Output Voltage ... Typ.  $\pm 60ppm/^{\circ}C$
- Dropout Voltage ..... Typ. 0.22V ( $V_{OUT}=1.5V$ )
- Line Regulation ..... Typ. 0.10%/V
- Packages ..... WLCSP-4-P5, DFN(PLP)1212-6, SC-88A, SOT-23-5
- Built-in Fold Back Protection Circuit ..... Typ. 110mA (Current at short mode)
- Built-in Constant Slope Circuit
- Ceramic capacitors are recommended to be used with this IC .....  $1.0\mu F$  or more

### APPLICATIONS

- Power source for portable communication equipment.
- Power source for electrical appliances such as cameras, VCRs and camcorders.
- Power source for battery-powered equipment.

## BLOCK DIAGRAMS

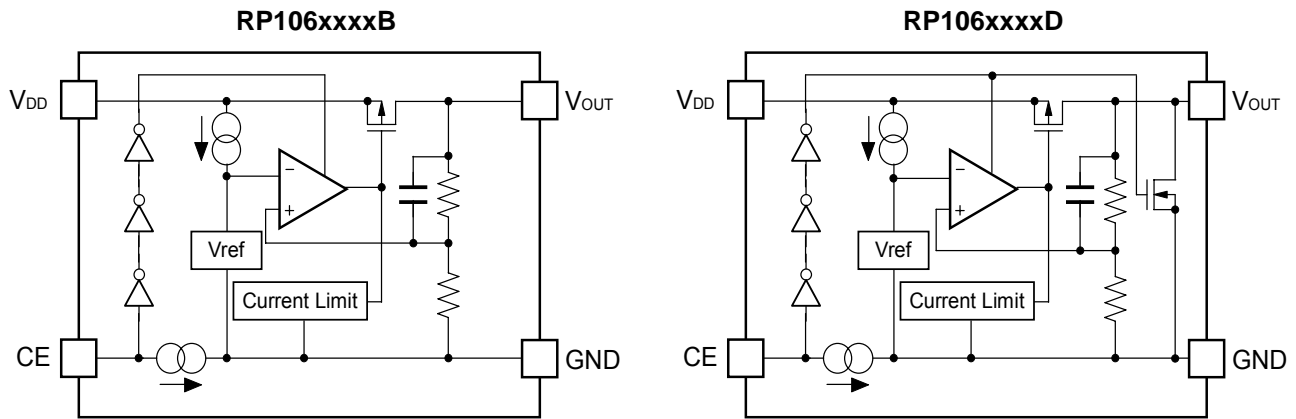

## SELECTION GUIDE

The output voltage, auto discharge function, package, and the taping type, etc. for the ICs can be selected at the user's request.

Product Name	Package	Quantity per Reel	Pb Free	Halogen Free
RP106Zxx1*-TR-F	WLCSP-4-P5	5,000 pcs	Yes	Yes
RP106Kxx1*-TR	DFN(PLP)1212-6	5,000 pcs	Yes	Yes
RP106Qxx2*-TR-FE	SC-88A	3,000 pcs	Yes	Yes
RP106Nxx1*-TR-FE	SOT-23-5	3,000 pcs	Yes	Yes

xx: The output voltage can be designated in the range from 0.7V(07) to 1.8V(18) in 0.1V steps.  
(For other voltages, please refer to MARK INFORMATIONS.)

\* : CE pin polarity and auto discharge function at off state are options as follows.  
(B) without auto discharge function at off state  
(D) with auto discharge function at off state

## PIN CONFIGURATIONS

### • WLCSP-4-P5

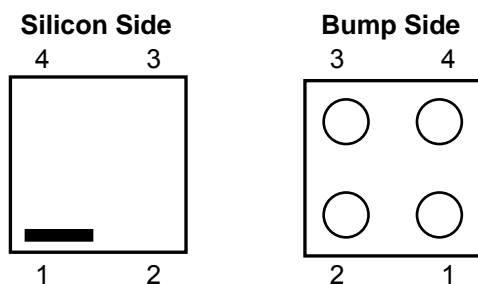

### • DFN(PLP)1212-6

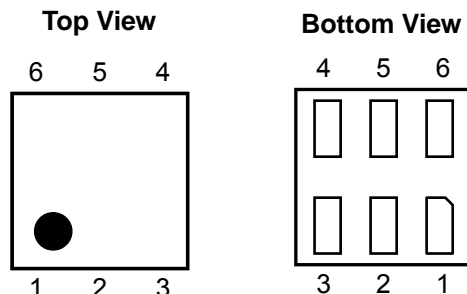

### • SC-88A

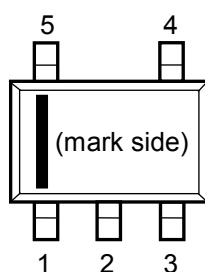

### • SOT-23-5

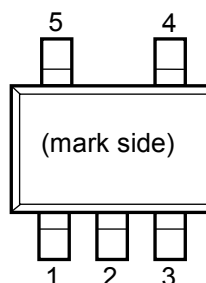

## PIN DESCRIPTIONS

### • WLCSP-4-P5

Pin No.	Symbol	Description
1	V <sub>DD</sub>	Input Pin
2	CE	Chip Enable Pin ("H" Active)
3	GND	Ground Pin
4	V <sub>OUT</sub>	Output Pin

### • DFN(PLP)1212-6

Pin No.	Symbol	Description
1	NC	No Connection
2	GND	Ground Pin
3	CE	Chip Enable Pin ("H" Active)
4	V <sub>DD</sub>	Input Pin
5	NC	No Connection
6	V <sub>OUT</sub>	Output Pin

### • SC-88A

Pin No.	Symbol	Description
1	CE	Chip Enable Pin ("H" Active)
2	NC	No Connection
3	GND	Ground Pin
4	V <sub>OUT</sub>	Output Pin
5	V <sub>DD</sub>	Input Pin

### • SOT-23-5

Pin No.	Symbol	Description
1	V <sub>DD</sub>	Input Pin
2	GND	Ground Pin
3	CE	Chip Enable Pin ("H" Active)
4	NC	No Connection
5	V <sub>OUT</sub>	Output Pin

## ABSOLUTE MAXIMUM RATINGS

Symbol	Item	Rating	Unit
$V_{IN}$	Input Voltage	4.0	V
$V_{CE}$	Input Voltage (CE Pin)	-0.3 to 4.0	V
$V_{OUT}$	Output Voltage	-0.3 to $V_{IN}+0.3$	V
$I_{OUT}$	Output Current	500	mA
$P_D$	Power Dissipation (WLCSP-4-P5)*	278	mW
	Power Dissipation (DFN(PLP)1212-6)*	400	
	Power Dissipation (SC-88A)*	380	
	Power Dissipation (SOT-23-5)*	420	
$T_{opt}$	Operating Temperature Range	-40 to 85	°C
$T_{stg}$	Storage Temperature Range	-55 to 125	°C

\*) For Power Dissipation, please refer to PACKAGE INFORMATION.

### ABSOLUTE MAXIMUM RATINGS

Electronic and mechanical stress momentarily exceeded absolute maximum ratings may cause the permanent damages and may degrade the life time and safety for both device and system using the device in the field. The functional operation at or over these absolute maximum ratings is not assured.

## ELECTRICAL CHARACTERISTICS

### • RP106x

$V_{IN} = \text{Set } V_{OUT} + 1V$ ,  $I_{OUT} = 1mA$ ,  $C_{IN} = C_{OUT} = 1\mu F$ , unless otherwise noted.

The specification in    is checked and guaranteed by design engineering at  $-40^{\circ}C \leq T_{opt} \leq 85^{\circ}C$ .

$T_{opt} = 25^{\circ}C$

Symbol	Item	Conditions	Min.	Typ.	Max.	Unit	
$V_{OUT}$	Output Voltage	$T_{opt} = 25^{\circ}C$	$V_{OUT} \geq 1.0V$	$\times 0.992$		$\times 1.008$	V
			$V_{OUT} < 1.0V$	-8		8	mV
		$-40^{\circ}C \leq T_{opt} \leq 85^{\circ}C$	$V_{OUT} \geq 1.0V$	<span style="border: 1px solid black; padding: 0 2px;">×0.983</span>		<span style="border: 1px solid black; padding: 0 2px;">×1.017</span>	V
			$V_{OUT} < 1.0V$	<span style="border: 1px solid black; padding: 0 2px;">-17</span>		<span style="border: 1px solid black; padding: 0 2px;">17</span>	mV
$I_{OUT}$	Output Current		<span style="border: 1px solid black; padding: 0 2px;">400</span>			mA	
$\Delta V_{OUT} / \Delta I_{OUT}$	Load Regulation	$1mA \leq I_{OUT} \leq 400mA$		25	<span style="border: 1px solid black; padding: 0 2px;">45</span>	mV	
$V_{DIF}$	Dropout Voltage	Refer to the following table					
$I_{SS}$	Supply Current	$I_{OUT} = 0mA$		48	75	$\mu A$	
$I_{standby}$	Standby Current	$V_{CE} = 0V$		0.1	8.0	$\mu A$	
$\Delta V_{OUT} / \Delta V_{IN}$	Line Regulation	Set $V_{OUT} + 0.5V \leq V_{IN} \leq 3.6V$ In case that Set $V_{OUT} < 0.8V$ , $1.3V \leq V_{IN} \leq 3.6V$		0.10	<span style="border: 1px solid black; padding: 0 2px;">0.25</span>	%/V	
RR	Ripple Rejection	$f = 10kHz$ , Ripple 0.2Vp-p $V_{IN} = \text{Set } V_{OUT} + 1V$ , $I_{OUT} = 30mA$		60		dB	
$V_{IN}$	Input Voltage*		<span style="border: 1px solid black; padding: 0 2px;">1.0</span>		<span style="border: 1px solid black; padding: 0 2px;">3.6</span>	V	
$\Delta V_{OUT} / \Delta T_{opt}$	Output Voltage Temperature Coefficient	$-40^{\circ}C \leq T_{opt} \leq 85^{\circ}C$		$\pm 60$		ppm/ $^{\circ}C$	
$I_{SC}$	Short Current Limit	$V_{OUT} = 0V$		110		mA	
$V_{CEH}$	CE Input Voltage "H"		<span style="border: 1px solid black; padding: 0 2px;">0.9</span>			V	
$V_{CEL}$	CE Input Voltage "L"				<span style="border: 1px solid black; padding: 0 2px;">0.4</span>	V	
en	Output Noise	$BW = 10Hz$ to $100kHz$ $I_{OUT} = 30mA$ , $V_{OUT} = 0.7V$		30		$\mu V_{rms}$	
$R_{LOW}$	Low Output Nch Tr. ON Resistance (of D version)	$V_{IN} = 2.0V$ , $V_{CE} = 0V$		43		$\Omega$	

All of units are tested and specified under load conditions such that  $T_j \approx T_{opt} = 25^{\circ}C$  except for Output Noise, Ripple Rejection, Output Voltage Temperature Coefficient.

### RECOMMENDED OPERATING CONDITIONS (ELECTRICAL CHARACTERISTICS)

All of electronic equipment should be designed that the mounted semiconductor devices operate within the recommended operating conditions. The semiconductor devices cannot operate normally over the recommended operating conditions, even if when they are used over such conditions by momentary electronic noise or surge. And the semiconductor devices may receive serious damage when they continue to operate over the recommended operating conditions.

• Dropout Voltage by Output Voltage

T<sub>opt</sub>=25°C

Output Voltage V <sub>OUT</sub> (V)	Dropout Voltage V <sub>DIF</sub> (V)		
	Condition	Typ.	Max.
0.7 ≤ V <sub>OUT</sub> < 0.8	I <sub>OUT</sub> =400mA	0.48	0.62
0.8 ≤ V <sub>OUT</sub> < 0.9		0.40	0.54
0.9 ≤ V <sub>OUT</sub> < 1.0		0.36	0.47
1.0 ≤ V <sub>OUT</sub> < 1.2		0.32	0.45
1.2 ≤ V <sub>OUT</sub> < 1.5		0.28	0.38
1.5 ≤ V <sub>OUT</sub>		0.22	0.31

The specification in  is checked and guaranteed by design engineering at -40°C ≤ T<sub>opt</sub> ≤ 85°C.

## TYPICAL APPLICATION

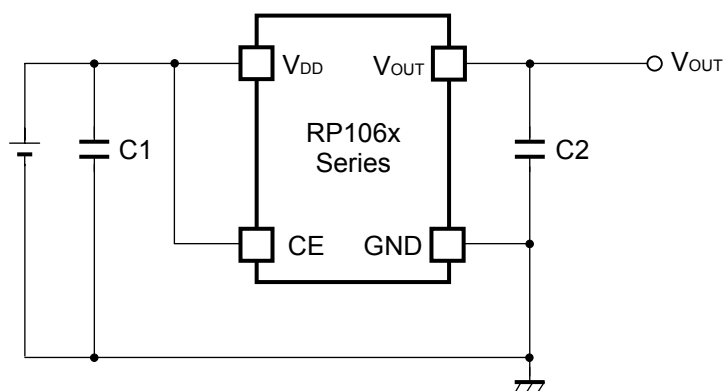

(External Components)

C1, C2 Ceramic 1.0 $\mu$ F MURATA: GRM155B31A105KE15

## TECHNICAL NOTES

When using these ICs, consider the following points:

### Phase Compensation

In these ICs, phase compensation is made for securing stable operation even if the load current is varied. For this purpose, use a capacitor C2 with 1.0 $\mu$ F or more.

If a tantalum capacitor is used, and its ESR (Equivalent Series Resistance) of C2 is large, the loop oscillation may result. Because of this, select C2 carefully considering its frequency characteristics.

### PCB Layout

Make V<sub>DD</sub> and GND lines sufficient. If their impedance is high, noise pickup or unstable operation may result. Connect a capacitor C1 with a capacitance value as much as 1.0 $\mu$ F or more between V<sub>DD</sub> and GND pin, and as close as possible to the pins.

Set external components, especially the output capacitor C2, as close as possible to the ICs, and make wiring as short as possible.

### Impedance of Input pin

CE pull-down constant current circuit is built in the RP106x.

However, if the CE pin is floating and the wiring is long, the malfunction may occur by noise. Therefore, fully evaluation on the actual PCB is necessary.

## TEST CIRCUITS

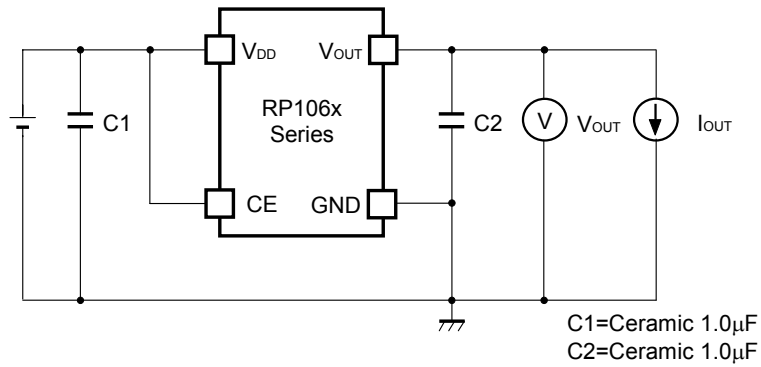

**Basic Test Circuit**

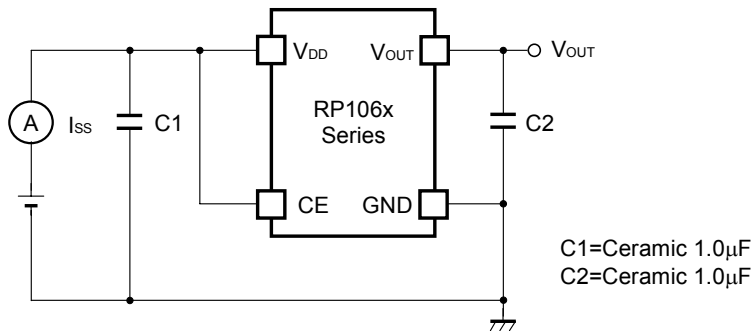

**Supply Current Test Circuit**

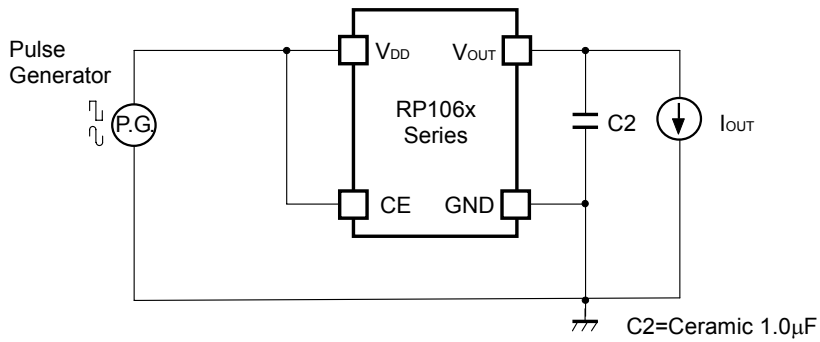

**Ripple Rejection Test Circuit**

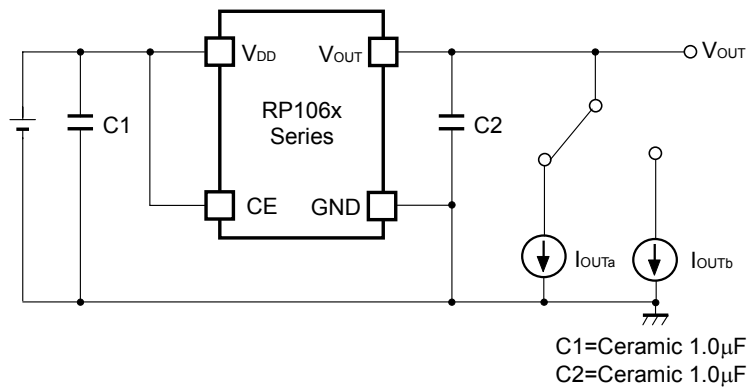

**Load Transient Response Test Circuit**

## ■ Constant Slope Circuits

The RP106x Series is equipped with a constant slope circuit as a soft-start circuit, which allows the output voltage to start up gradually when the CE is turned on.

The constant slope circuit minimizes the inrush current at the start-up and also prevents the overshoot of the output voltage.

The capacitor to create the start-up slope is built in the IC that does not require any external components. The start-up time and the start-up slope angle are fixed inside the IC. For more details, please refer to the graph 15 of “Inrush Current Characteristics Example”.

**Inrush Current Characteristics Example (C<sub>1</sub>=1.0μF, T<sub>opt</sub>=25°C)**

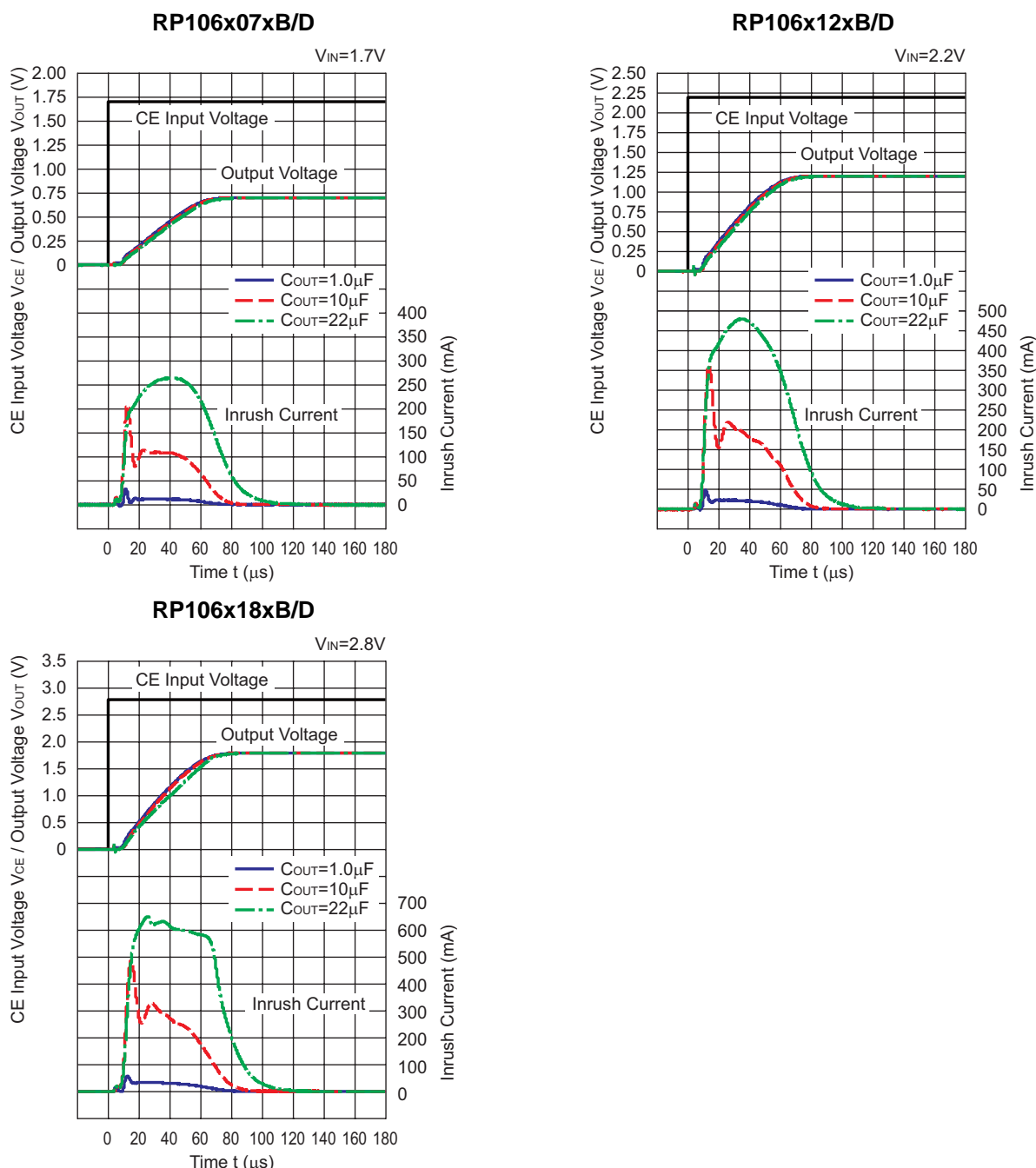

## TYPICAL CHARACTERISTICS

### 1) Output Voltage vs. Output Current ( $T_{opt}=25^{\circ}C$ )

RP106x07xx

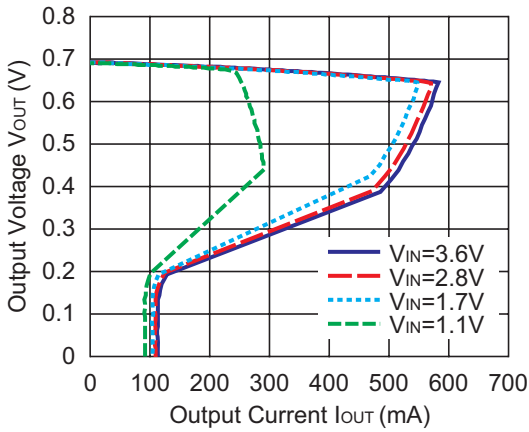

RP106x12xx

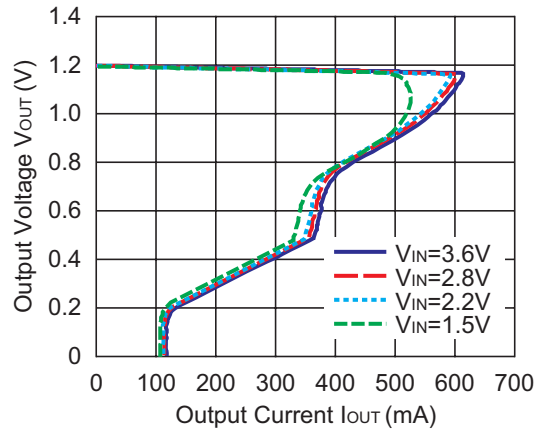

RP106x18xx

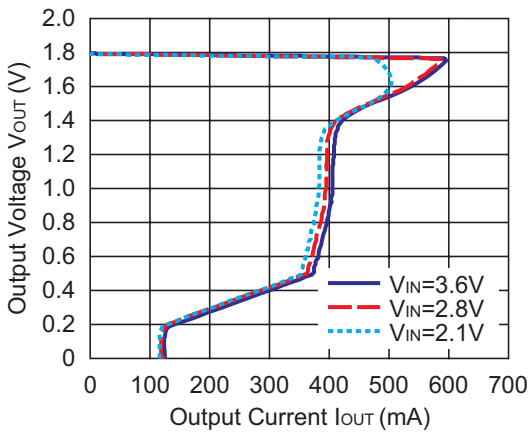

### 2) Output Voltage vs. Input Voltage ( $T_{opt}=25^{\circ}C$ )

RP106x07xx

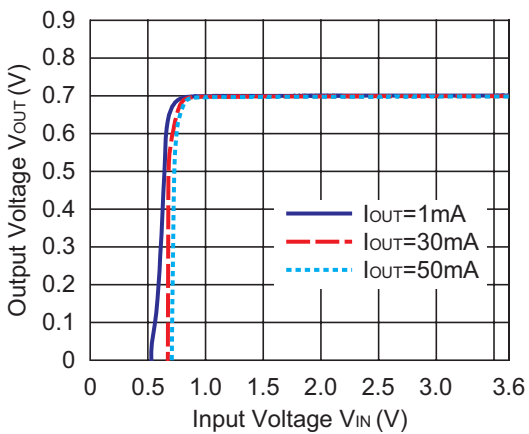

RP106x12xx

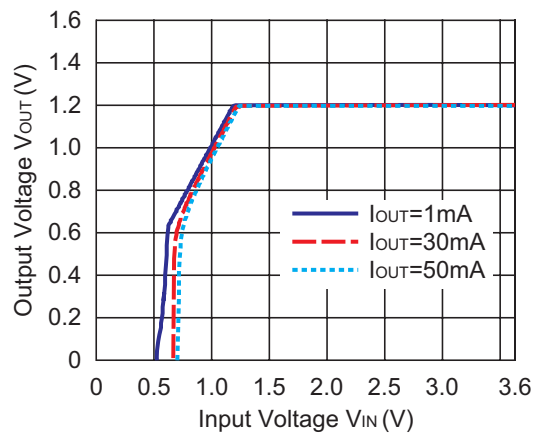

RP106x18xx

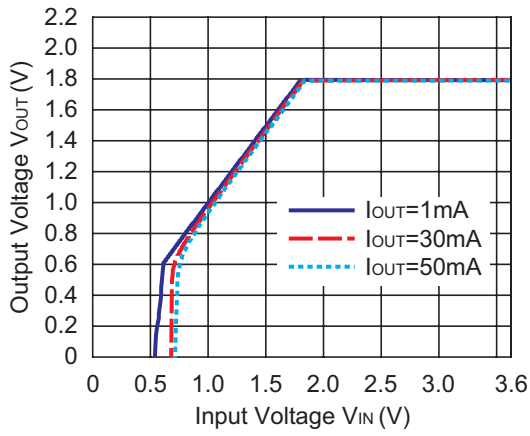

3) Supply Current vs. Input Voltage ( $T_{opt}=25^{\circ}C$ )

RP106x07xx

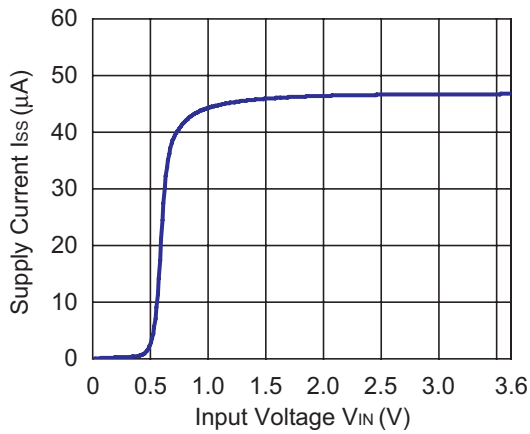

RP106x12xx

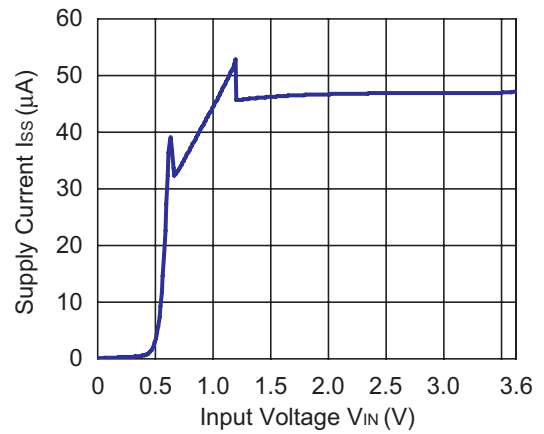

RP106x18xx

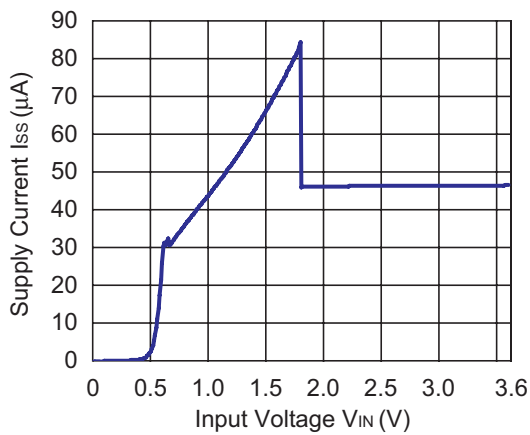

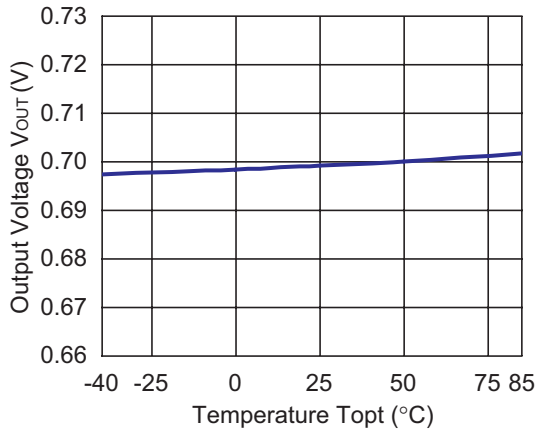
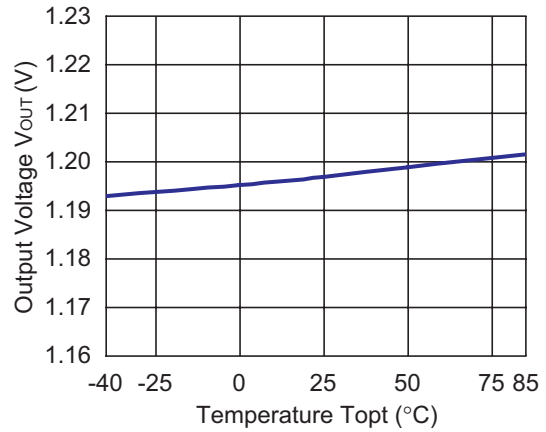
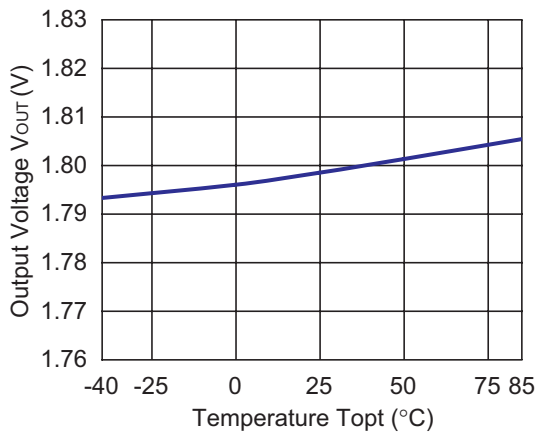
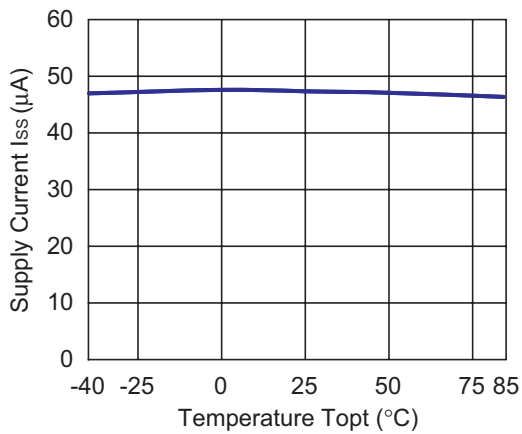
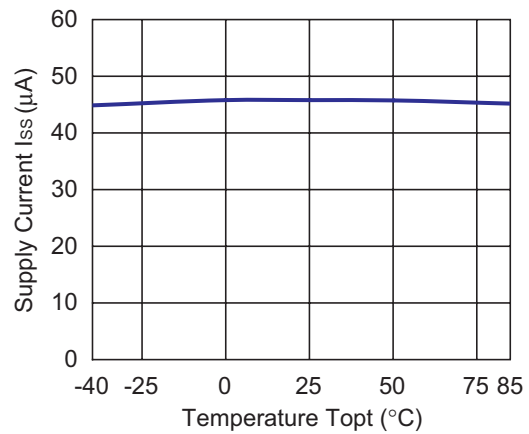
**4) Output Voltage vs. Temperature****RP106x07xx****RP106x12xx****RP106x18xx****5) Supply Current vs. Temperature****RP106x07xx****RP106x12xx**

RP106x18xx

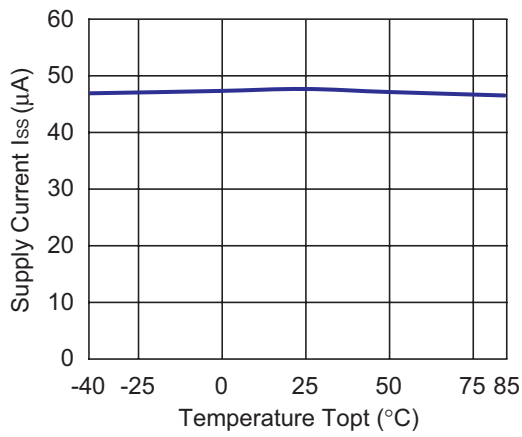

6) Dropout Voltage vs. Output Current

RP106x07xx

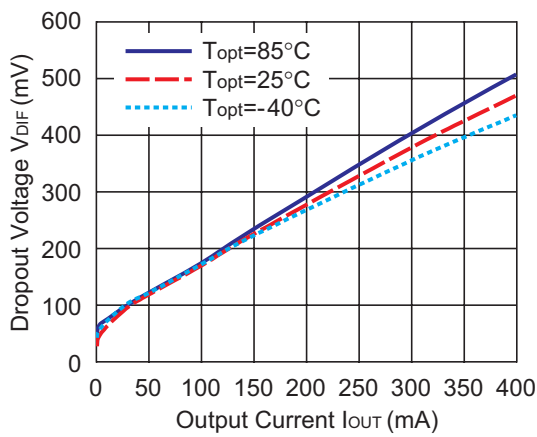

RP106x12xx

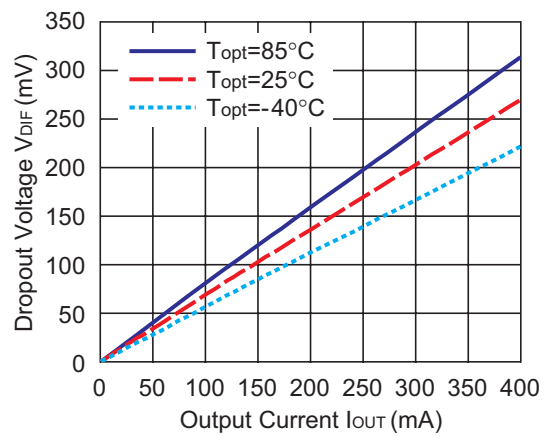

RP106x18xx

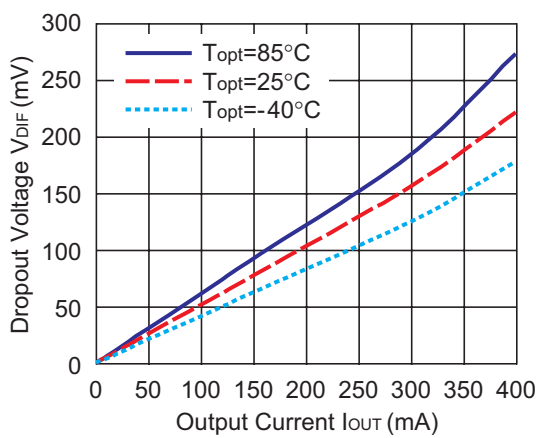

7) Dropout Voltage vs Set Output Voltage (Topt=25°C)

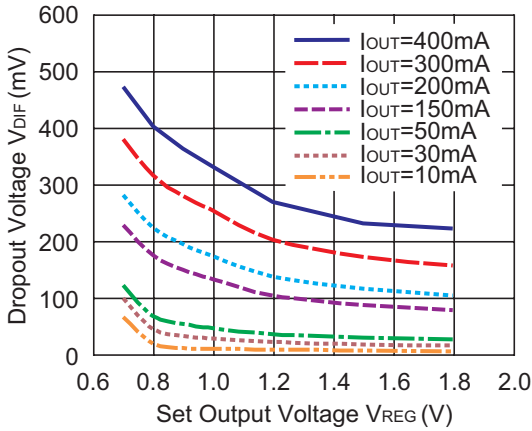

8) Minimum Operating Voltage

RP106x07xx

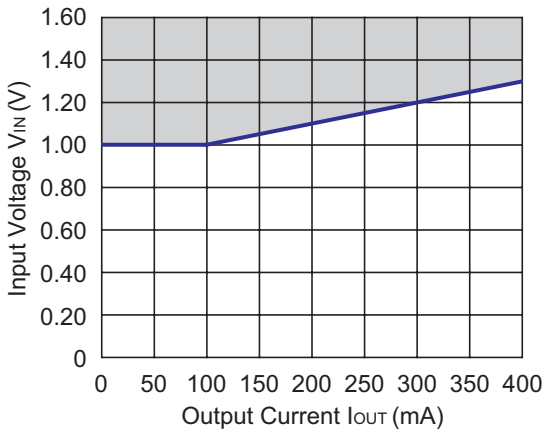

Hatched area is available for 0.7V output

9) Ripple Rejection vs. Input Bias Voltage (C1=none, C2=1.0μF, Ripple=0.2Vp-p, Topt=25°C)

RP106x07xx

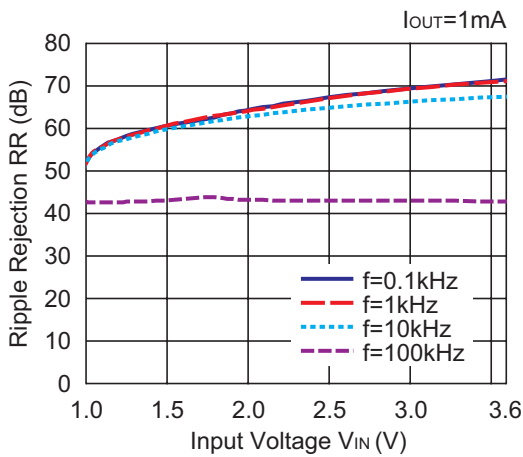

RP106x07xx

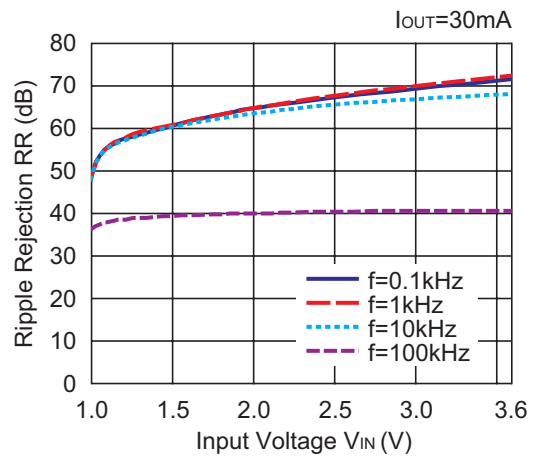

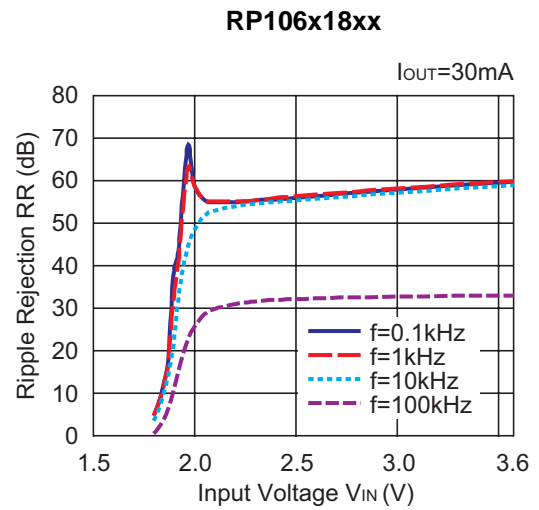
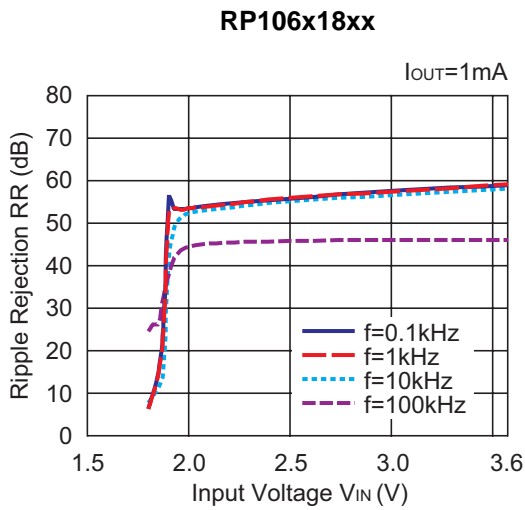

10) Ripple Rejection vs. Frequency ( $C1=\text{none}$ ,  $C2=1.0\mu\text{F}$ , Ripple=0.1Vp-p,  $T_{opt}=25^\circ\text{C}$ )

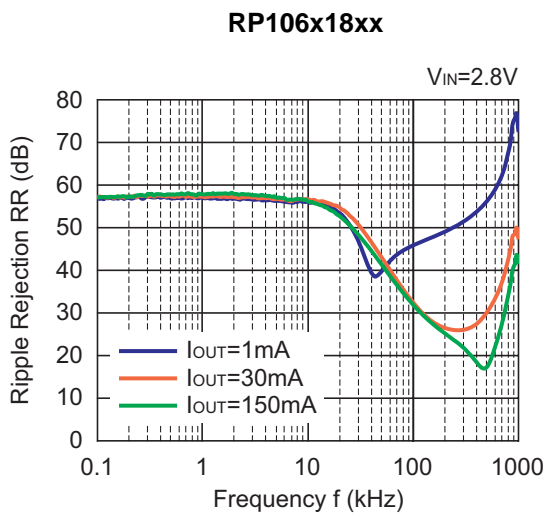
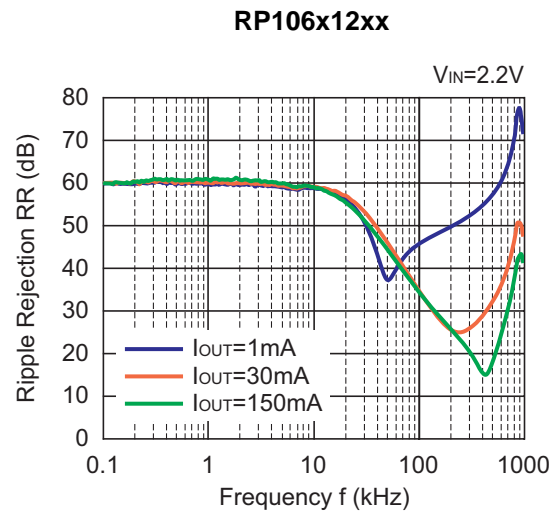
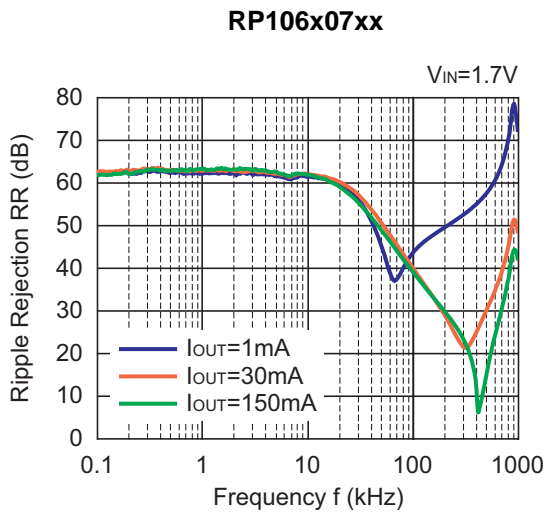

11) Input Transient Response (C1=none, C2=1.0μF, I<sub>OUT</sub>=30mA, tr=tf=5μs, T<sub>opt</sub>=25°C)

RP106x07xx

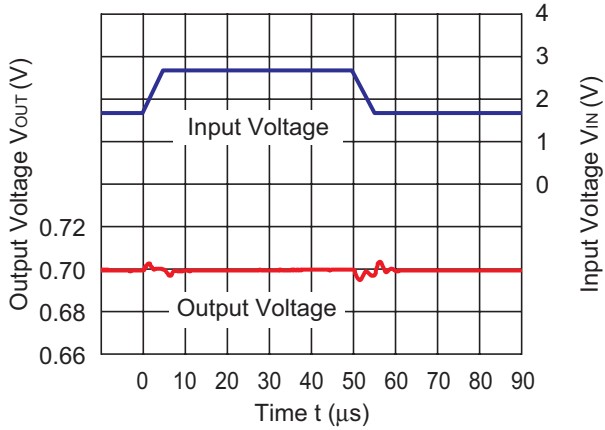

RP106x12xx

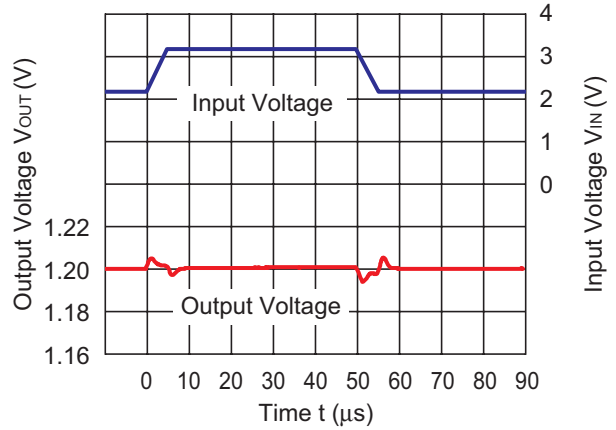

RP106x18xx

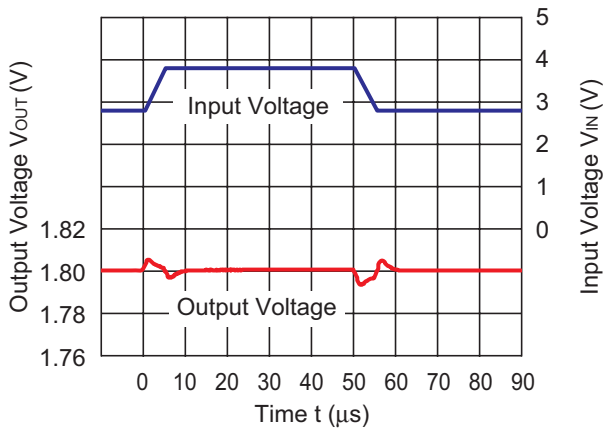

12) Load Transient Response (C1=C2=1.0μF, tr=tf=5μs, T<sub>opt</sub>=25°C)

RP106x07xx

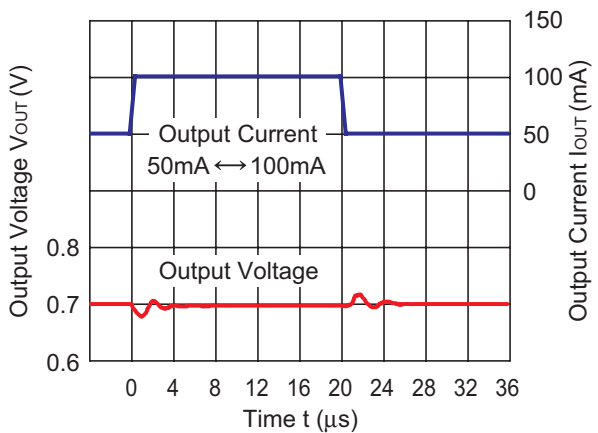

RP106x07xx

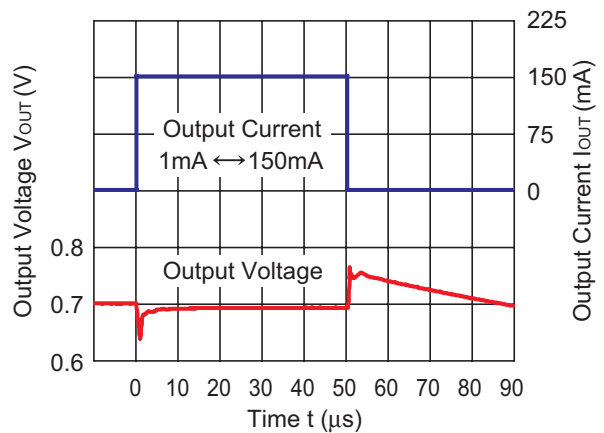

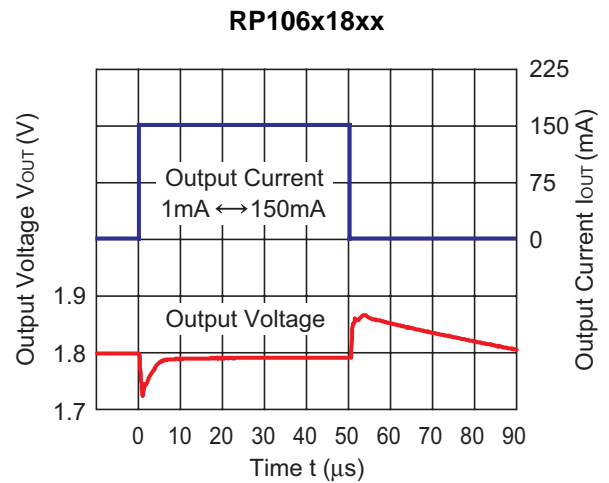
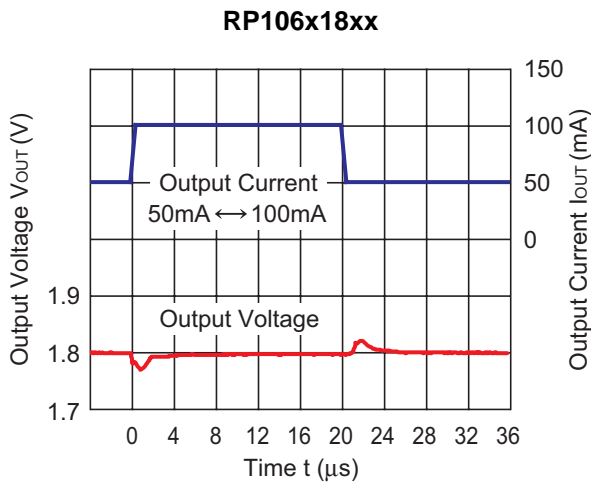
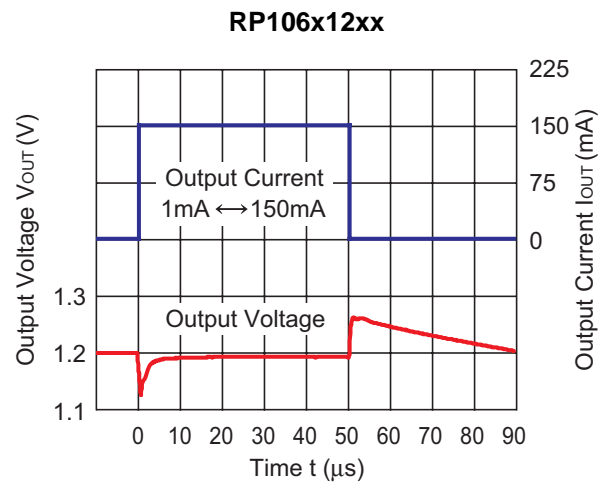
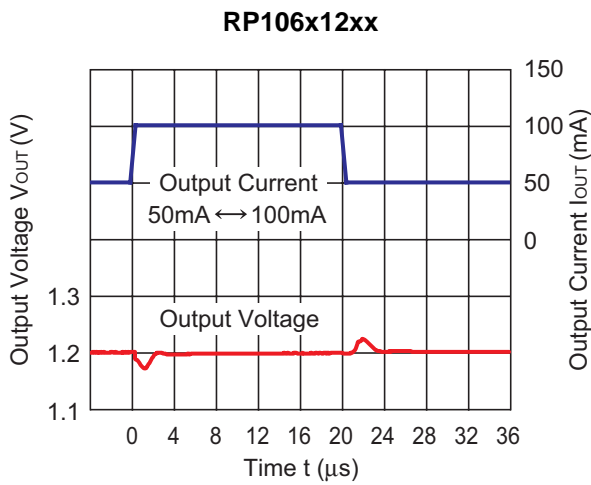

**13) Turn On Speed with CE pin ( $C1=C2=1.0\mu$ F,  $T_{opt}=25^{\circ}$ C)**

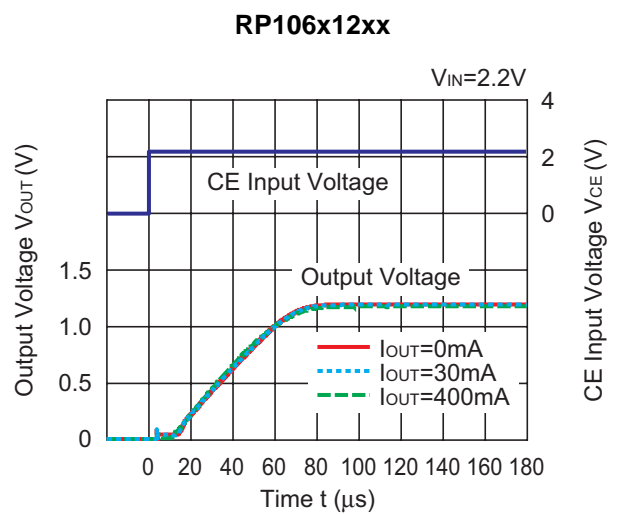
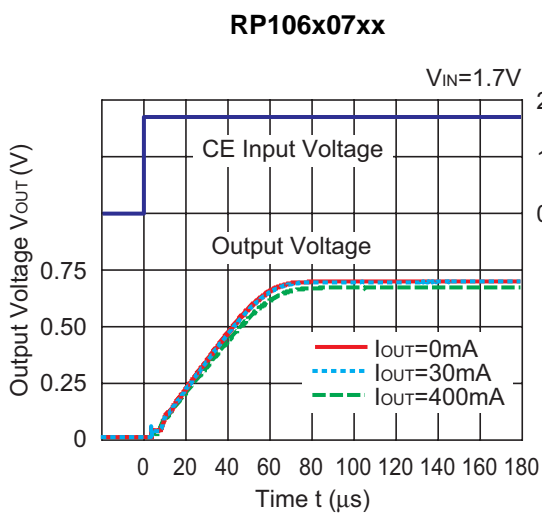

RP106x18xx

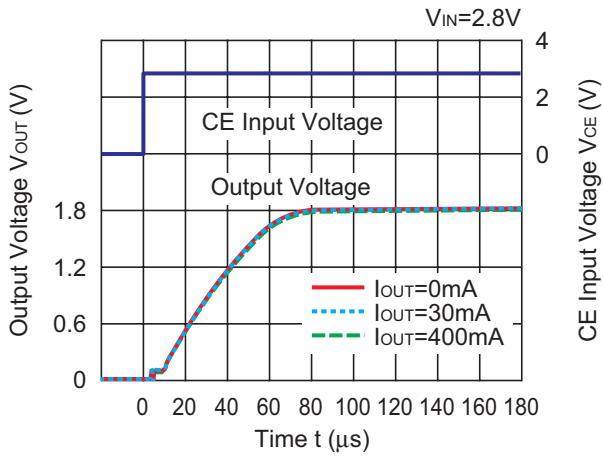

14) Turn Off Speed with CE pin ( $C1=C2=1.0\mu F$ ,  $T_{opt}=25^{\circ}C$ )

RP106x07xx

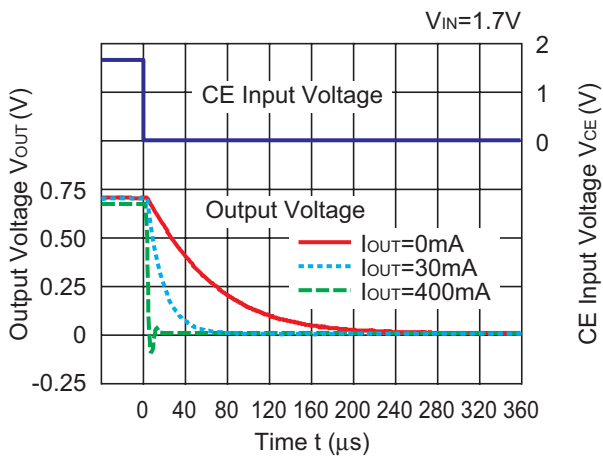

RP106x12xx

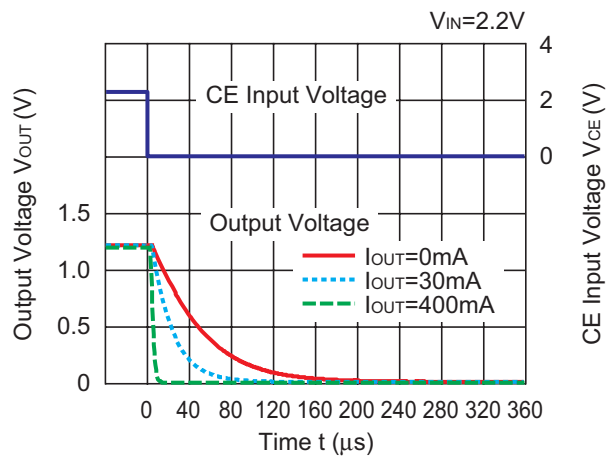

RP106x18xx

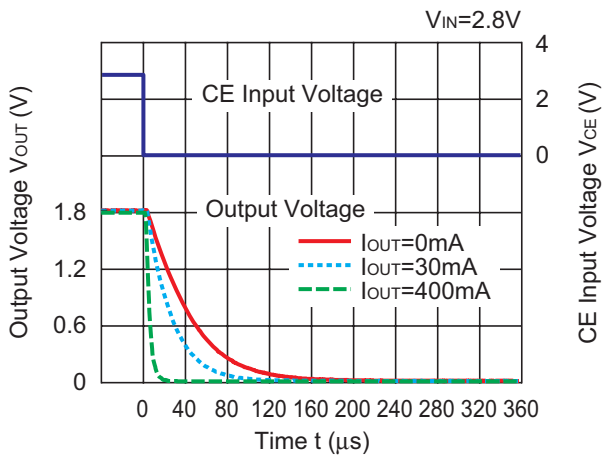

15) Inrush Current at Start up ( $C_1=1.0\mu\text{F}$ ,  $T_{\text{opt}}=25^\circ\text{C}$ )

RP106x07xx

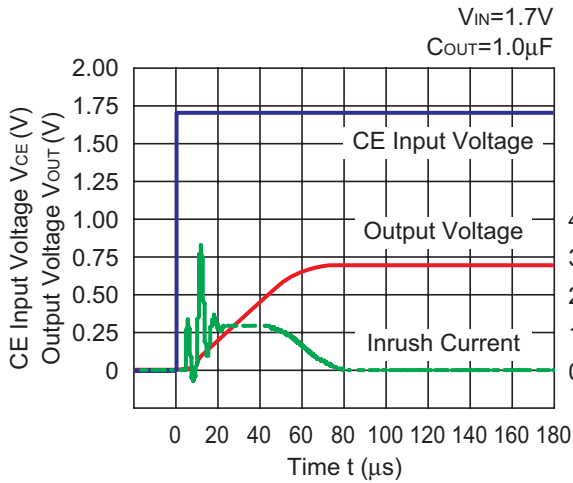

RP106x07xx

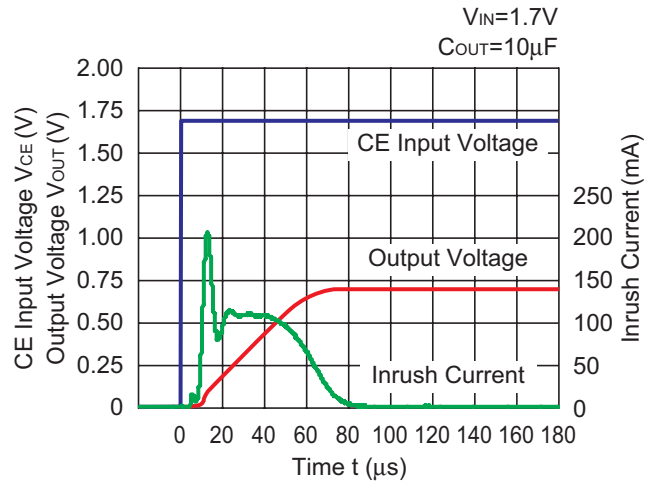

RP106x07xx

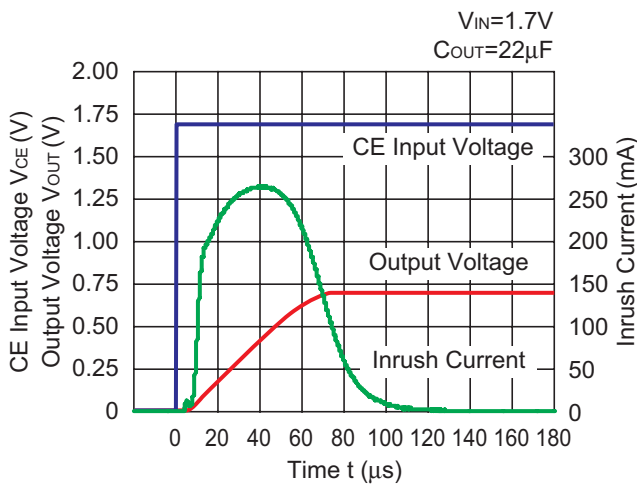

RP106x12xx

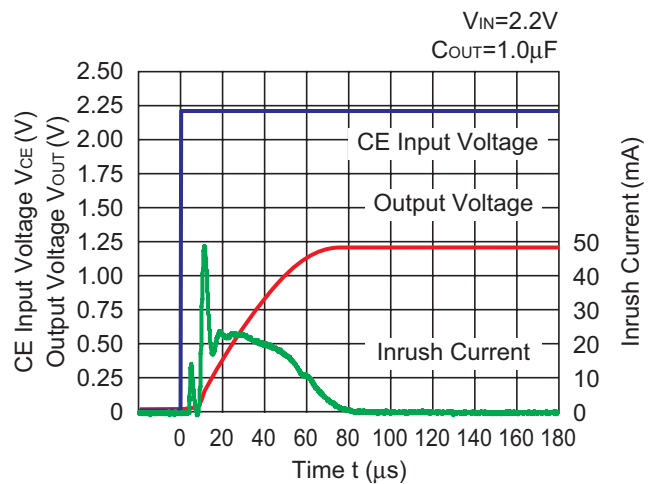

RP106x12xx

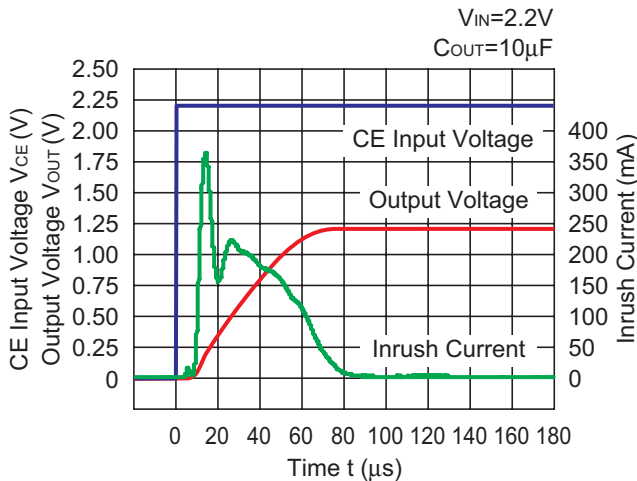

RP106x12xx

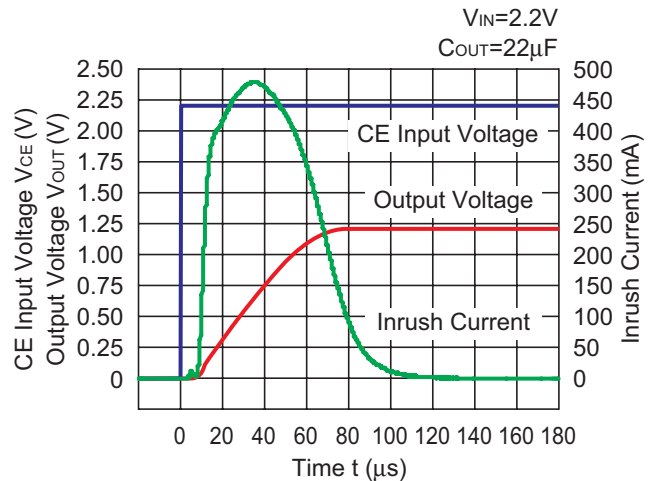

RP106x18xx

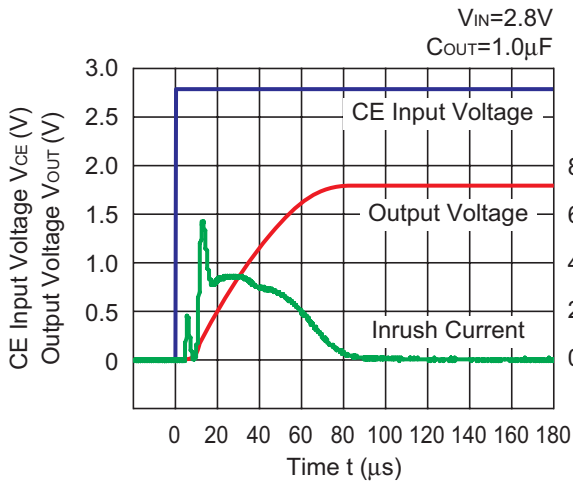

RP106x18xx

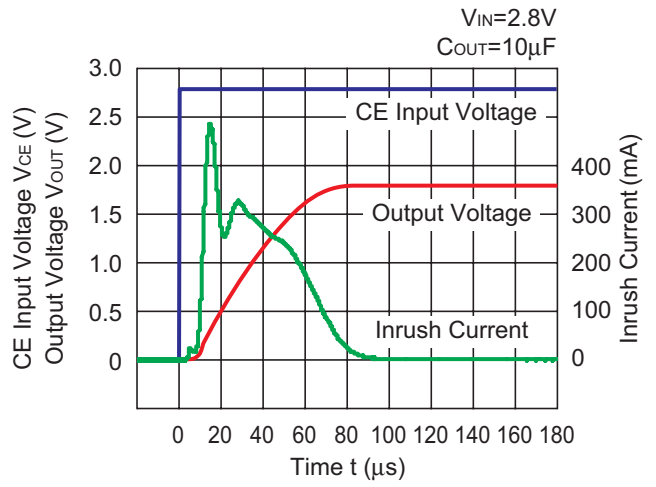

RP106x18xx

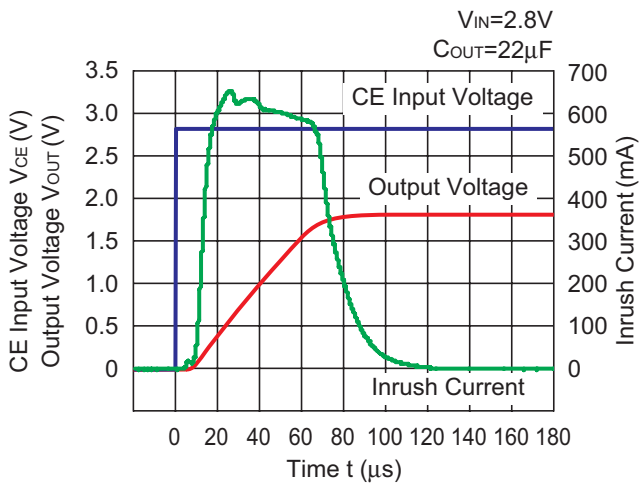

## ESR vs. Output Current

When using these ICs, consider the following points:

The relations between  $I_{OUT}$  (Output Current) and ESR of an output capacitor are shown below.

The conditions when the white noise level is under  $40\mu\text{V}$  (Avg.) are marked as the hatched area in the graph.

### Measurement conditions

Frequency Band: 10Hz to 3MHz

Temperature :  $-40^{\circ}\text{C}$  to  $85^{\circ}\text{C}$

C1, C2 :  $1.0\mu\text{F}$  MURATA GRM155B31A105KE15

If other than ceramic capacitors such as tantalum, the ESR of the capacitor might be higher than expected. This graph shows the stable area with ESR limit. In the actual evaluation, we used Murata GRM155B31A105KE15, therefore, bias characteristics of the same kind of ceramic capacitors are considered.

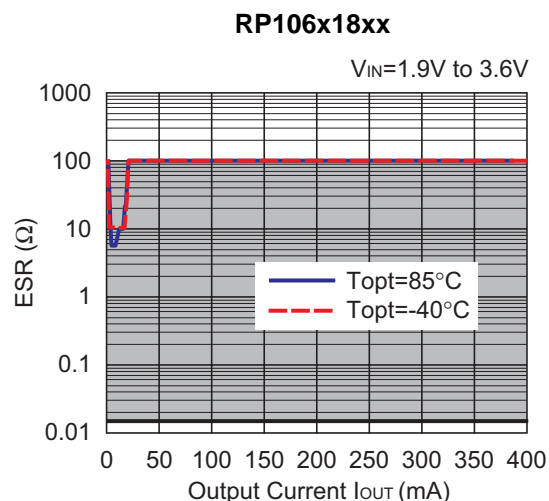
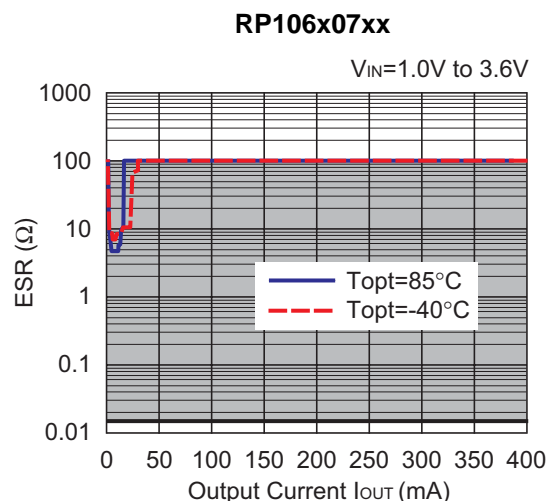



1. The products and the product specifications described in this document are subject to change or discontinuation of production without notice for reasons such as improvement. Therefore, before deciding to use the products, please refer to Ricoh sales representatives for the latest information thereon.
2. The materials in this document may not be copied or otherwise reproduced in whole or in part without prior written consent of Ricoh.
3. Please be sure to take any necessary formalities under relevant laws or regulations before exporting or otherwise taking out of your country the products or the technical information described herein.
4. The technical information described in this document shows typical characteristics of and example application circuits for the products. The release of such information is not to be construed as a warranty of or a grant of license under Ricoh's or any third party's intellectual property rights or any other rights.
5. The products listed in this document are intended and designed for use as general electronic components in standard applications (office equipment, telecommunication equipment, measuring instruments, consumer electronic products, amusement equipment etc.). Those customers intending to use a product in an application requiring extreme quality and reliability, for example, in a highly specific application where the failure or misoperation of the product could result in human injury or death (aircraft, spacevehicle, nuclear reactor control system, traffic control system, automotive and transportation equipment, combustion equipment, safety devices, life support system etc.) should first contact us.
6. We are making our continuous effort to improve the quality and reliability of our products, but semiconductor products are likely to fail with certain probability. In order to prevent any injury to persons or damages to property resulting from such failure, customers should be careful enough to incorporate safety measures in their design, such as redundancy feature, firecontainment feature and fail-safe feature. We do not assume any liability or responsibility for any loss or damage arising from misuse or inappropriate use of the products.
7. Anti-radiation design is not implemented in the products described in this document.
8. Please contact Ricoh sales representatives should you have any questions or comments concerning the products or the technical information.

## RICOH COMPANY., LTD. Electronic Devices Company



■ Ricoh presented with the Japan Management Quality Award for 1999.  
Ricoh continually strives to promote customer satisfaction, and shares the achievements of its management quality improvement program with people and society.



■ Ricoh awarded ISO 14001 certification.  
The Ricoh Group was awarded ISO 14001 certification, which is an international standard for environmental management systems, at both its domestic and overseas production facilities. Our current aim is to obtain ISO 14001 certification for all of our business offices.

<http://www.ricoh.com/LSI/>

### RICOH COMPANY, LTD. Electronic Devices Company

● Higashi-Shinagawa Office (International Sales)  
3-32-3, Higashi-Shinagawa, Shinagawa-ku, Tokyo 140-8655, Japan  
Phone: +81-3-5479-2857 Fax: +81-3-5479-0502

### RICOH EUROPE (NETHERLANDS) B.V.

● Semiconductor Support Centre  
Prof. W.H.Keesomlaan 1, 1183 DL Amstelveen, The Netherlands  
P.O.Box 114, 1180 AC Amstelveen  
Phone: +31-20-5474-309 Fax: +31-20-5474-791

### RICOH ELECTRONIC DEVICES KOREA Co., Ltd.

11 floor, Haesung 1 building, 942, Daechidong, Gangnamgu, Seoul, Korea  
Phone: +82-2-2135-5700 Fax: +82-2-2135-5705

### RICOH ELECTRONIC DEVICES SHANGHAI Co., Ltd.

Room403, No.2 Building, 690#Bi Bo Road, Pu Dong New district, Shanghai 201203,  
People's Republic of China  
Phone: +86-21-5027-3200 Fax: +86-21-5027-3299

### RICOH COMPANY, LTD. Electronic Devices Company

● Taipei office  
Room109, 10F-1, No.51, Hengyang Rd., Taipei City, Taiwan (R.O.C.)  
Phone: +886-2-2313-1621/1622 Fax: +886-2-2313-1623



Ricoh completed the organization of the Lead-free production for all of our products. After Apr. 1, 2006, we will ship out the lead free products only. Thus, all products that will be shipped from now on comply with RoHS Directive.