120mA LDO REGULATOR

NO.EA-082-0607

OUTLINE

The R1141Q Series consist of CMOS-based voltage regulator ICs with high output voltage accuracy, low supply current, low ON-resistance, and high ripple rejection. Each of these voltage regulator ICs consists of a voltage reference unit, an error amplifier, resistors for setting Output Voltage, a current limit circuit, and a chip enable circuit.

Output Current Limit circuit is embedded in the R1141Q Series to prevent the break down of the IC caused by excess current.

Chip enable circuit realizes standby mode and makes consumption current extremely small.

These ICs perform with low dropout voltage and a chip enable function. The line transient response and load transient response of the R1141Q Series are excellent, making these ICs very suitable for the power supply for hand-held communication equipment.

Their output voltage is internally fixed with high accuracy. Since the package for these ICs is SC-82AB (Super Mini-mold) package, high density mounting of the ICs on boards is possible.

FEATURES

- Ultra-Low Supply Current..... Typ. 90 μ A
- Standby Mode Typ. 0.1 μ A
- Low Dropout Voltage..... Typ. 0.15V ($I_{OUT}=100\text{mA}$, Output Voltage=3.0V Type)
- High Ripple Rejection Typ. 75dB ($V_{OUT} \leq 2.4\text{V}$)
..... Typ. 70dB ($V_{OUT} \geq 2.5\text{V}$) ($f=1\text{kHz}$)
- Low Temperature-Drift Coefficient of Output Voltage... Typ. $\pm 100\text{ppm}/^\circ\text{C}$
- Excellent Line Regulation Typ. 0.02%/V
- High Output Voltage Accuracy $\pm 1.5\%$ or $\pm 30\text{mV}$ ($V_{OUT} \leq 2.0\text{V}$)
- Excellent Dynamic Response
- Small Package SC-82AB (Super Mini-mold)
- Output Voltage 1.5V to 4.0V
- Built-in Chip Enable Circuit (B/D : active high)
- Built-in Fold-back Protection Circuit..... Typ. 40mA (Short Current)
- Ceramic capacitor can be used for Output pin Recommended value is 2.2 μ F or more.

APPLICATIONS

- Power source for cellular phones such as GSM, CDMA and various kinds of PCS.
- Power source for electrical appliances such as cameras, VCRs and camcorders, and hand-held communication equipment.
- Power source for battery-powered equipment.
- Very stable Voltage Reference

BLOCK DIAGRAMS

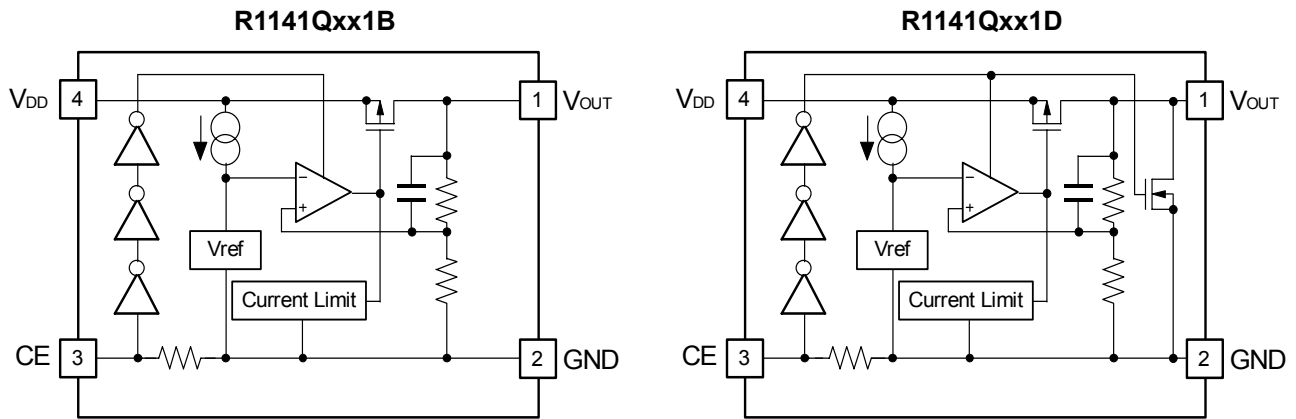

SELECTION GUIDE

The output voltage, mask option, and the taping type for the ICs can be selected at the user's request. The selection can be made with designating the part number as shown below;

R1141Qxx1x-xx-X ← Part Number
 ↑ ↑ ↑ ↑ ↑
 a b c d e

Code	Contents
a	Designation of Package Type Q: SC-82AB (Super Mini-mold)
b	Setting Output Voltage (V_{OUT}): Stepwise setting with a step of 0.1V in the range of 1.5V to 4.0V is possible.
c	Designation of Mask Option : B: Without auto discharge function at OFF state. D: With auto discharge function at OFF state.
d	Designation of Taping Type : Ex. TR (refer to Taping Specifications.)
e	Designation of composition of pin plating -F : Lead free plating

PIN CONFIGURATION

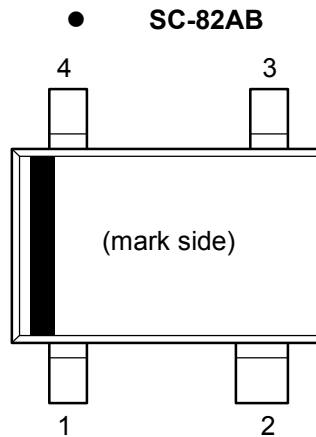

PIN DESCRIPTION

Pin No	Symbol	Pin Description
1	V_{OUT}	Output Pin
2	GND	Ground Pin
3	CE	Chip Enable Pin
4	V_{DD}	Input Pin

ABSOLUTE MAXIMUM RATINGS

Symbol	Item	Rating	Unit
V_{IN}	Input Voltage	6.5	V
V_{CE}	Input Voltage (CE Pin)	6.5	V
V_{OUT}	Output Voltage	-0.3 to $V_{IN} + 0.3$	V
I_{OUT}	Output Current	140	mA
P_D	Power Dissipation (SC-82AB)*	380	mW
T_{opt}	Operating Temperature Range	-40 to 85	°C
T_{stg}	Storage Temperature Range	-55 to 125	°C

*) For Power Dissipation, please refer to PACKAGE INFORMATION to be described.

ELECTRICAL CHARACTERISTICS

• R1141Qxx1B/D

T_{opt}=25°C

Symbol	Item	Conditions	Min.	Typ.	Max.	Unit
V _{OUT}	Output Voltage	V _{IN} = Set V _{OUT} +1.0V 1mA ≤ I _{OUT} ≤ 30mA(*1)	×0.985 (-30mV)		×1.015 (+30mV)	V
I _{OUT}	Output Current	V _{IN} -V _{OUT} =1.0V	120			mA
ΔV _{OUT} /ΔI _{OUT}	Load Regulation	V _{IN} = Set V _{OUT} +1.0V 1mA ≤ I _{OUT} ≤ 120mA		12	40	mV
V _{DIF}	Dropout Voltage	Refer to the ELECTRICAL CHARACTERISTICS by OUTPUT VOLTAGE				
I _{SS}	Supply Current	V _{IN} = Set V _{OUT} +1.0V		90	160	μA
I _{standby}	Supply Current (Standby)	V _{IN} =V _{CE} = Set V _{OUT} +1.0V		0.1	1.0	μA
ΔV _{OUT} /ΔV _{IN}	Line Regulation	Set V _{OUT} +0.5V ≤ V _{IN} ≤ 6.0V I _{OUT} = 30mA (In case that V _{OUT} ≤ 1.6V, 2.2V ≤ V _{IN} ≤ 6.0V)		0.02	0.10	%/V
RR	Ripple Rejection	f = 1kHz, Ripple 0.5Vp-p V _{IN} = Set V _{OUT} +1V, I _{OUT} = 30mA (In case that V _{OUT} ≤ 1.7V, V _{IN} -V _{OUT} =1.2V)		75 (70) (*2)		dB
V _{IN}	Input Voltage		2.2		6.0	V
ΔV _{OUT} /ΔT _{opt}	Output Voltage Temperature Coefficient	I _{OUT} =30mA -40°C ≤ T _{opt} ≤ 85°C		±100		ppm/ °C
I _{lim}	Short Current Limit	V _{OUT} =0V		40		mA
R _{PU}	CE Pull-up resistance		0.7	2.0	8.0	MΩ
V _{CEH}	CE Input Voltage "H"		1.5		V _{IN}	V
V _{CEL}	CE Input Voltage "L"		0.0		0.3	V
en	Output Noise	BW=10Hz to 100kHz		30		μVrms
R _{LOW}	Low Output Nch Tr. ON Resistance (of D version)	V _{CE} =0V		60		Ω

*1: ±30mV Tolerance at V_{OUT} ≤ 2.0V*2: 70dB at V_{OUT} ≥ 2.5V

• ELECTRICAL CHARACTERISTICS by OUTPUT VOLTAGE

Output Voltage V_{OUT} (V)	Dropout Voltage V_{DIF} (V)		
	Condition	Typ.	Max.
$V_{OUT} = 1.5$	$I_{OUT} = 120\text{mA}$	0.36	0.70
$V_{OUT} = 1.6$		0.32	0.60
$V_{OUT} = 1.7$		0.30	0.50
$1.8 \leq V_{OUT} \leq 2.0$		0.28	0.40
$2.1 \leq V_{OUT} \leq 2.7$		0.24	0.35
$2.8 \leq V_{OUT} \leq 4.0$		0.18	0.28

TECHNICAL NOTES

When using these ICs, consider the following points:

Phase Compensation

In these ICs, phase compensation is made for securing stable operation even if the load current is varied. For this purpose, be sure to use a $2.2\mu\text{F}$ or more capacitor C_{OUT} with good frequency characteristics and ESR (Equivalent Series Resistance).

(Note: When the additional ceramic capacitors are connected to the Output Pin with Output capacitor for phase compensation, the operation might be unstable. Because of this, test these ICs with as same external components as ones to be used on the PCB.)

PCB Layout

Make V_{DD} and GND lines sufficient. When their impedance is high, picking up the noise or unstable operation may result. Connect a capacitor with as much as $1.0\mu\text{F}$ capacitor between V_{DD} and GND pin as close as possible.

Set external components, especially output capacitor as close as possible to the ICs and make wiring as short as possible.

TYPICAL APPLICATION

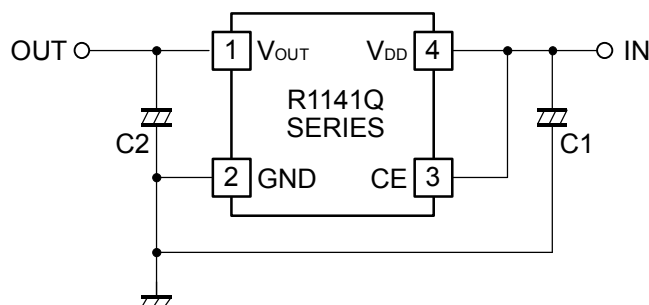

(External Components)
Output Capacitor; Ceramic Type $C1=1.0\mu\text{F}$ $C2=2.2\mu\text{F}$

TEST CIRCUITS

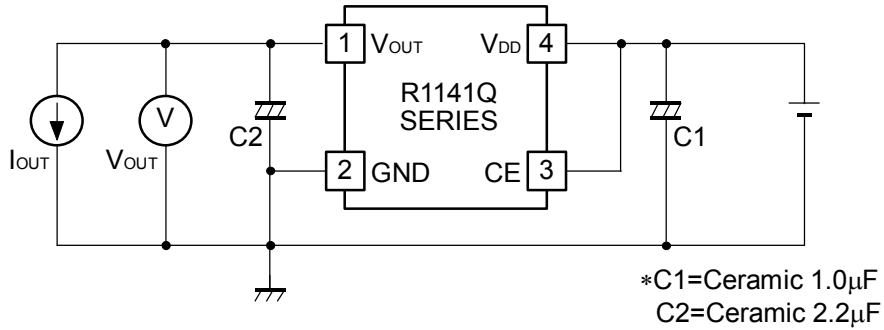

Fig.1 Standard test Circuit

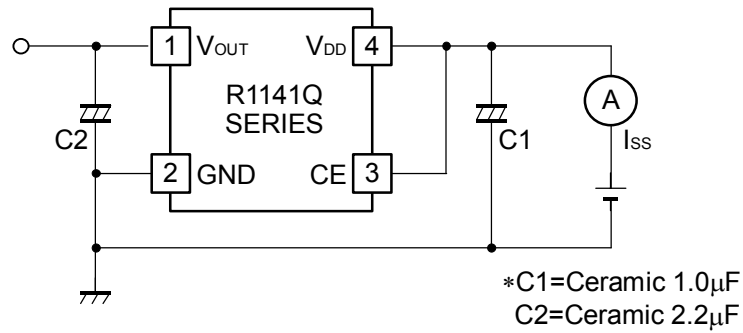

Fig.2 Supply Current Test Circuit

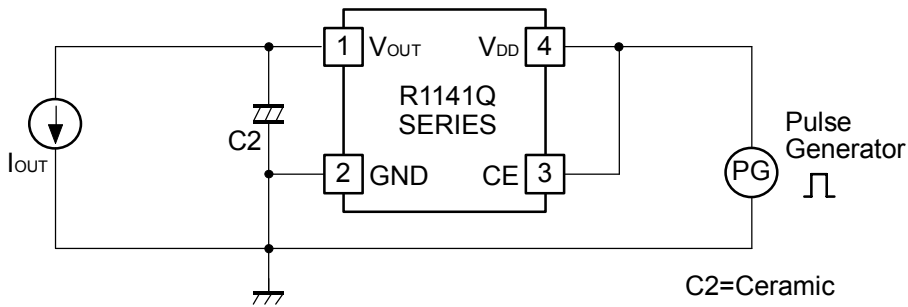

Fig.3 Ripple Rejection, Line Transient Response Test Circuit

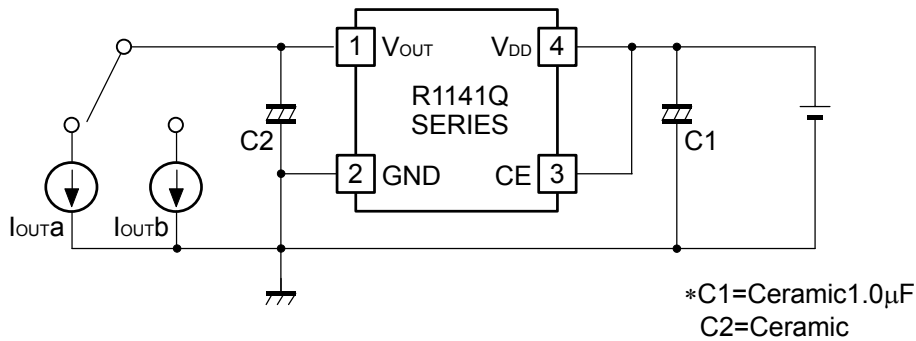
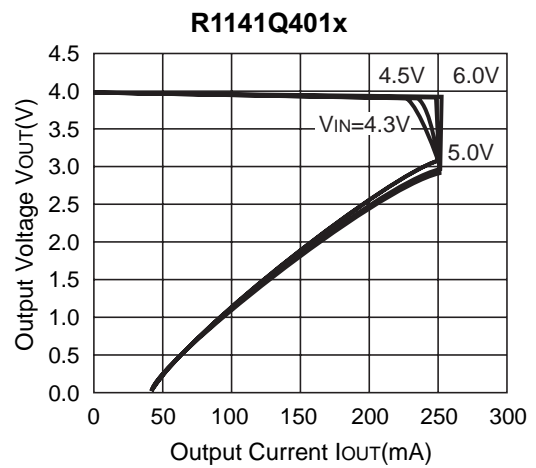
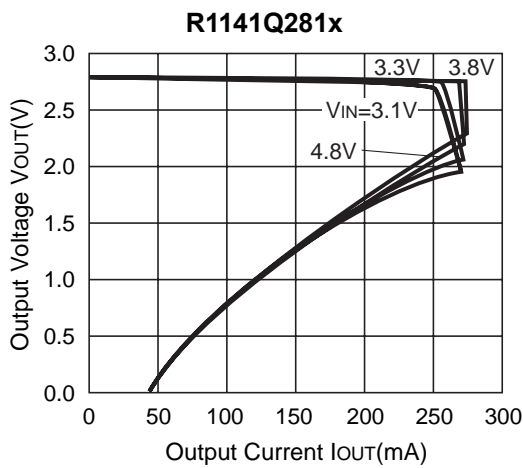
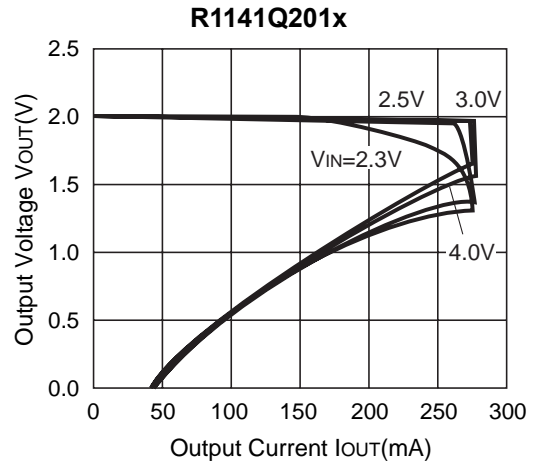
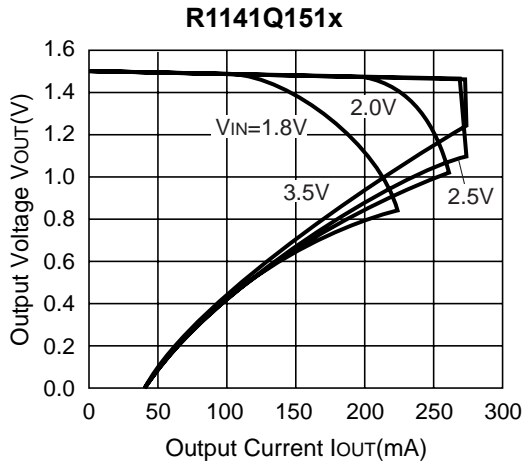

Fig.4 Load Transient Response Test Circuit

TYPICAL CHARACTERISTICS

1) Output Voltage vs. Output Current



2) Output Voltage vs. Input Voltage

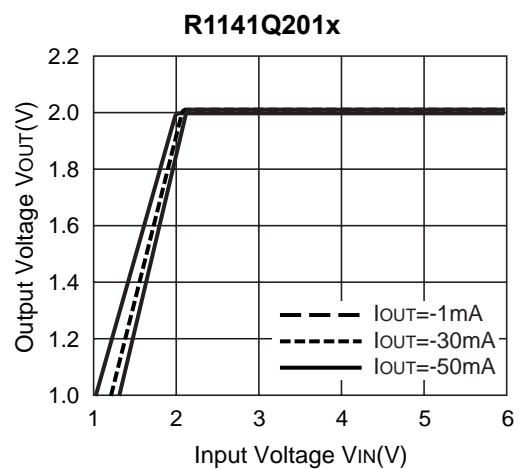
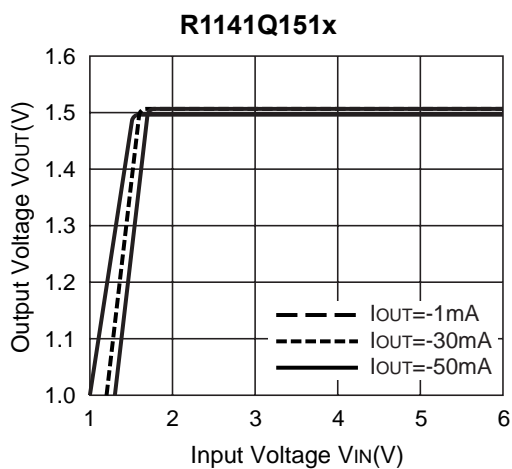

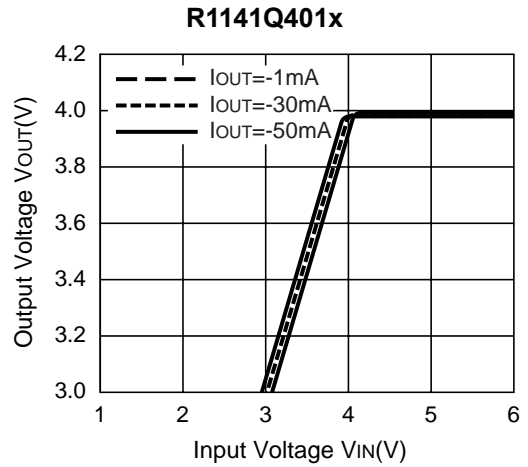
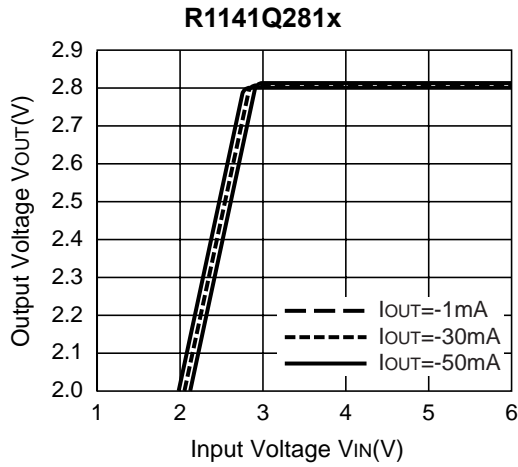

3) Dropout Voltage vs. Output Current

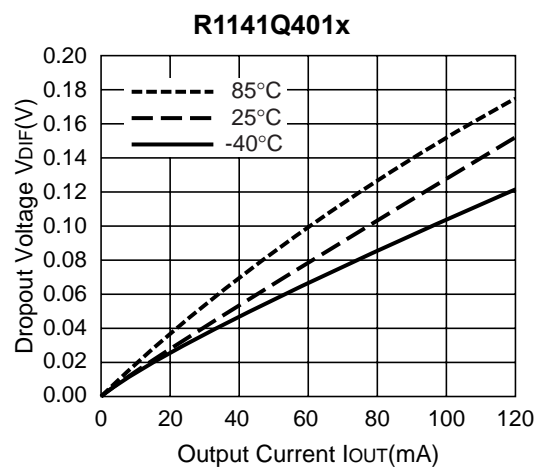
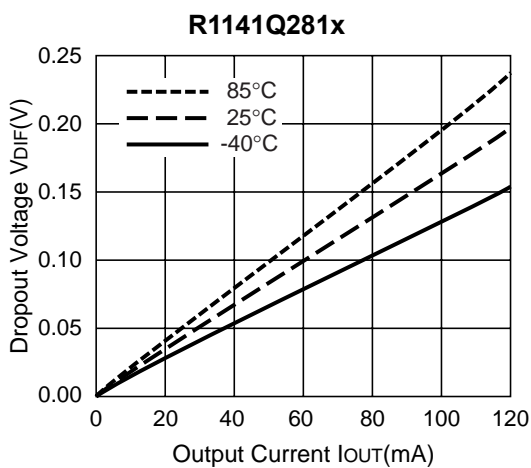
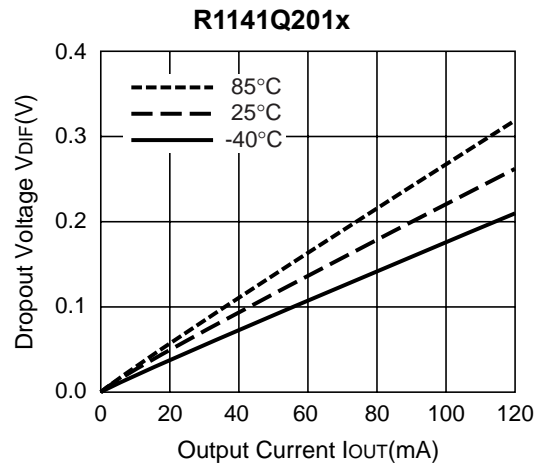
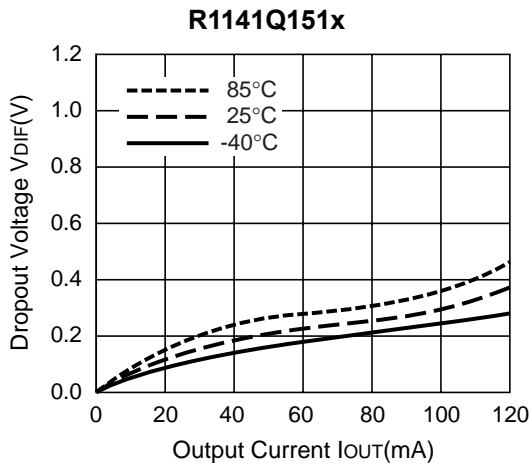

4) Output Voltage vs. Temperature

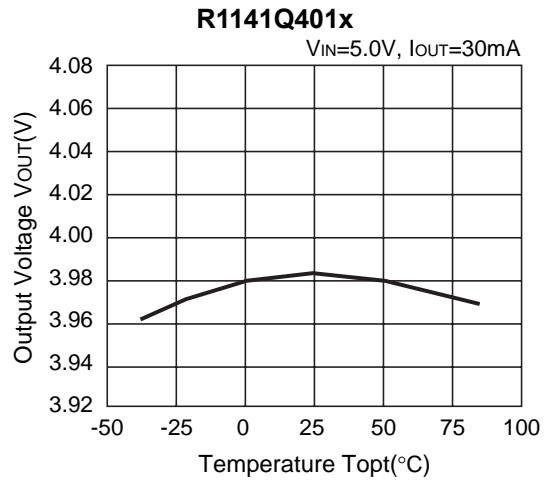
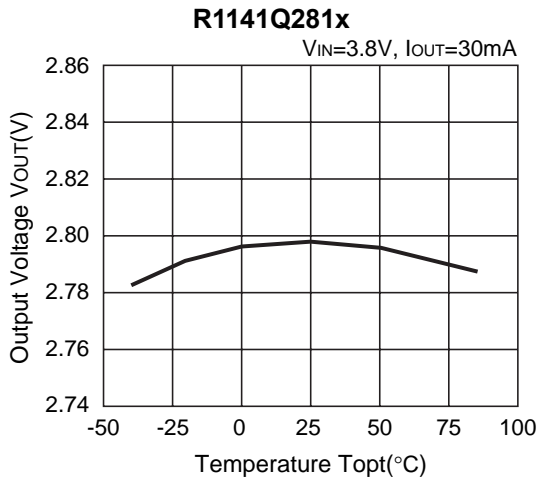
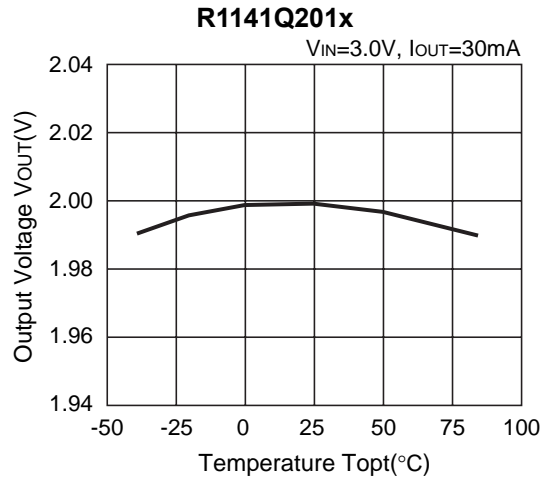
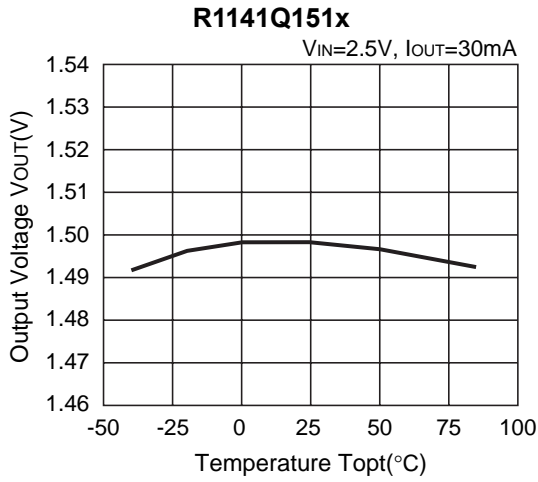

5) Supply Current vs. Input Voltage (Topt=25°C)

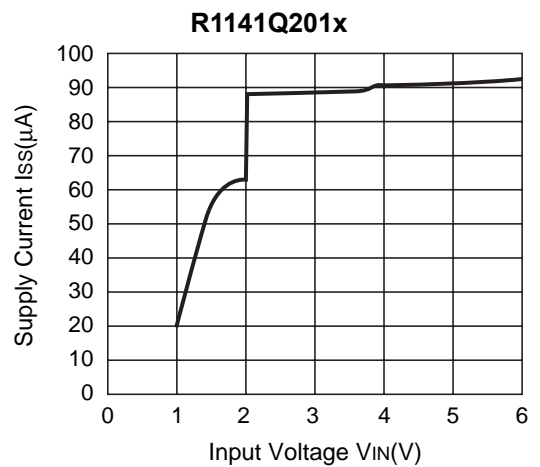
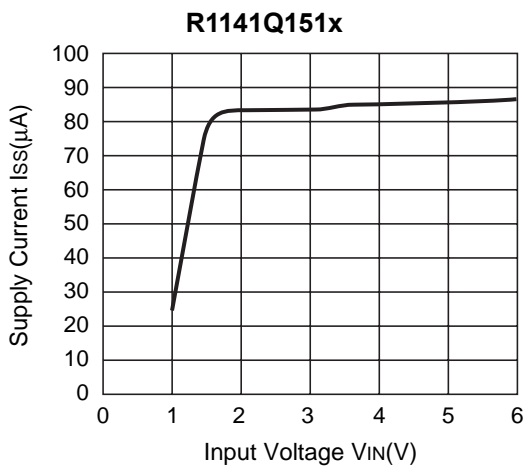

R1141Q

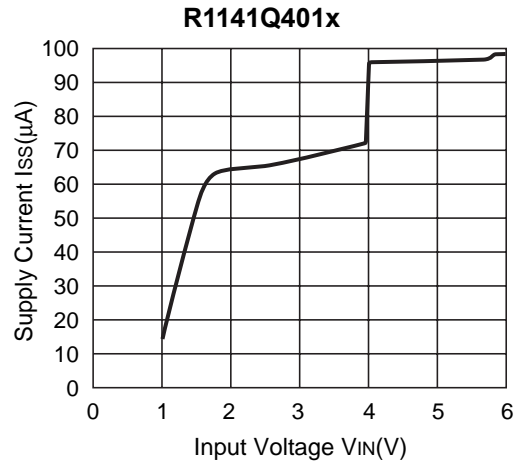
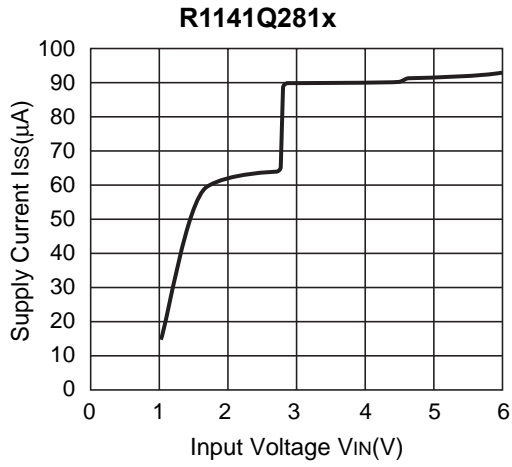

6) Supply Current vs. Temperature

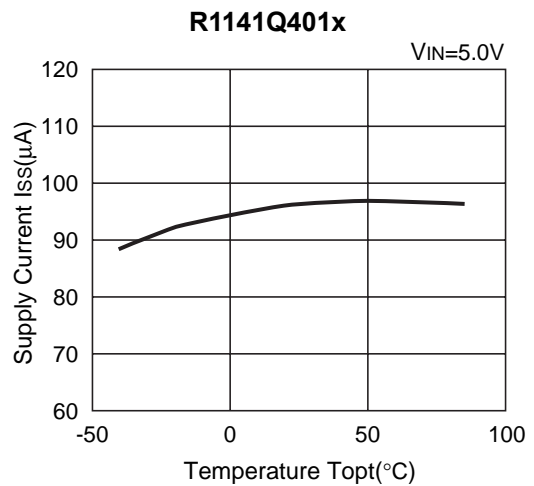
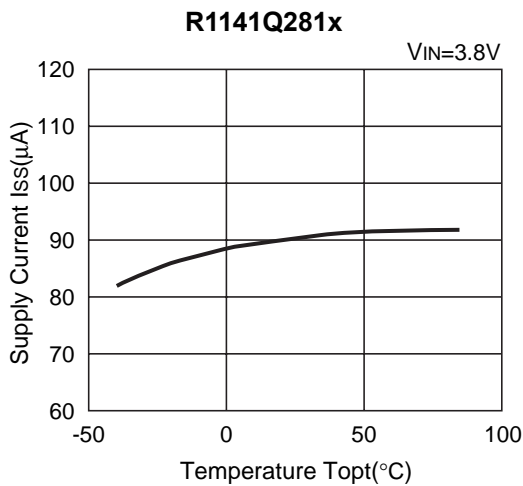
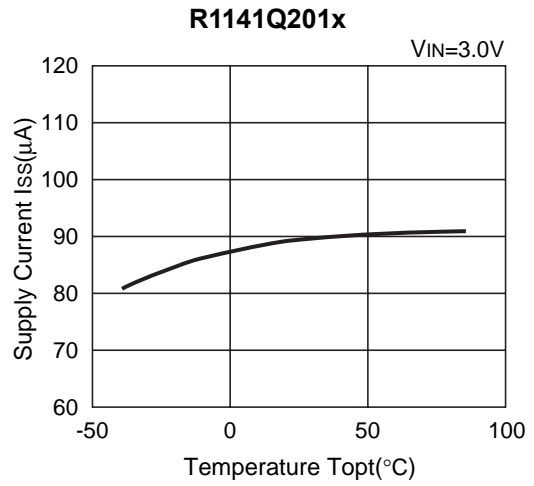
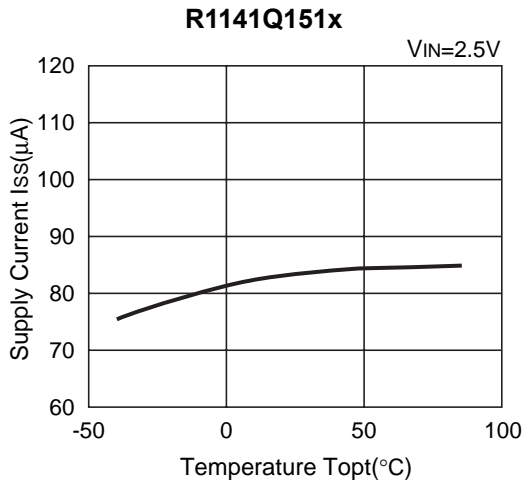

7) Dropout Voltage vs. Set Output Voltage

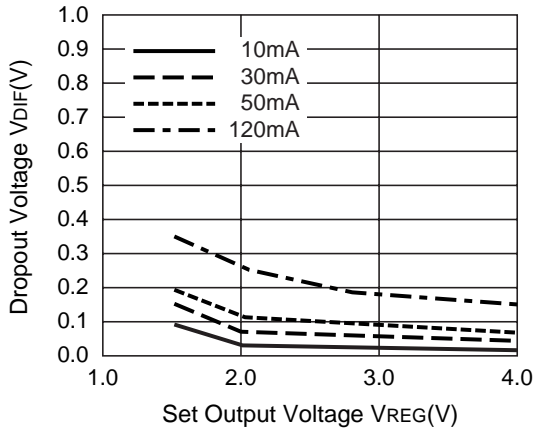

8) Ripple Rejection vs. Frequency

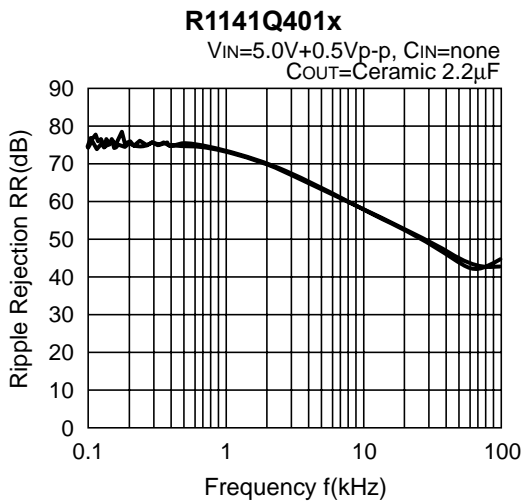
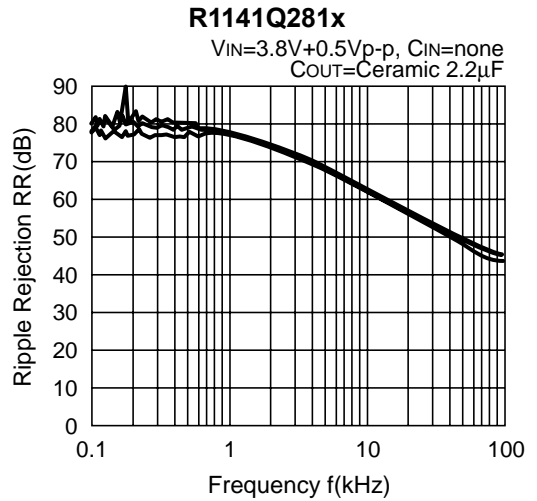
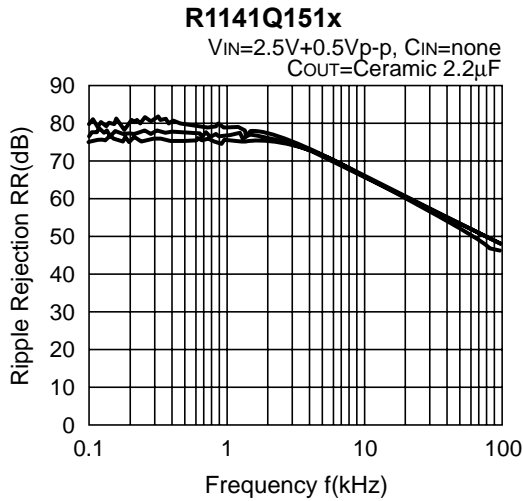

9) Ripple Rejection vs. Input Bias

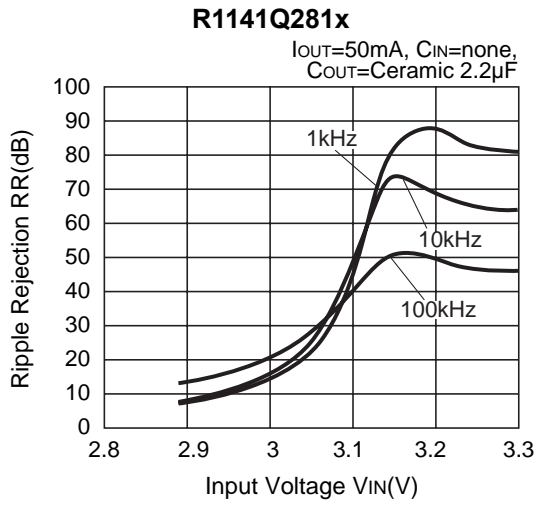
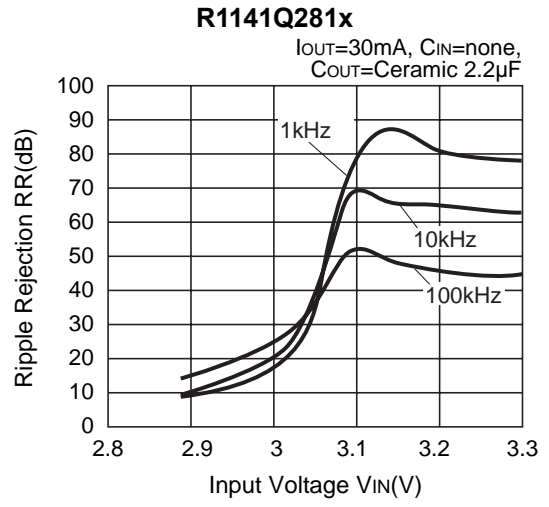
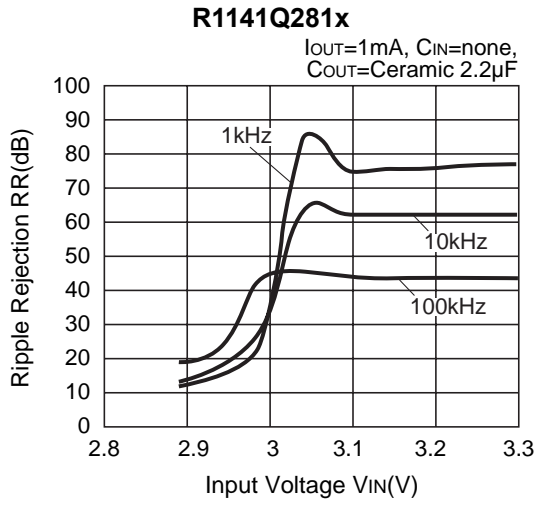

10) Input Transient Response

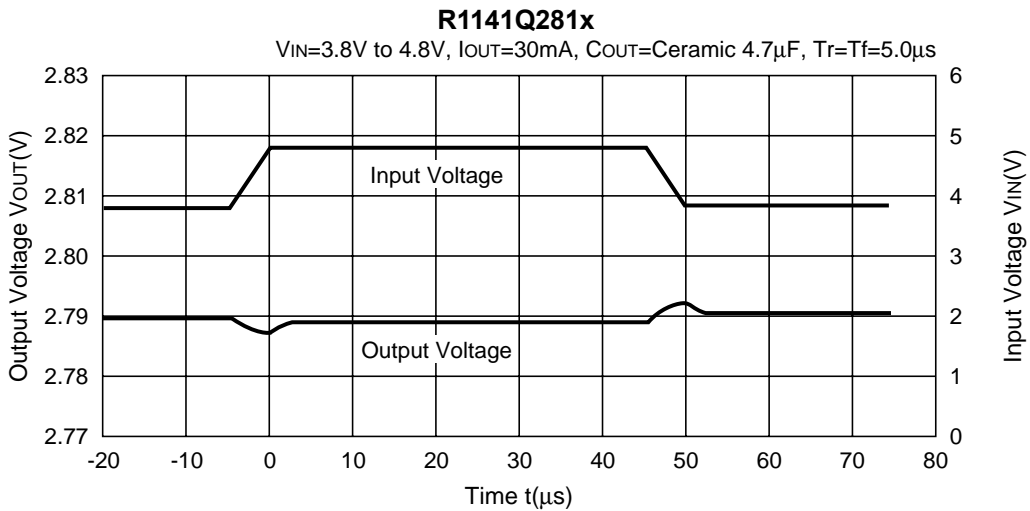
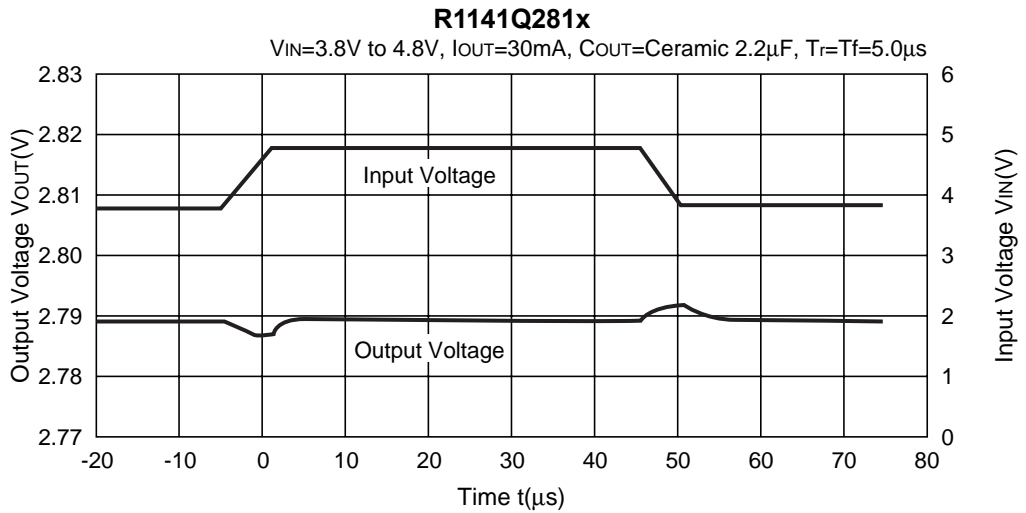
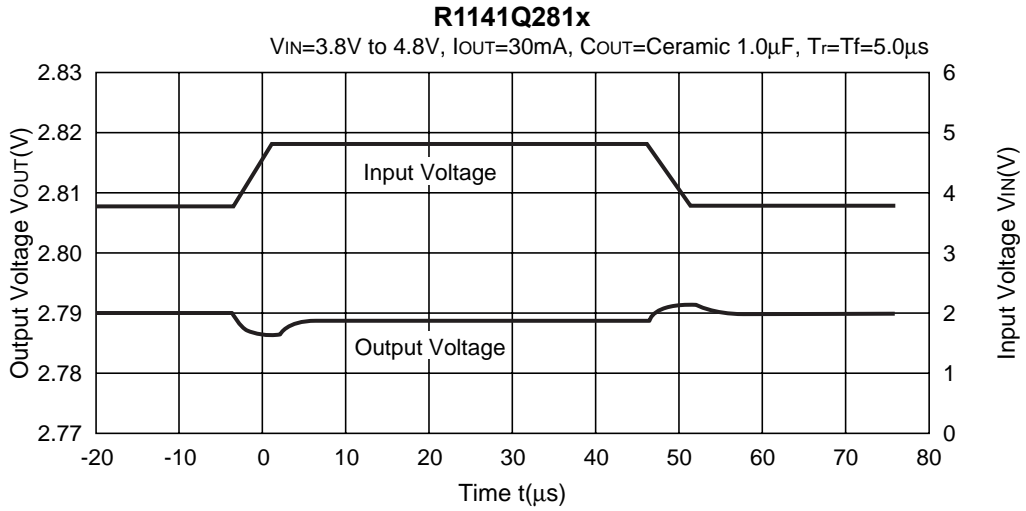

11) Load Transient Response

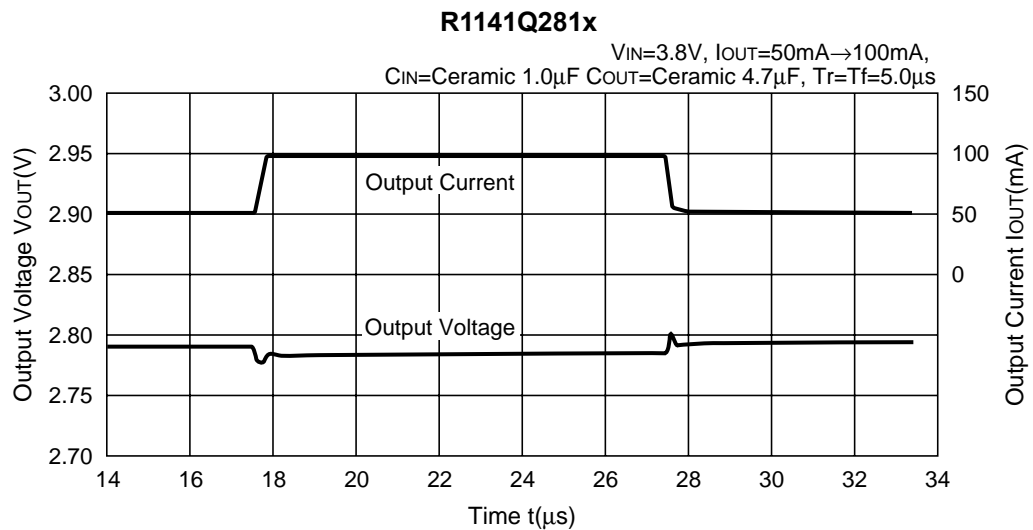
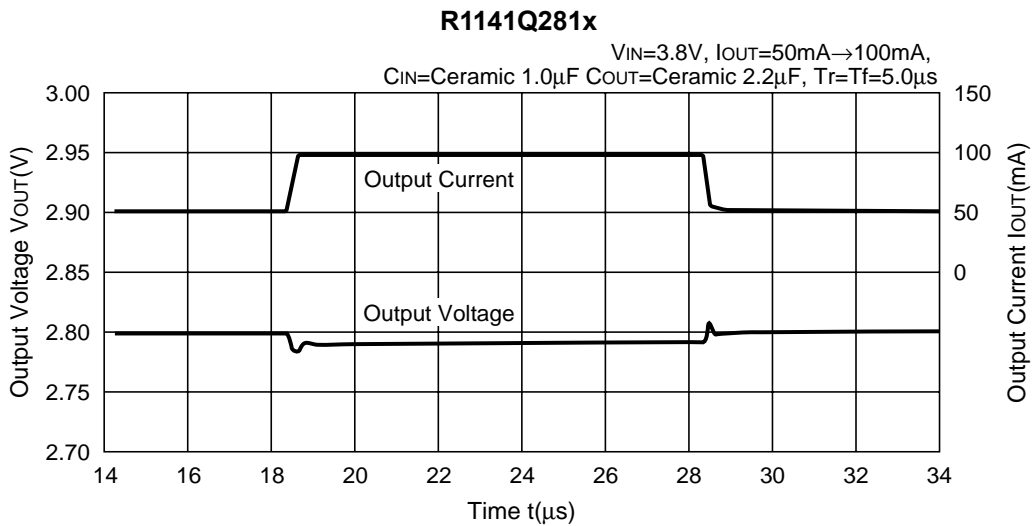
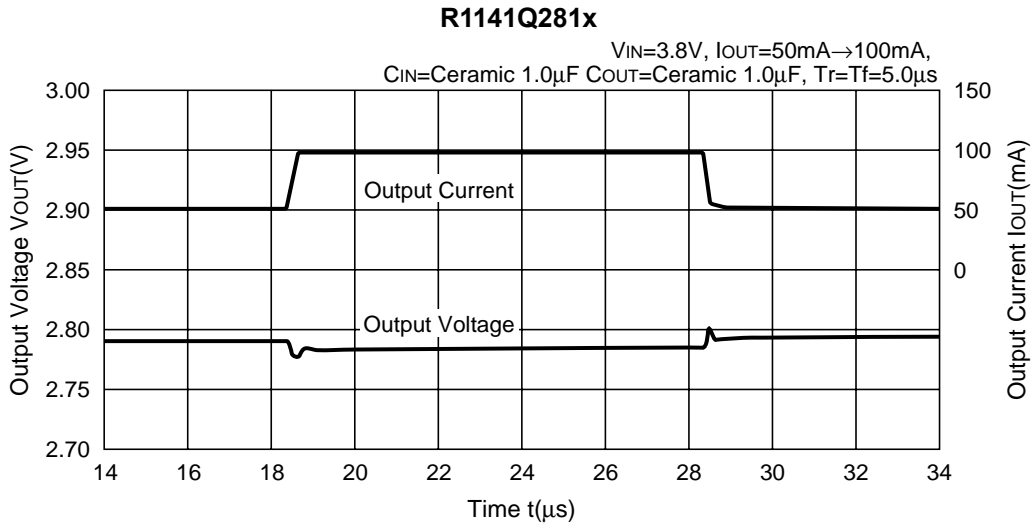

ESR vs. Output Current

When using these ICs, consider the following points:

In these ICs, phase compensation is made for securing stable operation even if the load current is varied. For this purpose, be sure to use a capacitor C_{OUT} with good frequency characteristics and ESR (Equivalent Series Resistance) of which is in the range described as follows:

The relations between I_{OUT} (Output Current) and ESR of Output Capacitor are shown below. The conditions when the white noise level is under $40\mu\text{V}$ (Avg.) are marked as the hatched area in the graph.

<Test conditions>

- (1) $V_{IN}=V_{SET}+1\text{V}$
- (2) Frequency band: 10Hz to 30MHz
- (3) Temperature: 25°C

