

Low Voltage 300mA LDO REGULATOR

NO.EA-116-111027

OUTLINE

The R1131x Series are CMOS-based low voltage regulator ICs with output voltage range from 0.8V to 3.3V. The minimum operating voltage is 1.4V. Each of these voltage regulator ICs consists of a voltage reference unit, an error amplifier, resistors for setting output voltage, a current limit circuit, and a chip enable circuit.

To prevent the destruction by over current, current limit circuit is included. Standby mode realizes ultra small consumption current.

The output voltage of these ICs is internally fixed with high accuracy. Since the packages for these ICs are SOT-23-5, SON-6, and HSON-6, high density mounting of the ICs on boards is possible.

FEATURES

- Supply Current Typ. 80 μ A ($V_{OUT} < 1.8V$)
Typ. 60 μ A ($V_{OUT} \geq 1.8V$)
- Standby Mode Typ. 0.1 μ A
- Dropout Voltage Typ. 0.48V ($I_{OUT}=300mA$ Output Voltage=1.0V Type)
Typ. 0.31V ($I_{OUT}=300mA$ Output Voltage=1.5V Type)
Typ. 0.23V ($I_{OUT}=300mA$ Output Voltage=3.0V Type)
- Ripple Rejection Typ. 65dB ($f=1kHz$)
- Temperature-Drift Coefficient of Output Voltage Typ. $\pm 100ppm/^{\circ}C$
- Line Regulation Typ. 0.01%/V
- Output Voltage Accuracy $\pm 2.0\%$
- Output Voltage Range 0.8V to 3.3V (0.1V steps)
(For other voltages, please refer to MARK INFORMATIONS.)
- Input Voltage Range 1.4V to 6.0V
- Packages SOT-23-5, SON-6, HSON-6
- Built-in fold-back protection circuit Typ. 50mA (Current at short mode)
- External Capacitors $C_{IN}=C_{OUT}=\text{Tantalum } 1.0\mu F$ ($V_{OUT} < 1.0V$)
 $C_{IN}=C_{OUT}=\text{Ceramic } 1.0\mu F$ ($V_{OUT} \geq 1.0V$)

APPLICATIONS

- Precision Voltage References.
- Power source for electrical appliances such as cameras, VCRs and hand-held communication equipment.
- Power source for battery-powered equipment.

BLOCK DIAGRAM

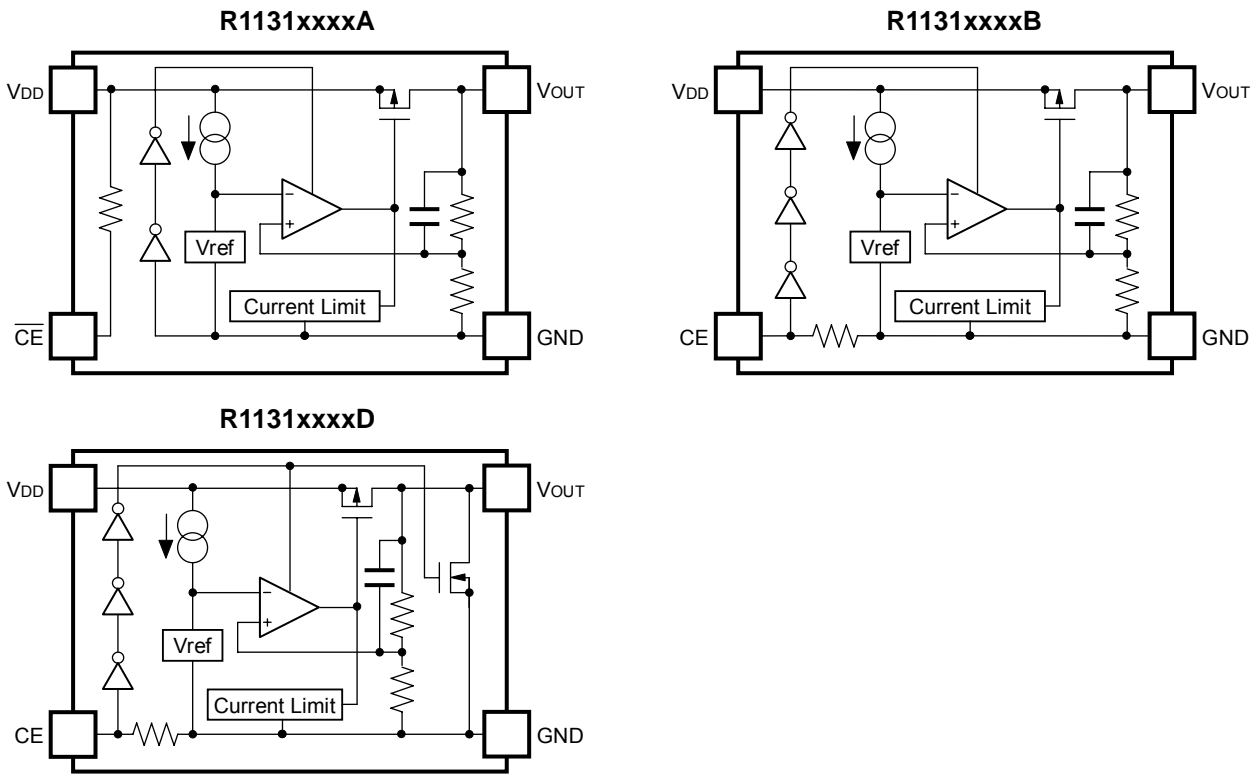

SELECTION GUIDE

The output voltage, CE pin polarity, auto discharge function, package, etc. for the ICs can be selected at the user's request.

Product Name	Package	Quantity per Reel	Pb Free	Halogen Free
R1131Nxx1*-TR-FE	SOT-23-5	3,000 pcs	Yes	Yes
R1131Dxx1*-TR-FE	SON-6	3,000 pcs	Yes	Yes
R1131Dxx2*-TR-FE	HSO-6	3,000 pcs	Yes	Yes

xx: The output voltage can be designated in the range from 0.8V(08) to 3.3V(33) in 0.1V steps.
 (For other voltages, please refer to MARK INFORMATIONS.)

* : CE pin polarity and auto discharge function at off state are options as follows.
 (A) "L" active, without auto discharge function at off state
 (B) "H" active, without auto discharge function at off state
 (D) "H" active, with auto discharge function at off state

PIN CONFIGURATIONS

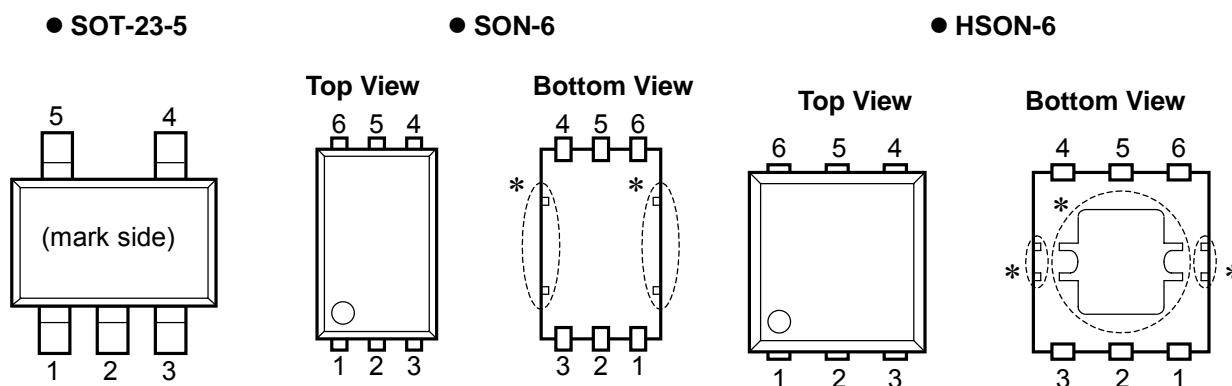

PIN DESCRIPTIONS

● SOT-23-5

Pin No	Symbol	Pin Description
1	V_{DD}	Input Pin
2	GND	Ground Pin
3	\overline{CE} or CE	Chip Enable Pin
4	NC	No Connection
5	V_{OUT}	Output pin

● SON-6, HSON-6

Pin No	Symbol	Pin Description
1	V_{DD}	Input Pin
2	NC	No Connection
3	V_{OUT}	Output pin
4	NC	No Connection
5	GND	Ground Pin
6	\overline{CE} or CE	Chip Enable Pin

*) Tab and tab suspension leads are GND level. (They are connected to the reverse side of this IC.)
 The tab is better to be connected to the GND, but leaving it open is also acceptable.
 The tab suspension leads do not connect to other wires or land patterns.

ABSOLUTE MAXIMUM RATINGS

Symbol	Item	Rating	Unit
V_{IN}	Input Voltage	6.5	V
V_{CE}	Input Voltage(\overline{CE} /CE Pin)	-0.3 to 6.5	V
V_{OUT}	Output Voltage	-0.3 to $V_{IN}+0.3$	V
I_{OUT}	Output Current	350	mA
P_D	Power Dissipation (SOT-23-5)*	420	mW
	Power Dissipation (SON-6)*	500	
	Power Dissipation (HSO-6)*	900	
T_{opt}	Operating Temperature Range	-40 to 85	°C
T_{stg}	Storage Temperature Range	-55 to 125	°C

*) For Power Dissipation please refer to PACKAGE INFORMATION.

ABSOLUTE MAXIMUM RATINGS

Electronic and mechanical stress momentarily exceeded absolute maximum ratings may cause the permanent damages and may degrade the life time and safety for both device and system using the device in the field.

The functional operation at or over these absolute maximum ratings is not assured.

ELECTRICAL CHARACTERISTICS

• R1131xxxxA

$T_{opt}=25^{\circ}\text{C}$

Symbol	Item	Conditions	Min.	Typ.	Max.	Unit	
V_{OUT}	Output Voltage	$V_{IN}=\text{Set } V_{OUT}+1\text{V}$ $1\mu\text{A} \leq I_{OUT} \leq 30\text{mA}$	$V_{OUT} > 1.5\text{V}$	$\times 0.98$		$\times 1.02$	V
			$V_{OUT} \leq 1.5\text{V}$	-30		+30	mV
I_{OUT}	Output Current	$V_{IN}-V_{OUT}=1.0\text{V}$	300			mA	
$\frac{\Delta V_{OUT}}{\Delta I_{OUT}}$	Load Regulation	$V_{IN}=\text{Set } V_{OUT}+1\text{V}$, $1\text{mA} \leq I_{OUT} \leq 300\text{mA}$		40	70	mV	
V_{DIF}	Dropout Voltage	$I_{OUT}=300\text{mA}$	$V_{OUT}=0.8\text{V}$		620	850	mV
			$V_{OUT}=0.9\text{V}$		550	780	
			$1.0\text{V} \leq V_{OUT} < 1.5\text{V}$		480	700	
			$1.5\text{V} \leq V_{OUT} < 2.6\text{V}$		310	450	
			$2.6\text{V} \leq V_{OUT} \leq 3.3\text{V}$		230	350	
I_{SS1}	Supply Current	$V_{IN}=\text{Set } V_{OUT}+1\text{V}$, $V_{OUT} < 1.8\text{V}$		80	111	μA	
		$V_{IN}=\text{Set } V_{OUT}+1\text{V}$, $V_{OUT} \geq 1.8\text{V}$		60	90	μA	
$I_{standby}$	Standby Current	$V_{IN}=V_{CE}=\text{Set } V_{OUT}+1\text{V}$		0.1	1.0	μA	
$\frac{\Delta V_{OUT}}{\Delta V_{IN}}$	Line Regulation	$I_{OUT}=30\text{mA}$ $V_{OUT}+0.5\text{V} \leq V_{IN} \leq 6.0\text{V}$ ($V_{OUT} > 0.9\text{V}$) $1.4\text{V} \leq V_{IN} \leq 6.0\text{V}$ ($V_{OUT} \leq 0.9\text{V}$)		0.01	0.15	%/V	
RR	Ripple Rejection	$f=1\text{kHz}$, Ripple 0.2Vp-p $V_{IN}=\text{Set } V_{OUT}+1\text{V}$, $I_{OUT}=30\text{mA}$		65		dB	
V_{IN}	Input Voltage		1.4		6.0	V	
$\frac{\Delta V_{OUT}}{\Delta T_{opt}}$	Output Voltage Temperature Coefficient	$I_{OUT}=30\text{mA}$ $-40^{\circ}\text{C} \leq T_{opt} \leq 85^{\circ}\text{C}$		± 100		ppm/ $^{\circ}\text{C}$	
I_{SC}	Short Current Limit	$V_{OUT}=0\text{V}$		50		mA	
R_{PU}	\overline{CE} Pull-up Resistance		1.87	5.0	12.0	$\text{M}\Omega$	
V_{CEH}	\overline{CE} Input Voltage "H"		1.0		6.0	V	
V_{CEL}	\overline{CE} Input Voltage "L"		0		0.3	V	
en	Output Noise	$\text{BW}=10\text{Hz to } 100\text{kHz}$		30		μVrms	

RECOMMENDED OPERATING CONDITIONS (ELECTRICAL CHARACTERISTICS)

All of electronic equipment should be designed that the mounted semiconductor devices operate within the recommended operating conditions. The semiconductor devices cannot operate normally over the recommended operating conditions, even if when they are used over such conditions by momentary electronic noise or surge. And the semiconductor devices may receive serious damage when they continue to operate over the recommended operating conditions.

R1131x

• R1131xxxxB/D

T_{opt}=25°C

Symbol	Item	Conditions	Min.	Typ.	Max.	Unit	
V _{OUT}	Output Voltage	V _{IN} =Set V _{OUT} +1V 1μA ≤ I _{OUT} ≤ 30mA	V _{OUT} > 1.5V	×0.98	×1.02	V	
			V _{OUT} ≤ 1.5V	-30	+30	mV	
I _{OUT}	Output Current	V _{IN} -V _{OUT} =1.0V	300			mA	
ΔV _{OUT} / ΔI _{OUT}	Load Regulation	V _{IN} =Set V _{OUT} +1V 1mA ≤ I _{OUT} ≤ 300mA		40	70	mV	
V _{DIF}	Dropout Voltage	I _{OUT} =300mA	V _{OUT} =0.8V		620	850	mV
			V _{OUT} =0.9V		550	780	
			1.0V ≤ V _{OUT} < 1.5V		480	700	
			1.5V ≤ V _{OUT} < 2.6V		310	450	
			2.6V ≤ V _{OUT} ≤ 3.3V		230	350	
I _{SS1}	Supply Current	V _{IN} =Set V _{OUT} +1V, V _{OUT} < 1.8V		80	111	μA	
		V _{IN} =Set V _{OUT} +1V, V _{OUT} ≥ 1.8V		60	90	μA	
I _{standby}	Standby Current	V _{IN} =Set V _{OUT} +1V, V _{CE} =GND		0.1	1.0	μA	
ΔV _{OUT} / ΔV _{IN}	Line Regulation	I _{OUT} =30mA V _{OUT} +0.5V ≤ V _{IN} ≤ 6.0V (V _{OUT} > 0.9V) 1.4V ≤ V _{IN} ≤ 6.0V (V _{OUT} ≤ 0.9V)		0.01	0.15	%/V	
RR	Ripple Rejection	f=1kHz, Ripple 0.2Vp-p V _{IN} =Set V _{OUT} +1V, I _{OUT} =30mA		65		dB	
V _{IN}	Input Voltage		1.4		6.0	V	
ΔV _{OUT} / ΔT _{opt}	Output Voltage Temperature Coefficient	I _{OUT} =30mA -40°C ≤ T _{opt} ≤ 85°C		±100		ppm /°C	
I _{SC}	Short Current Limit	V _{OUT} =0V		50		mA	
R _{PD}	CE Pull-down Resistance		1.87	5.0	12.0	MΩ	
V _{CEH}	CE Input Voltage "H"		1.0		6.0	V	
V _{CEL}	CE Input Voltage "L"		0		0.3	V	
en	Output Noise	BW=10Hz to 100kHz		30		μVrms	
R _{LOW}	Nch On Resistance for auto discharge (D version only)	V _{CE} =0V		60		Ω	

RECOMMENDED OPERATING CONDITIONS (ELECTRICAL CHARACTERISTICS)

All of electronic equipment should be designed that the mounted semiconductor devices operate within the recommended operating conditions. The semiconductor devices cannot operate normally over the recommended operating conditions, even if when they are used over such conditions by momentary electronic noise or surge. And the semiconductor devices may receive serious damage when they continue to operate over the recommended operating conditions.

TYPICAL APPLICATION

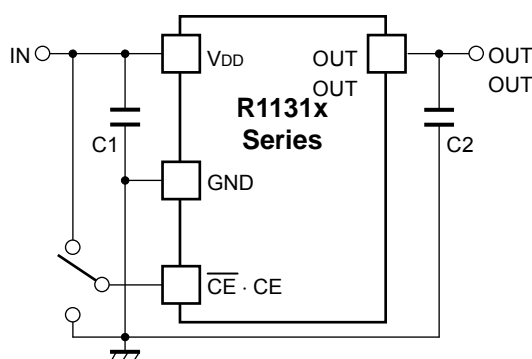

<External Components examples>

- C2 1.0 μ F CM05X5R105K06AB (Kyocera)
- C2 1.0 μ F C1005JBOJ105K (TDK)
- C2 1.0 μ F GRM155B30J105KE18B (Murata)

Output Capacitor; 1.0 μ F or more capacity ceramic Type

(If $V_{OUT} < 1.0V$, Tantalum Type is recommended)

Input Capacitor, 1.0 μ F or more capacity ceramic Type

TECHNICAL NOTES

When using these ICs, consider the following points:

Phase Compensation

In these ICs, phase compensation is made for securing stable operation even if the load current is varied. For this purpose, be sure to use a 1.0 μ F or more capacitor C_{OUT} with good frequency characteristics and ESR (Equivalent Series Resistance).

(Note: If a tantalum capacitor is connected to the Output pin for phase compensation, if the ESR value of the capacitor is too large, the operation might be unstable. Because of this, test these ICs with as same external components as ones to be used on the PCB.)

Chip capacitor characteristics of Bias dependence and Temperature characteristics may vary depending on its size, manufacturer, and part number.

PCB Layout

Make V_{DD} and GND lines sufficient. If their impedance is high, pick-up the noise or unstable operation may result. Connect a capacitor with as much as 1.0 μ F capacitor between V_{DD} and GND pin as close as possible.

Set external components, especially the output capacitor, as close as possible to the ICs, and make wiring as short as possible.

TEST CIRCUIT

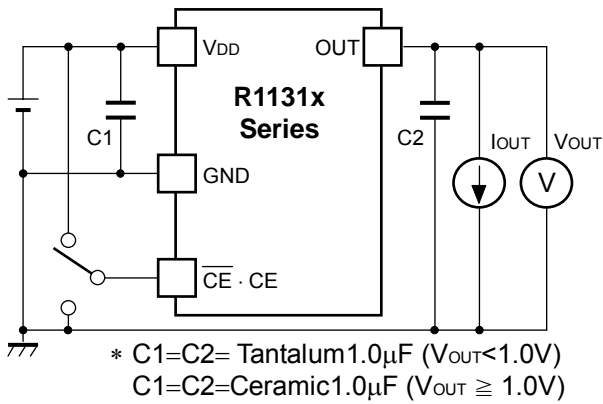

Standard Test Circuit

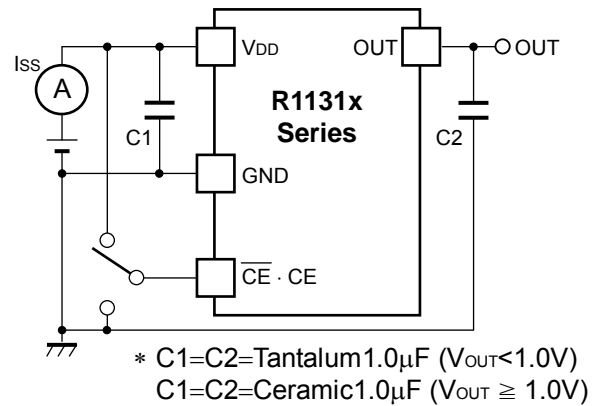

Supply Current Test Circuit

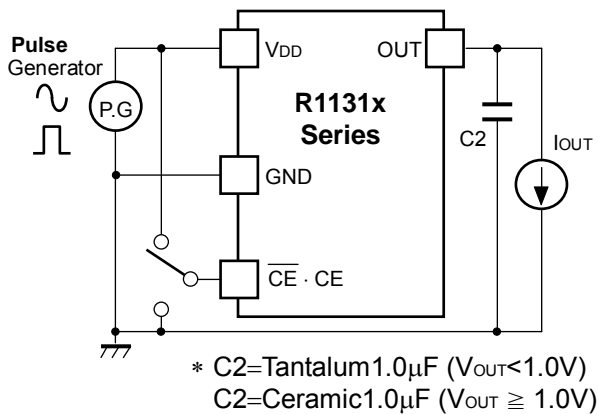

Ripple Rejection, Line Transient Response Test Circuit

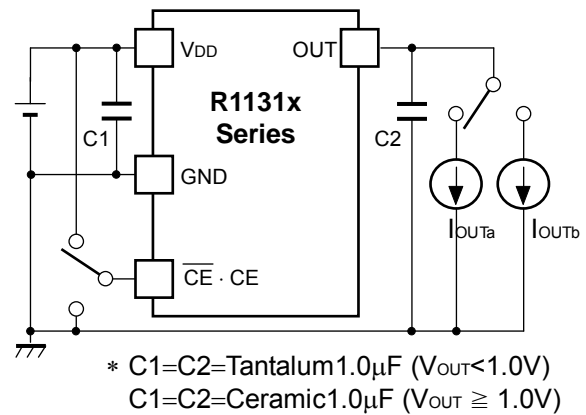

Load Transient Response Test Circuit

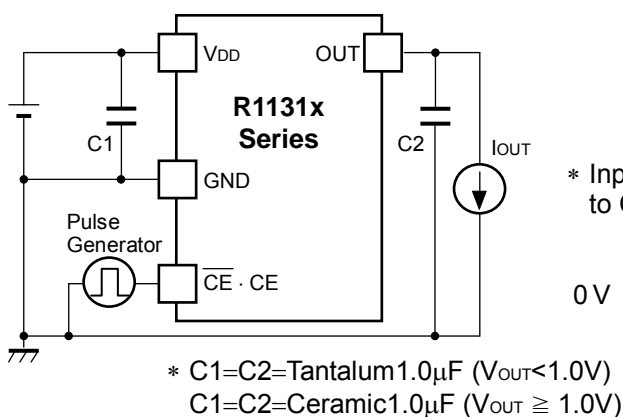

Turn on Speed with CE pin Test Circuit

* Input signal waveform to CE pin is shown below.

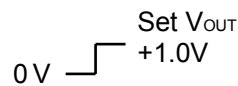

TYPICAL CHARACTERISTICS

1) Output Voltage vs. Output Current

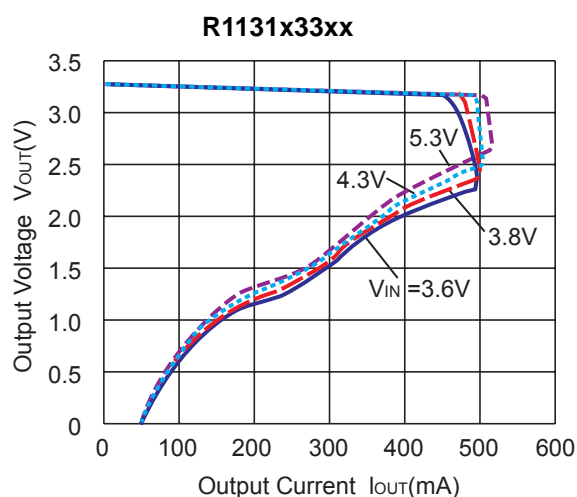
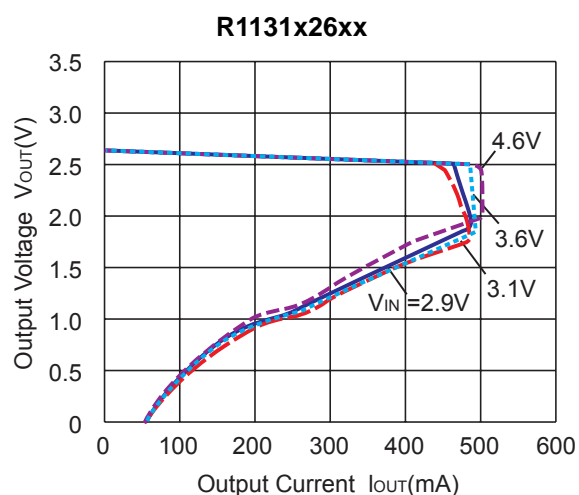
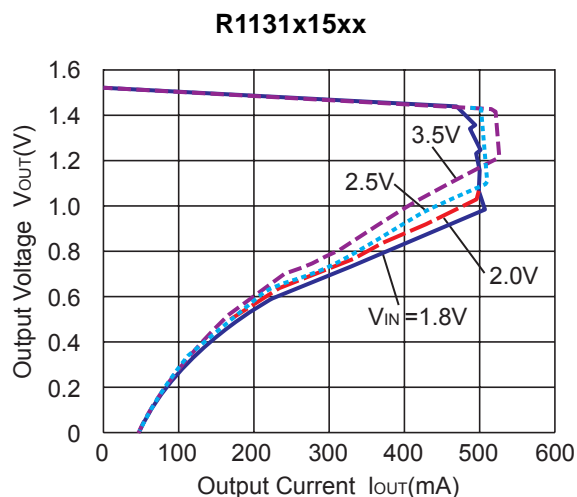
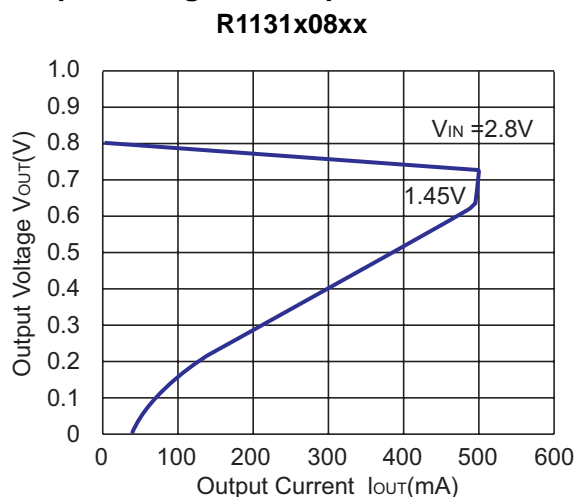

2) Output Voltage vs. Input Voltage

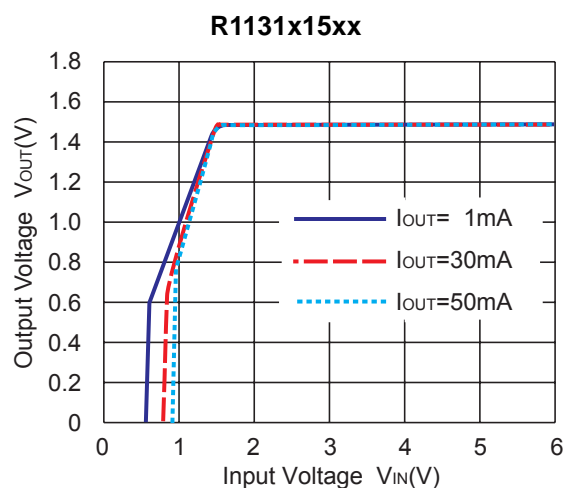
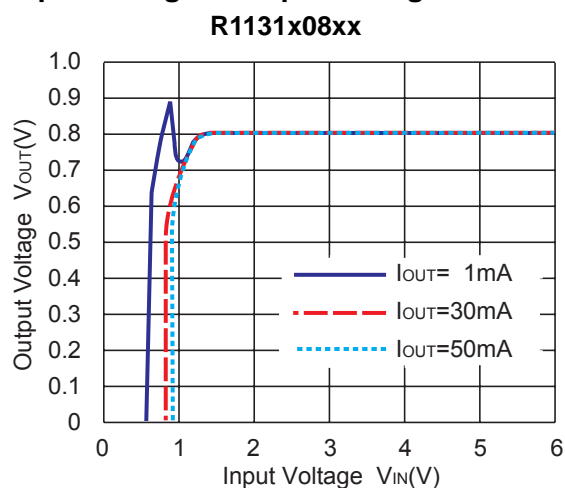

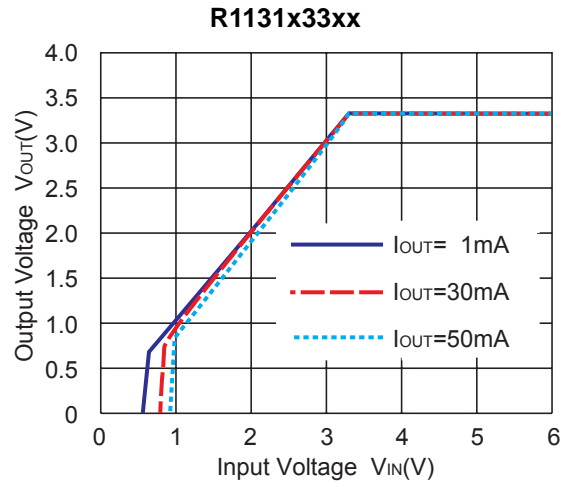
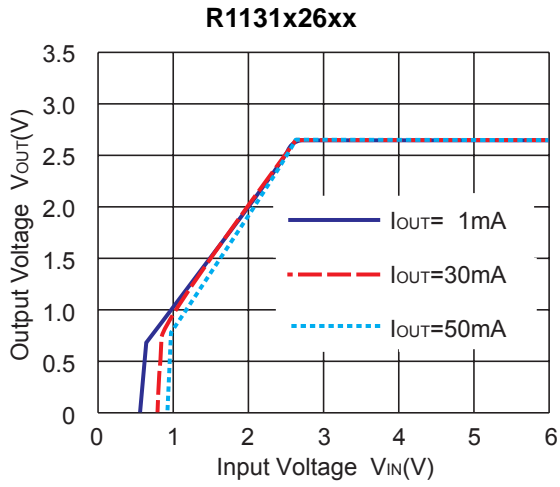

3) Supply Current vs. Input Voltage

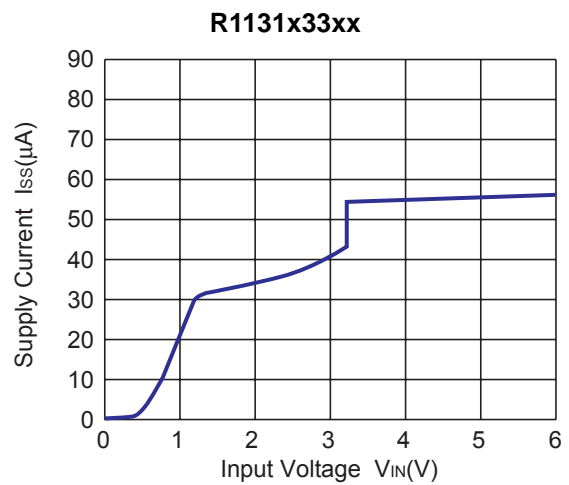
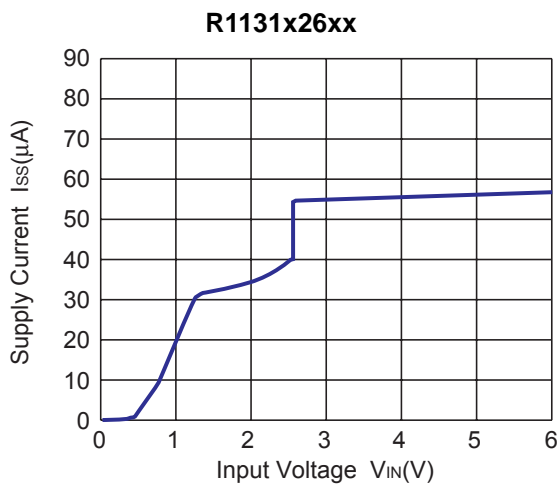
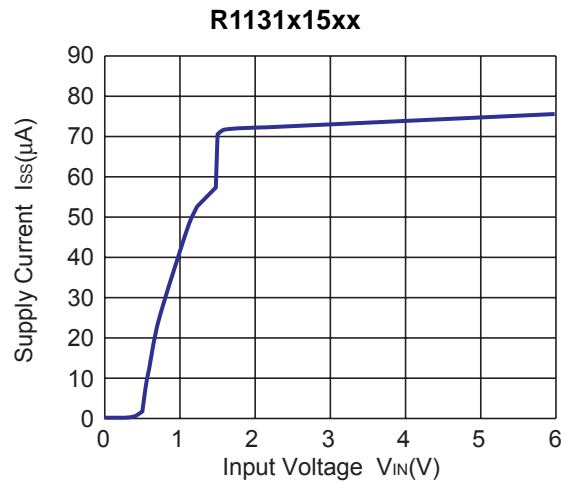
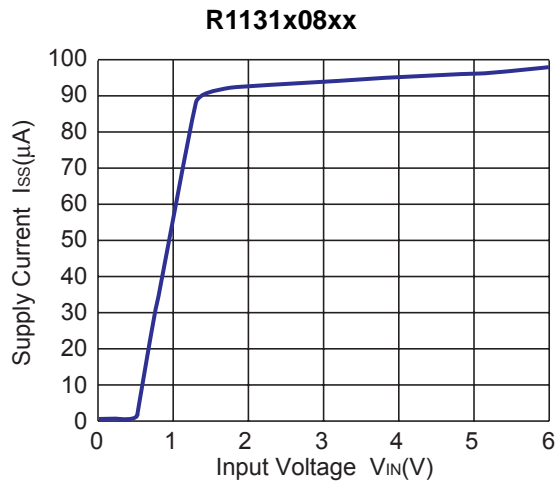

4) Output Voltage vs. Temperature

R1131x08xx

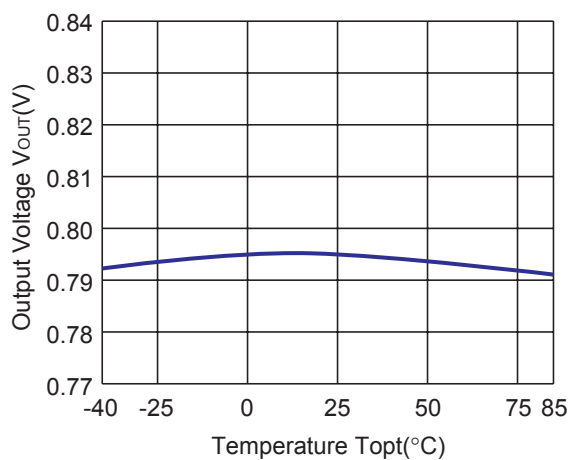

R1131x15xx

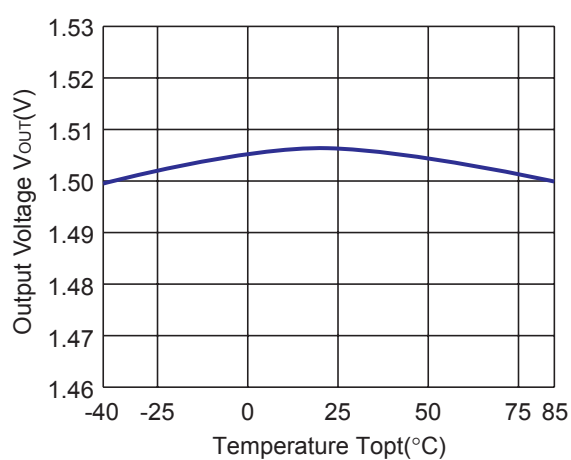

R1131x26xx

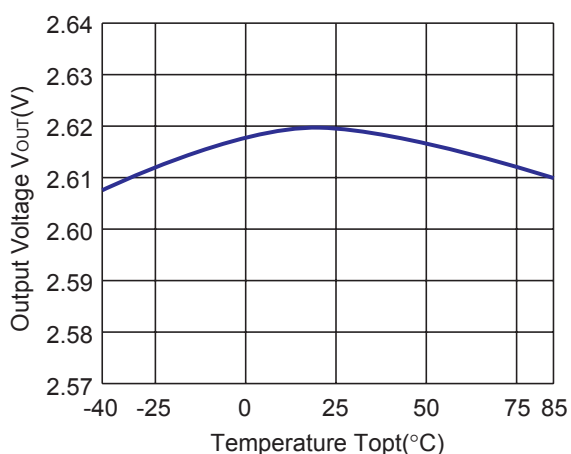

R1131x33xx

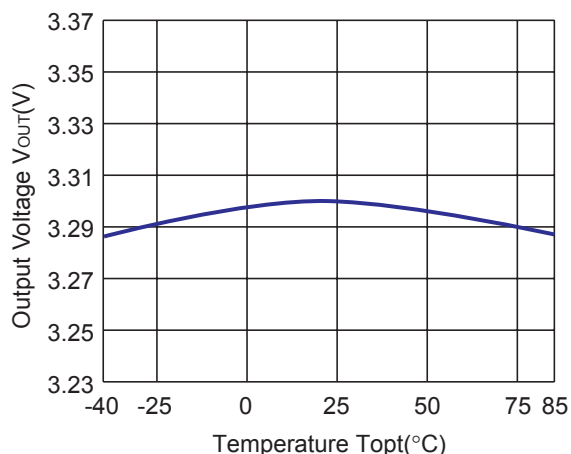

5) Supply Current vs. Temperature

R1131x08xx

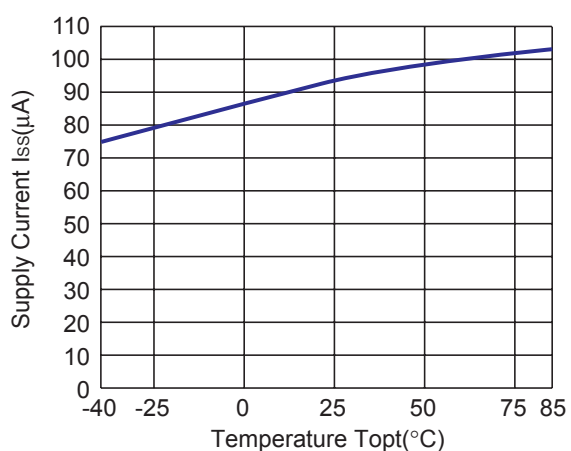

R1131x15xx

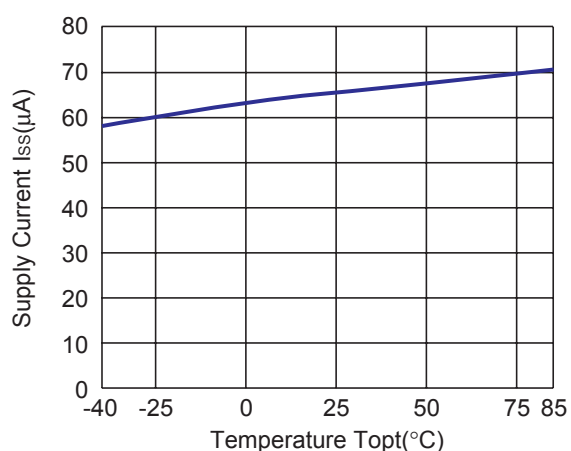

R1131x26xx

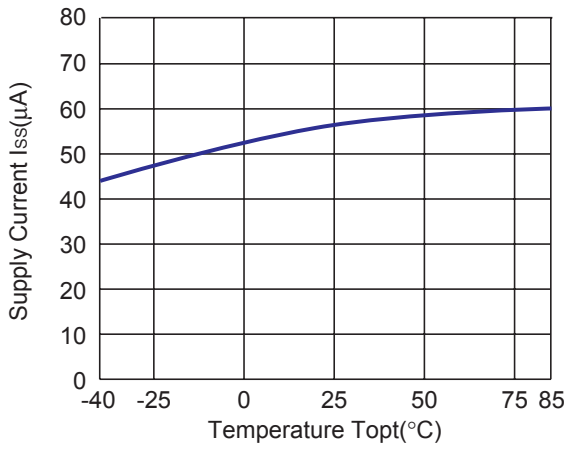

R1131x33xx

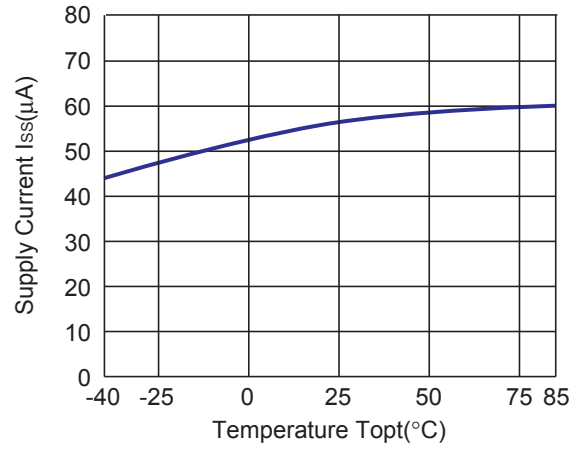

6) Dropout Voltage vs. Output Current

R1131x08xx

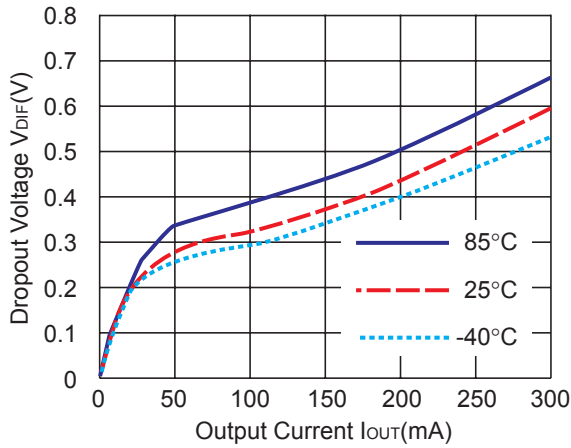

R1131x09xx

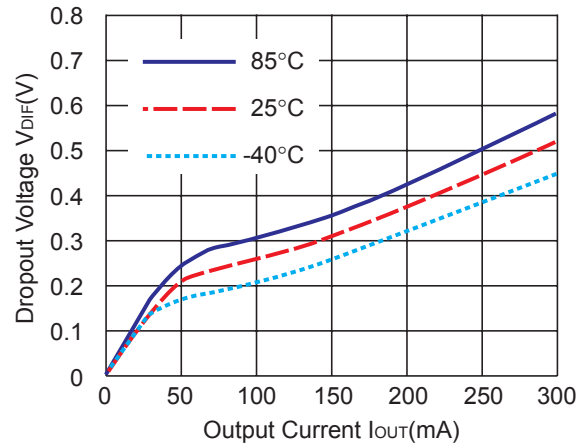

R1131x10xx

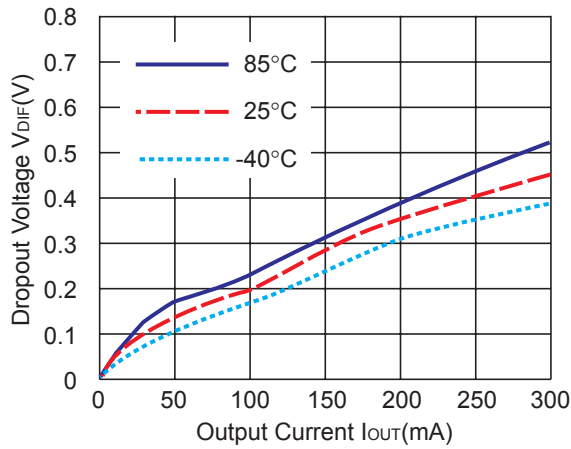

R1131x15xx

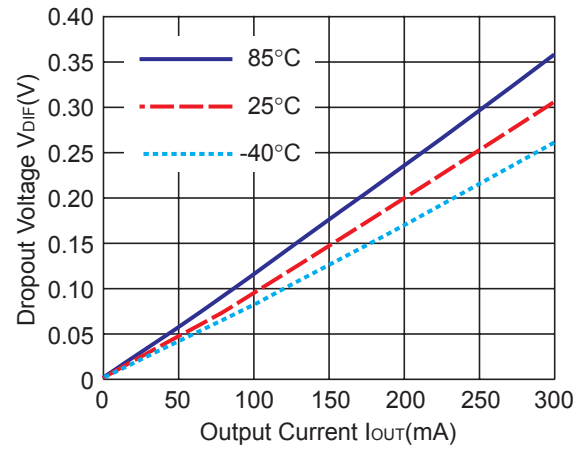

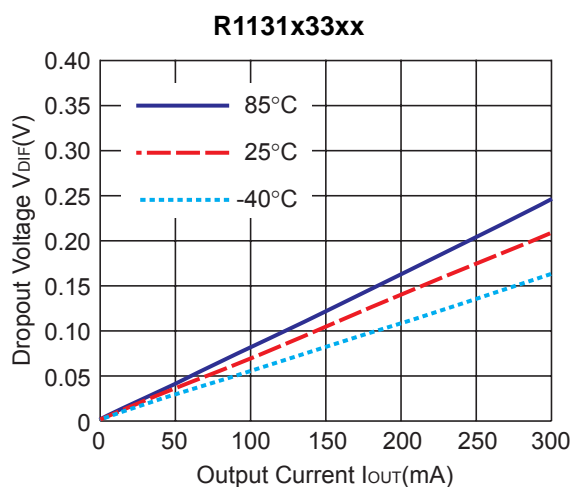
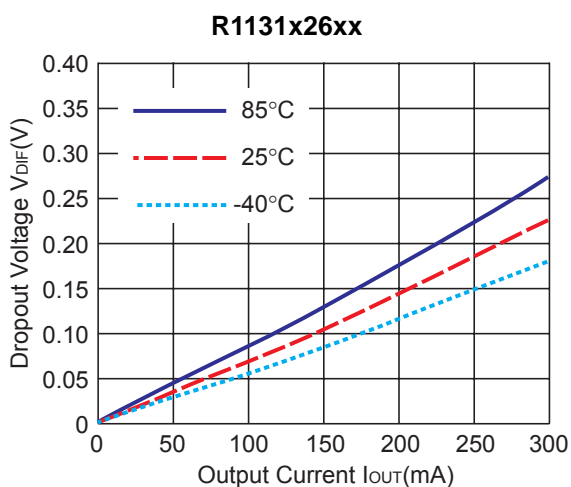

7) Dropout Voltage vs. Set Output Voltage (T_{opt}=25°C)

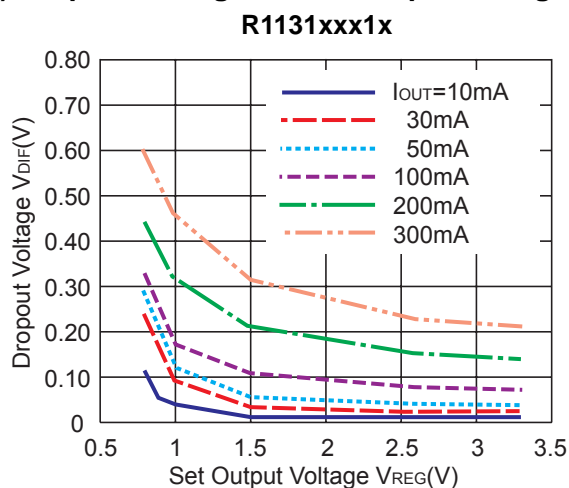

8) Ripple Rejection vs. Input Bias (T_{opt}=25°C C_{IN}=none, C_{OUT}=Ceramic 1.0μF Ripple 0.2V_{P-P})

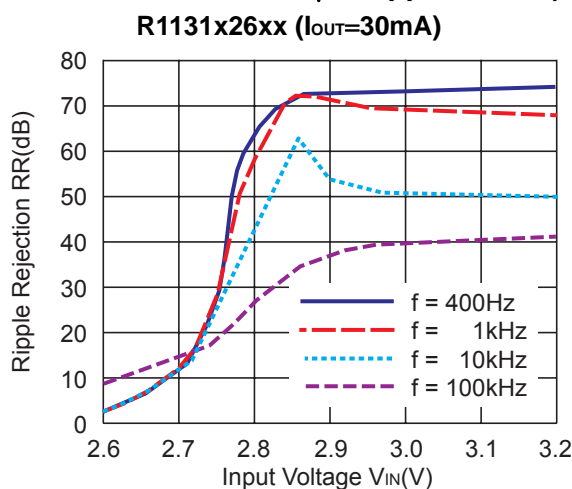
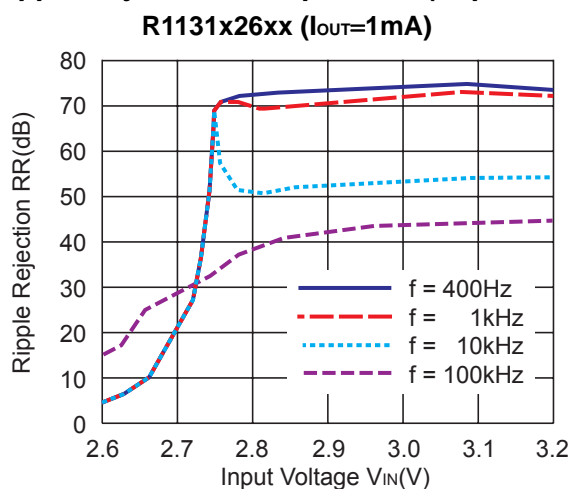

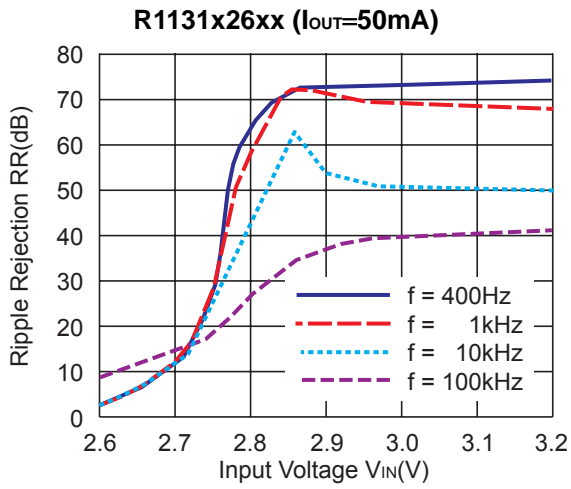

9) Ripple Rejection vs. Frequency (C_{IN}=none)

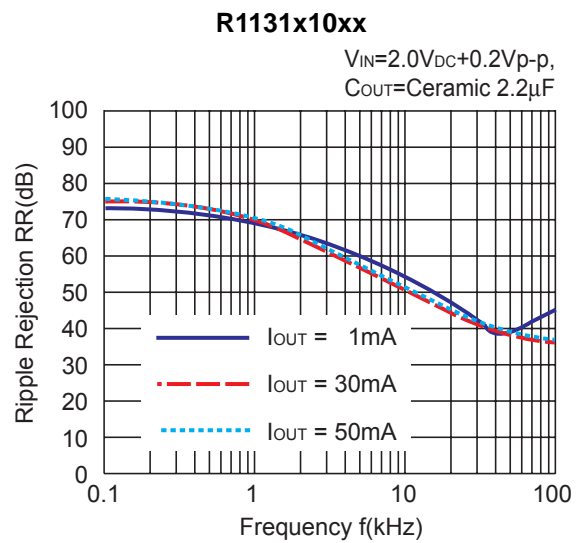
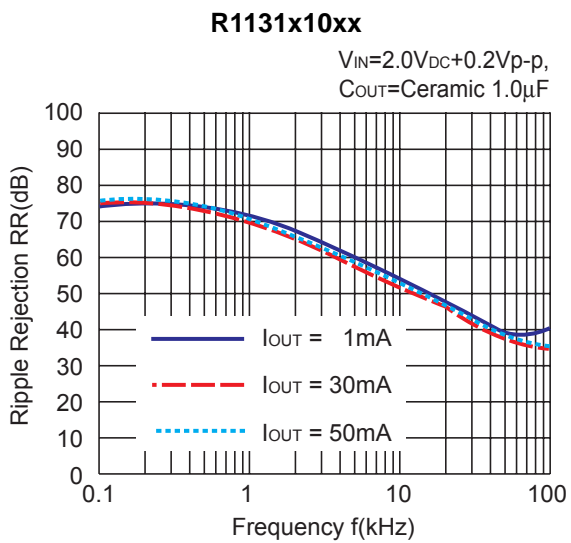
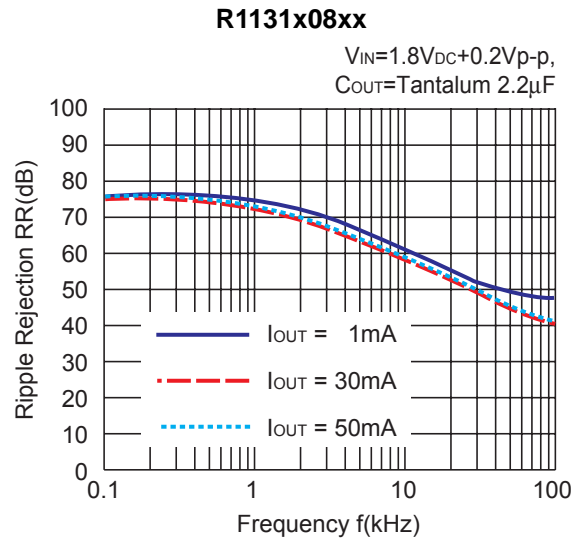
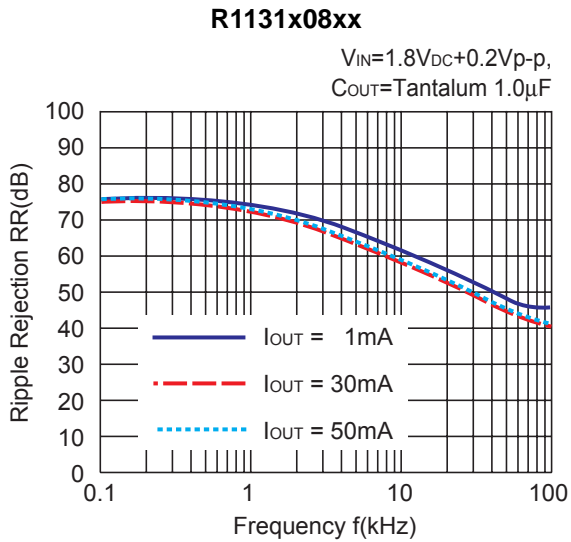

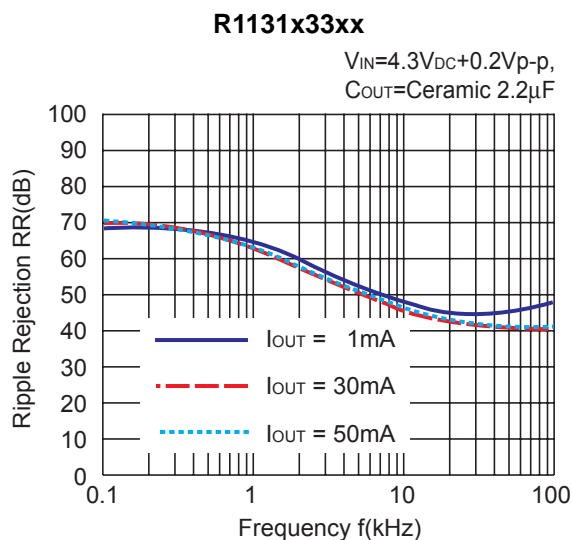
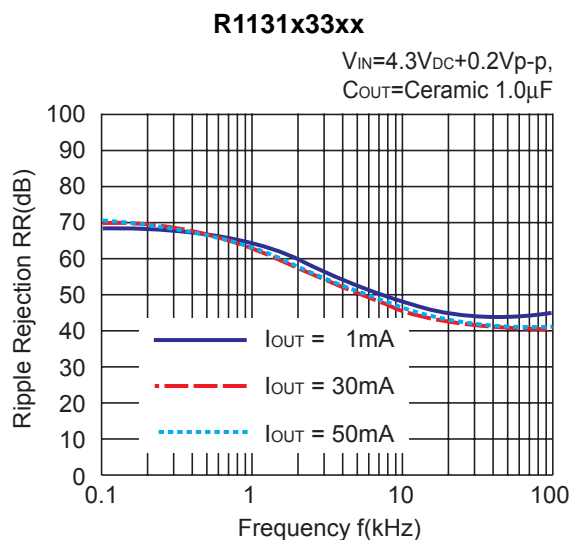
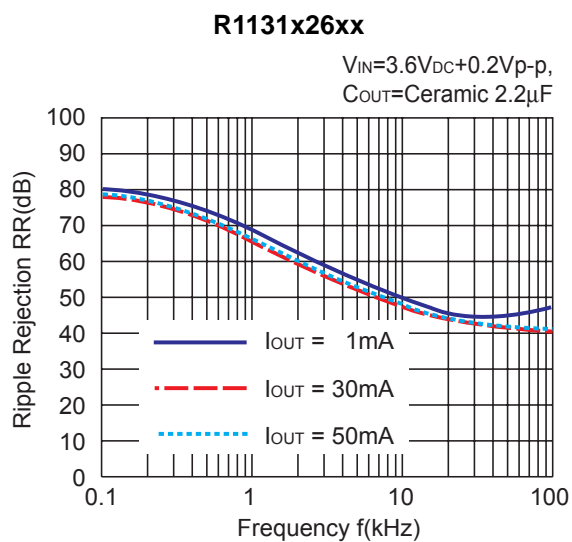
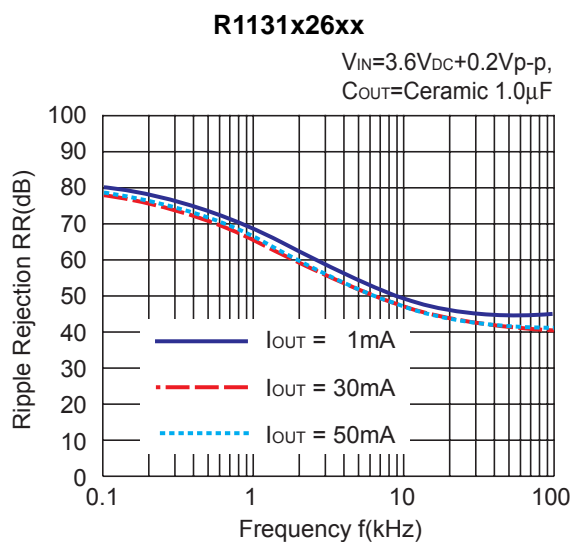
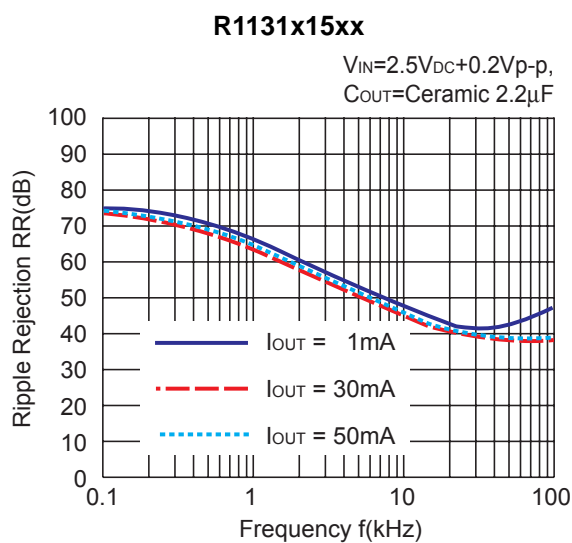
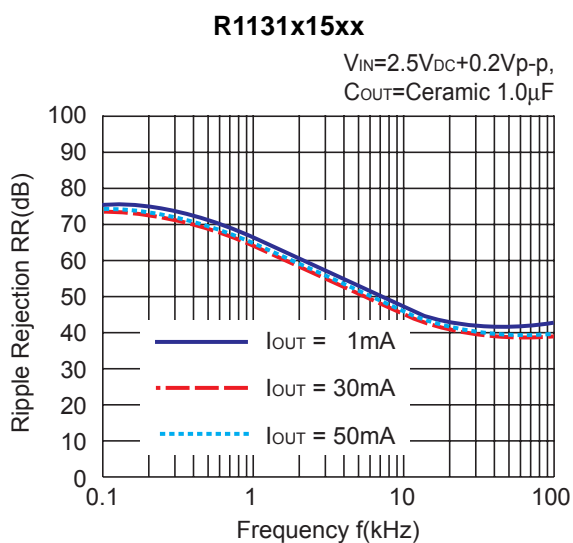

10) Input Transient Response ($C_{IN}=none, tr=tf=5\mu s$)

R1131x08xx

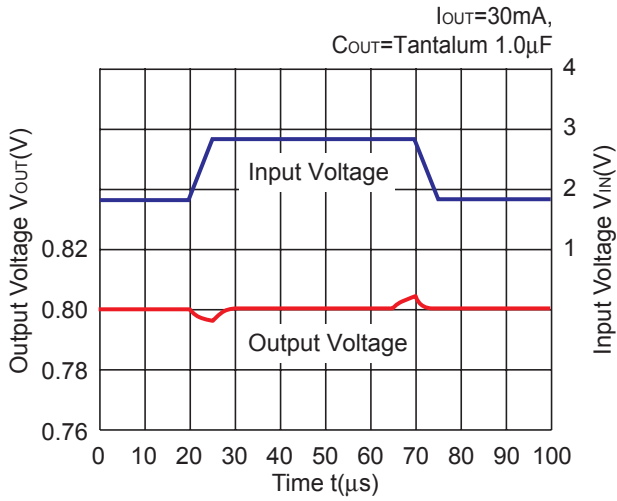

R1131x10x

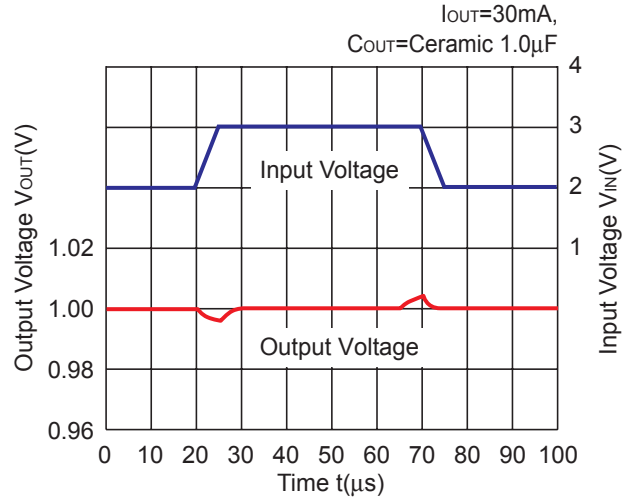

R1131x26xx

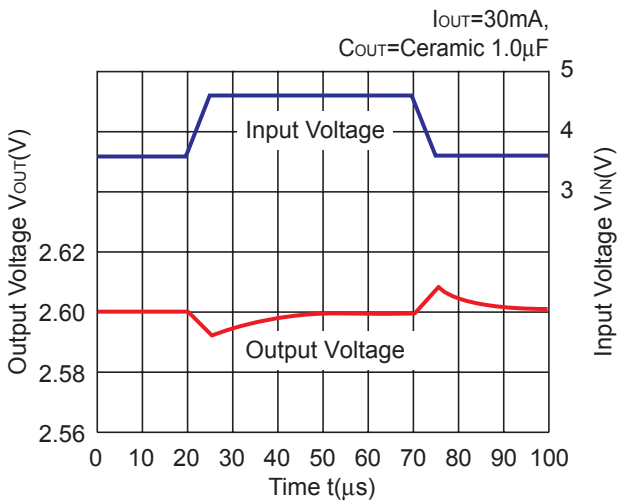

11) Load Transient Response ($tr=tf=0.5\mu s$)

R1131x08xx

$V_{IN}=1.8V\ C_{IN}=Tantalum\ 1.0\mu F,$
 $C_{OUT}=Tantalum\ 1.0\mu F$

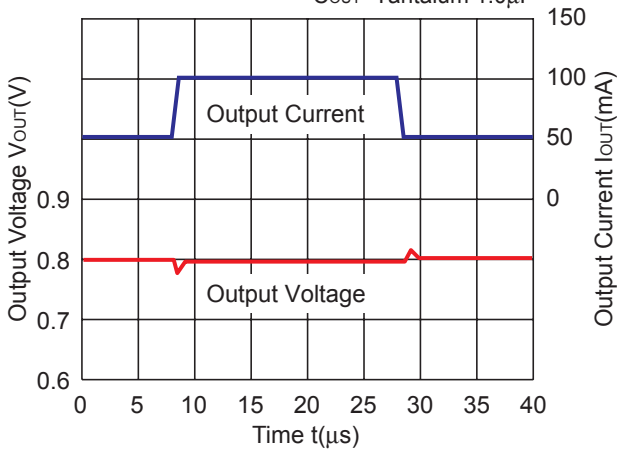

R1131x08xx

$V_{IN}=1.8V\ C_{IN}=Tantalum\ 1.0\mu F,$
 $C_{OUT}=Tantalum\ 2.2\mu F$

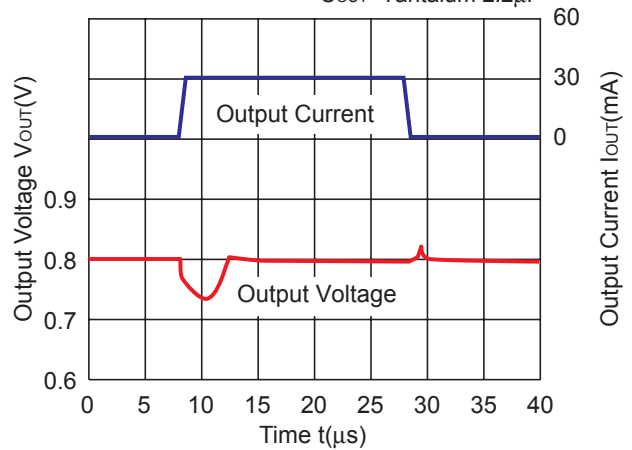

R1131x10xx

$V_{IN}=2.0V$ $C_{IN}=\text{Ceramic } 1.0\mu F$,
 $C_{OUT}=\text{Ceramic } 1.0\mu F$

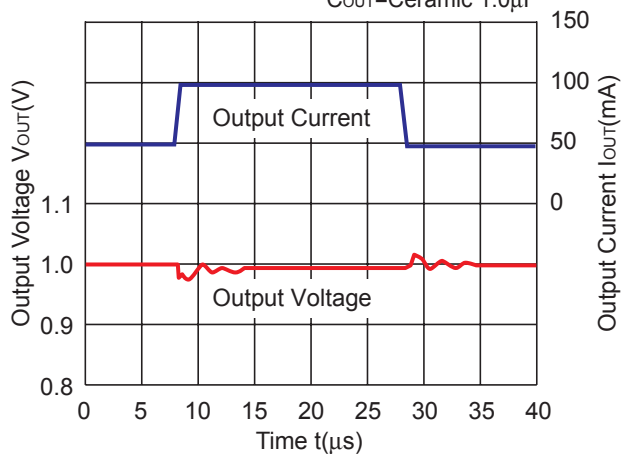
**R1131x10xx**

$V_{IN}=2.0V$ $C_{IN}=\text{Ceramic } 1.0\mu F$,
 $C_{OUT}=\text{Ceramic } 2.2\mu F$

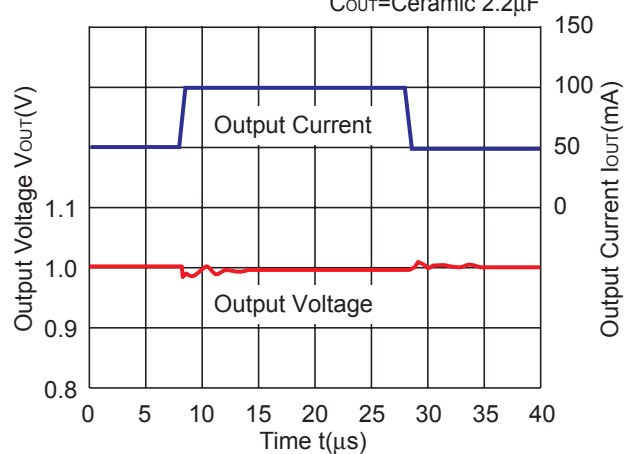
**R1131x10xx**

$V_{IN}=2.0V$ $C_{IN}=\text{Ceramic } 1.0\mu F$,
 $C_{OUT}=\text{Ceramic } 1.0\mu F$

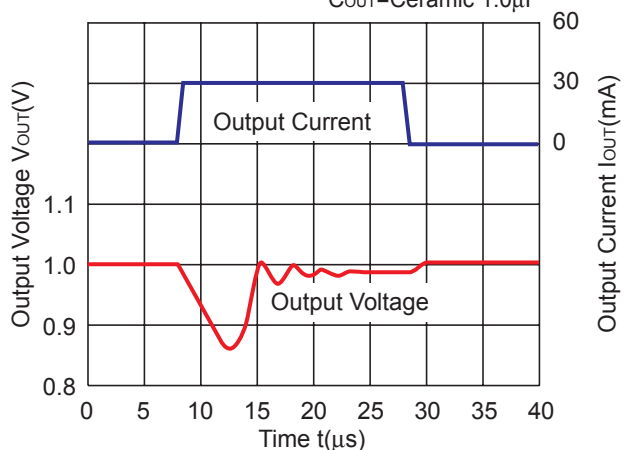
**R1131x10xx**

$V_{IN}=2.0V$ $C_{IN}=\text{Ceramic } 1.0\mu F$,
 $C_{OUT}=\text{Ceramic } 2.2\mu F$

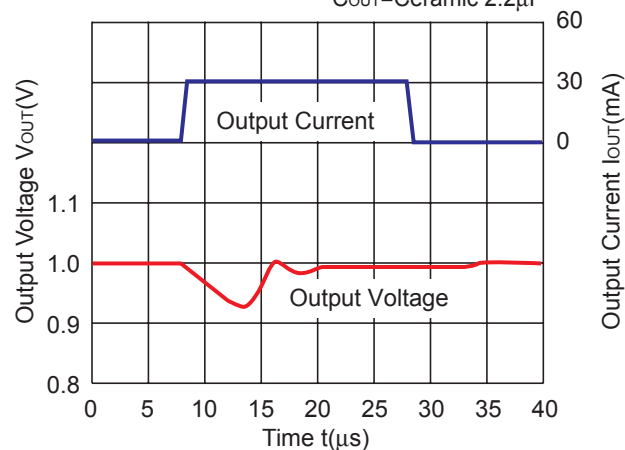
**R1131x26xx**

$V_{IN}=3.6V$ $C_{IN}=\text{Ceramic } 1.0\mu F$,
 $C_{OUT}=\text{Ceramic } 1.0\mu F$

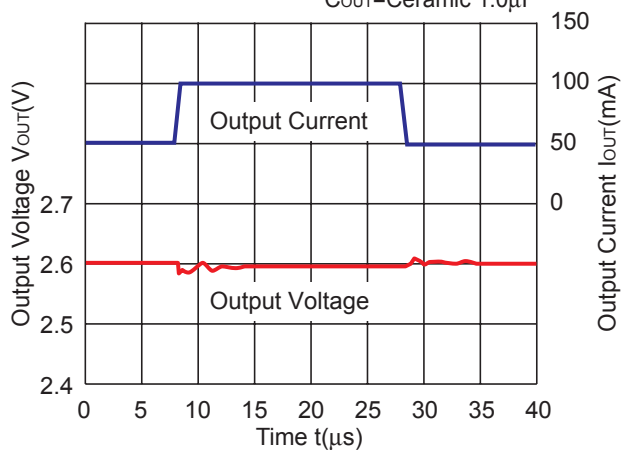
**R1131x26xx**

$V_{IN}=3.6V$ $C_{IN}=\text{Ceramic } 1.0\mu F$,
 $C_{OUT}=\text{Ceramic } 2.2\mu F$

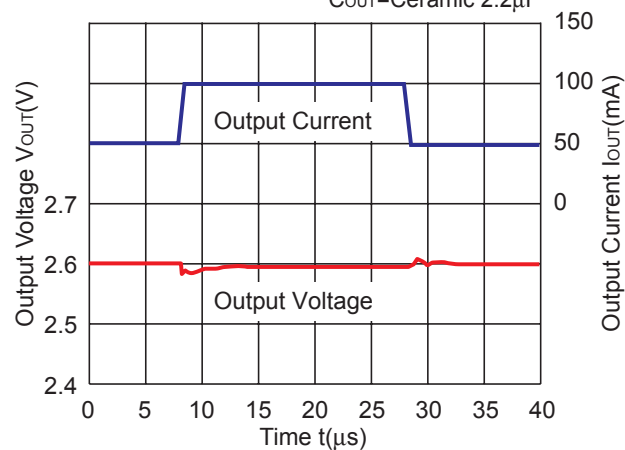

R1131x26xx

$V_{IN}=3.6V$ $C_{IN}=\text{Ceramic } 1.0\mu F$,
 $C_{OUT}=\text{Ceramic } 1.0\mu F$

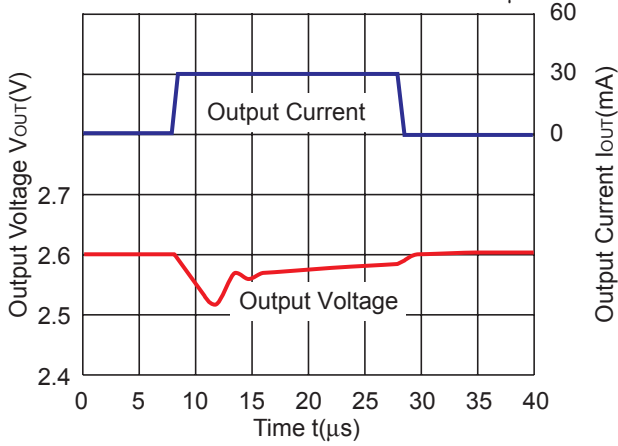

R1131x26xx

$V_{IN}=3.6V$ $C_{IN}=\text{Ceramic } 1.0\mu F$,
 $C_{OUT}=\text{Ceramic } 2.2\mu F$

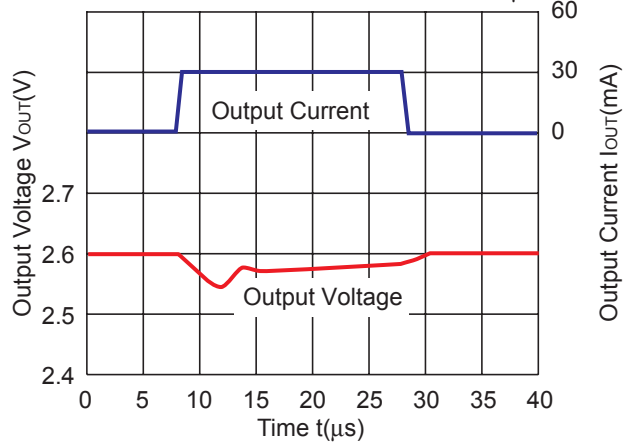

12) Turn on speed with CE pin

R1131x08xx

$V_{IN}=1.8V$ $C_{IN}=\text{Tantalum } 1.0\mu F$,
 $C_{OUT}=\text{Tantalum } 1.0\mu F$

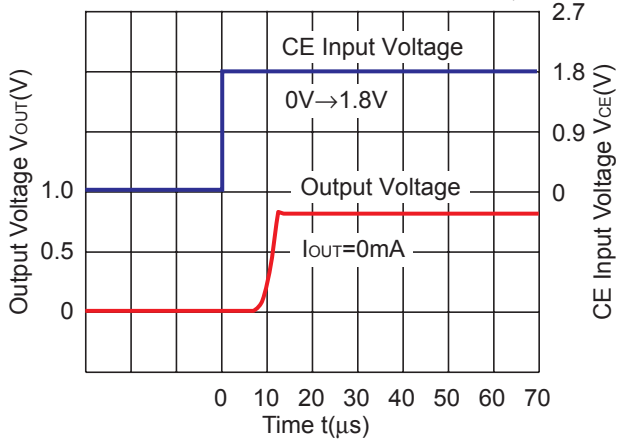

R1131x08xx

$V_{IN}=1.8V$ $C_{IN}=\text{Tantalum } 1.0\mu F$,
 $C_{OUT}=\text{Tantalum } 1.0\mu F$

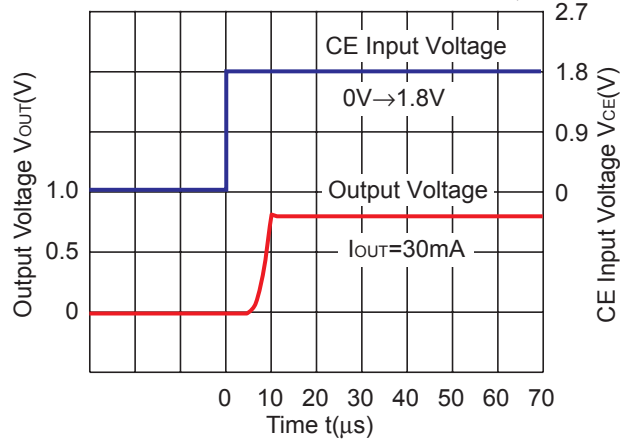

R1131x08xx

$V_{IN}=1.8V$ $C_{IN}=\text{Tantalum } 1.0\mu F$,
 $C_{OUT}=\text{Tantalum } 1.0\mu F$

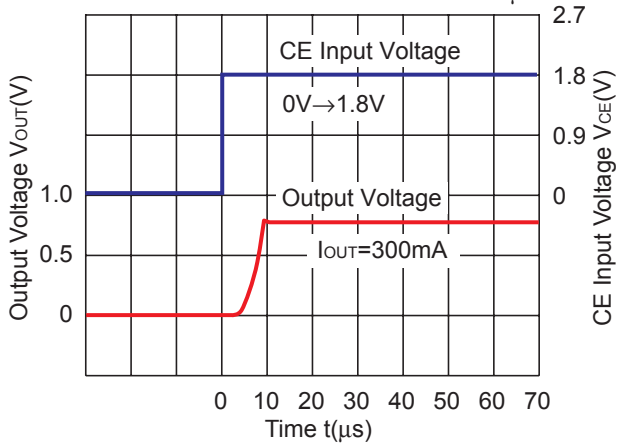

R1131x33xx

$V_{IN}=4.3V$ $C_{IN}=\text{Ceramic } 1.0\mu F$,
 $C_{OUT}=\text{Ceramic } 1.0\mu F$

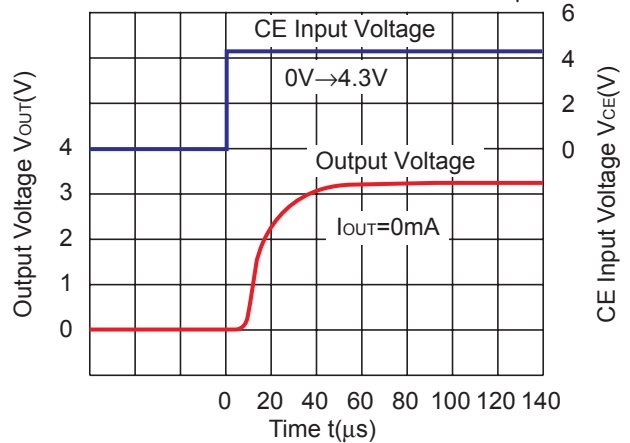

R1131x33xx (ECO=H)

$V_{IN}=4.3V$ C_{IN} =Ceramic $1.0\mu F$,
 C_{OUT} =Ceramic $1.0\mu F$

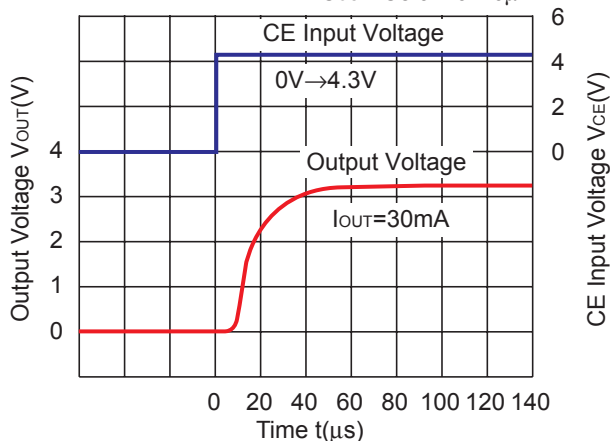

R1131x33xx (ECO=L)

$V_{IN}=4.3V$ C_{IN} =Ceramic $1.0\mu F$,
 C_{OUT} =Ceramic $1.0\mu F$

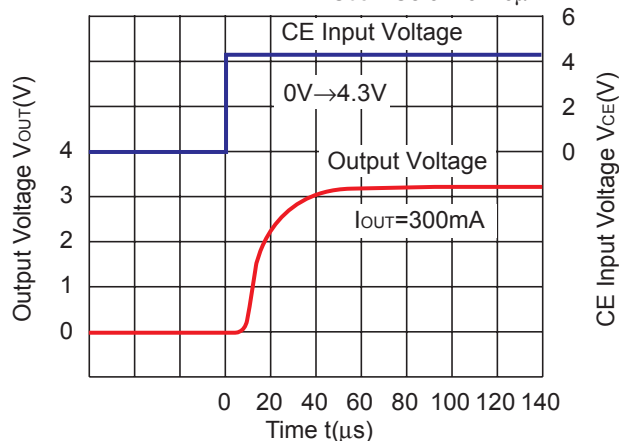

13) Turn-off Speed with CE

R1131x08xD

$V_{IN}=1.8V$ C_{IN} =Tantalum $1.0\mu F$,
 C_{OUT} =Tantalum $1.0\mu F$

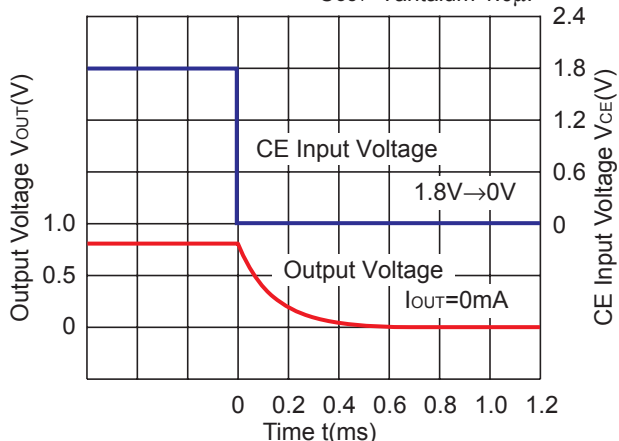

R1131x08xD

$V_{IN}=1.8V$ C_{IN} =Tantalum $1.0\mu F$,
 C_{OUT} =Tantalum $1.0\mu F$

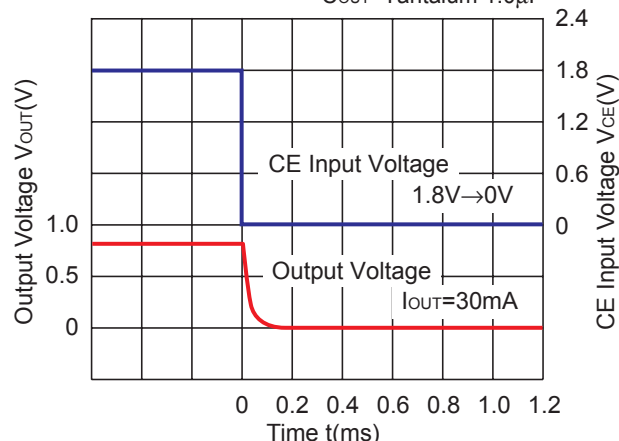

R1131x08xD

$V_{IN}=1.8V$ C_{IN} =Tantalum $1.0\mu F$,
 C_{OUT} =Tantalum $1.0\mu F$

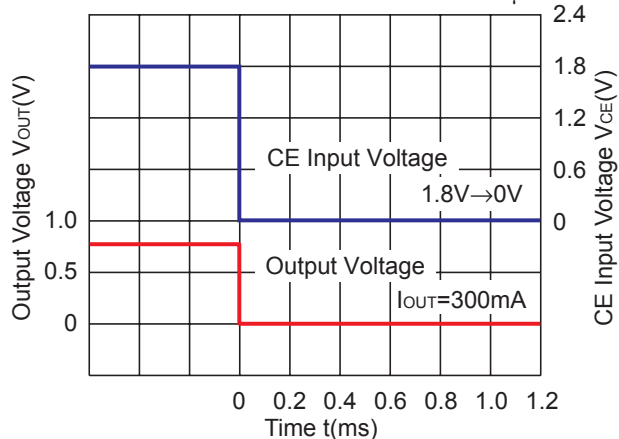

R1131x33xD

$V_{IN}=4.3V$ C_{IN} =Ceramic $1.0\mu F$,
 C_{OUT} =Ceramic $1.0\mu F$

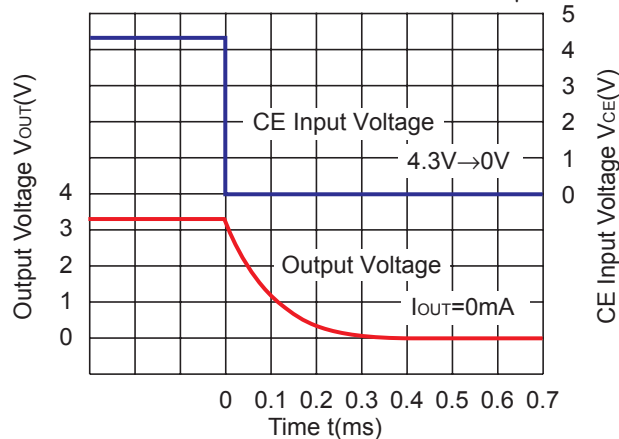

R1131x33xD

$V_{IN}=4.3V$ $C_{IN}=\text{Ceramic } 1.0\mu F,$
 $C_{OUT}=\text{Ceramic } 1.0\mu F$

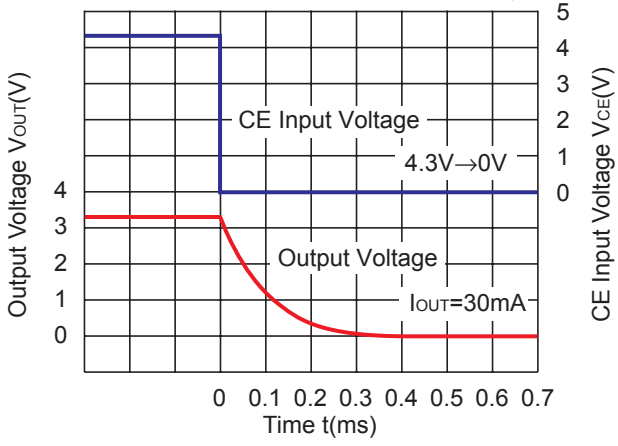

R1131x33xD

$V_{IN}=4.3V$ $C_{IN}=\text{Ceramic } 1.0\mu F,$
 $C_{OUT}=\text{Ceramic } 1.0\mu F$

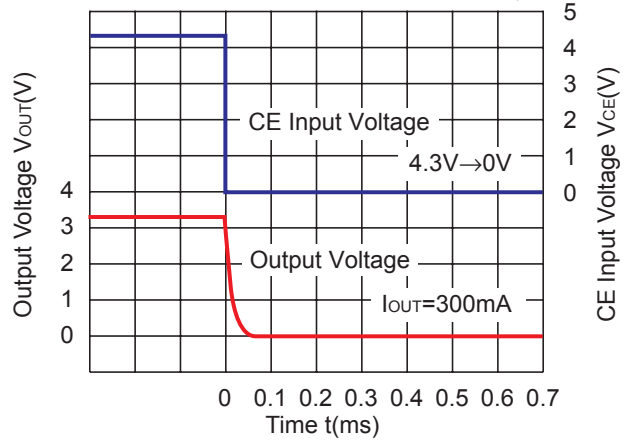

ESR vs. Output Current

When using these ICs, consider the following points:

In these ICs, phase compensation is made for securing stable operation even if the load current is varied. For this purpose, be sure to use a capacitor C_{OUT} with good frequency characteristics and ESR (Equivalent Series Resistance) of which is in the range described as follows:

The relations between I_{OUT} (Output Current) and ESR of Output Capacitor are shown below.

The conditions when the white noise level is under $40\mu\text{V(Avg.)}$ are marked as the hatched area in the graph.

<Test conditions>

- (1) Frequency band: 10Hz to 2MHz
- (2) Temperature: 25°C

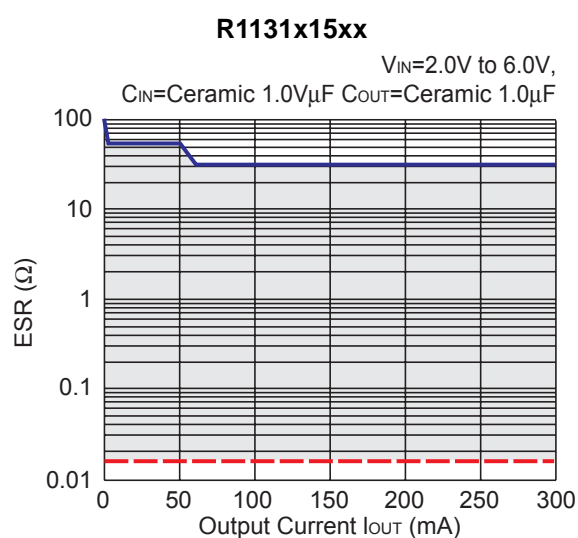
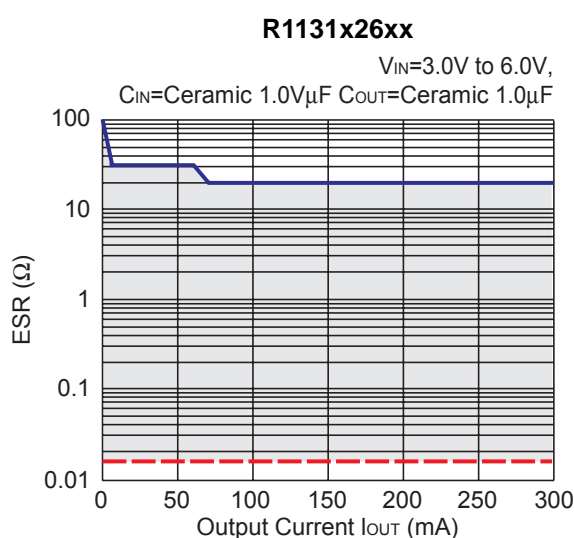
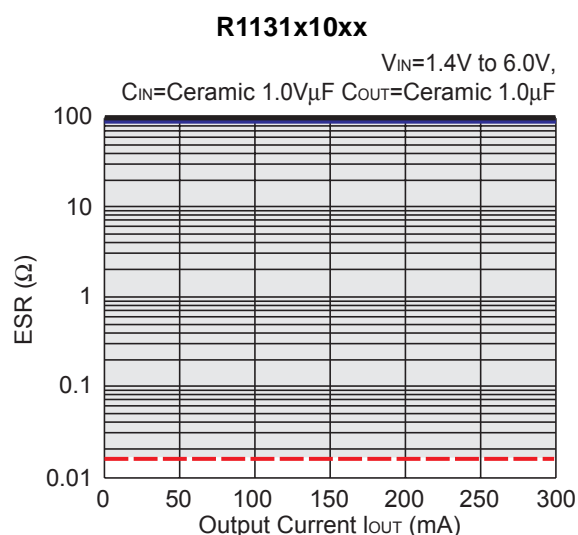
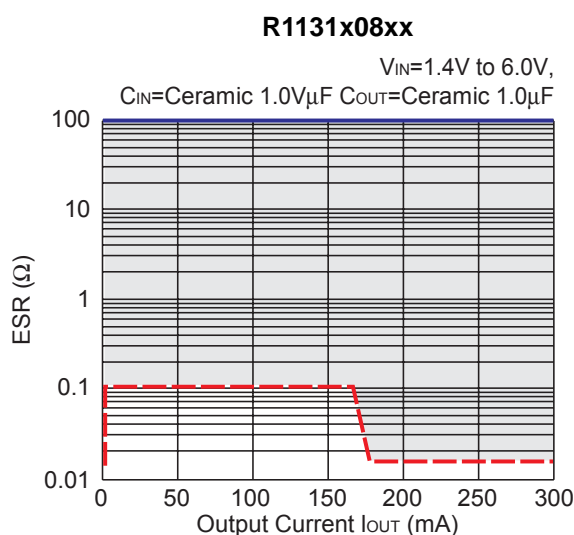

R1131x33xx

$V_{IN}=3.6V$ to $6.0V$,

$C_{IN}=\text{Ceramic } 1.0\mu\text{F}$ $C_{OUT}=\text{Ceramic } 1.0\mu\text{F}$

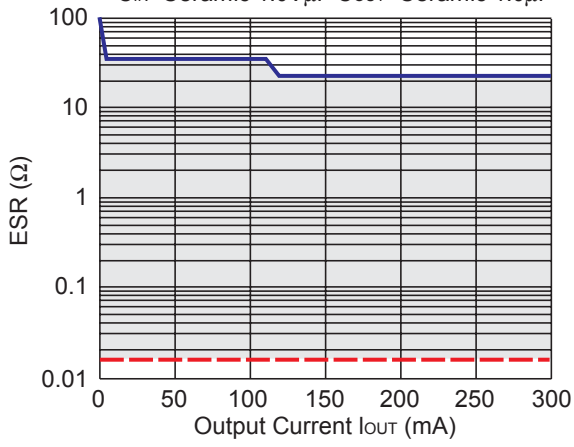



1. The products and the product specifications described in this document are subject to change or discontinuation of production without notice for reasons such as improvement. Therefore, before deciding to use the products, please refer to Ricoh sales representatives for the latest information thereon.
2. The materials in this document may not be copied or otherwise reproduced in whole or in part without prior written consent of Ricoh.
3. Please be sure to take any necessary formalities under relevant laws or regulations before exporting or otherwise taking out of your country the products or the technical information described herein.
4. The technical information described in this document shows typical characteristics of and example application circuits for the products. The release of such information is not to be construed as a warranty of or a grant of license under Ricoh's or any third party's intellectual property rights or any other rights.
5. The products listed in this document are intended and designed for use as general electronic components in standard applications (office equipment, telecommunication equipment, measuring instruments, consumer electronic products, amusement equipment etc.). Those customers intending to use a product in an application requiring extreme quality and reliability, for example, in a highly specific application where the failure or misoperation of the product could result in human injury or death (aircraft, spacevehicle, nuclear reactor control system, traffic control system, automotive and transportation equipment, combustion equipment, safety devices, life support system etc.) should first contact us.
6. We are making our continuous effort to improve the quality and reliability of our products, but semiconductor products are likely to fail with certain probability. In order to prevent any injury to persons or damages to property resulting from such failure, customers should be careful enough to incorporate safety measures in their design, such as redundancy feature, firecontainment feature and fail-safe feature. We do not assume any liability or responsibility for any loss or damage arising from misuse or inappropriate use of the products.
7. Anti-radiation design is not implemented in the products described in this document.
8. Please contact Ricoh sales representatives should you have any questions or comments concerning the products or the technical information.

RICOH COMPANY., LTD. Electronic Devices Company



■ Ricoh presented with the Japan Management Quality Award for 1999.
Ricoh continually strives to promote customer satisfaction, and shares the achievements of its management quality improvement program with people and society.



■ Ricoh awarded ISO 14001 certification.
The Ricoh Group was awarded ISO 14001 certification, which is an international standard for environmental management systems, at both its domestic and overseas production facilities. Our current aim is to obtain ISO 14001 certification for all of our business offices.

<http://www.ricoh.com/LSI/>

RICOH COMPANY, LTD. Electronic Devices Company

● Higashi-Shinagawa Office (International Sales)
3-32-3, Higashi-Shinagawa, Shinagawa-ku, Tokyo 140-8655, Japan
Phone: +81-3-5479-2857 Fax: +81-3-5479-0502

RICOH EUROPE (NETHERLANDS) B.V.

● Semiconductor Support Centre
Prof. W.H.Keesomlaan 1, 1183 DL Amstelveen, The Netherlands
P.O.Box 114, 1180 AC Amstelveen
Phone: +31-20-5474-309 Fax: +31-20-5474-791

RICOH ELECTRONIC DEVICES KOREA Co., Ltd.

11 floor, Haesung 1 building, 942, Daechidong, Gangnamgu, Seoul, Korea
Phone: +82-2-2135-5700 Fax: +82-2-2135-5705

RICOH ELECTRONIC DEVICES SHANGHAI Co., Ltd.

Room403, No.2 Building, 690#Bi Bo Road, Pu Dong New district, Shanghai 201203,
People's Republic of China
Phone: +86-21-5027-3200 Fax: +86-21-5027-3299

RICOH COMPANY, LTD. Electronic Devices Company

● Taipei office
Room109, 10F-1, No.51, Hengyang Rd., Taipei City, Taiwan (R.O.C.)
Phone: +886-2-2313-1621/1622 Fax: +886-2-2313-1623



Ricoh completed the organization of the Lead-free production for all of our products. After Apr. 1, 2006, we will ship out the lead free products only. Thus, all products that will be shipped from now on comply with RoHS Directive.