

• WLCSP-4-P5

Unit: mm

PACKAGE DIMENSIONS

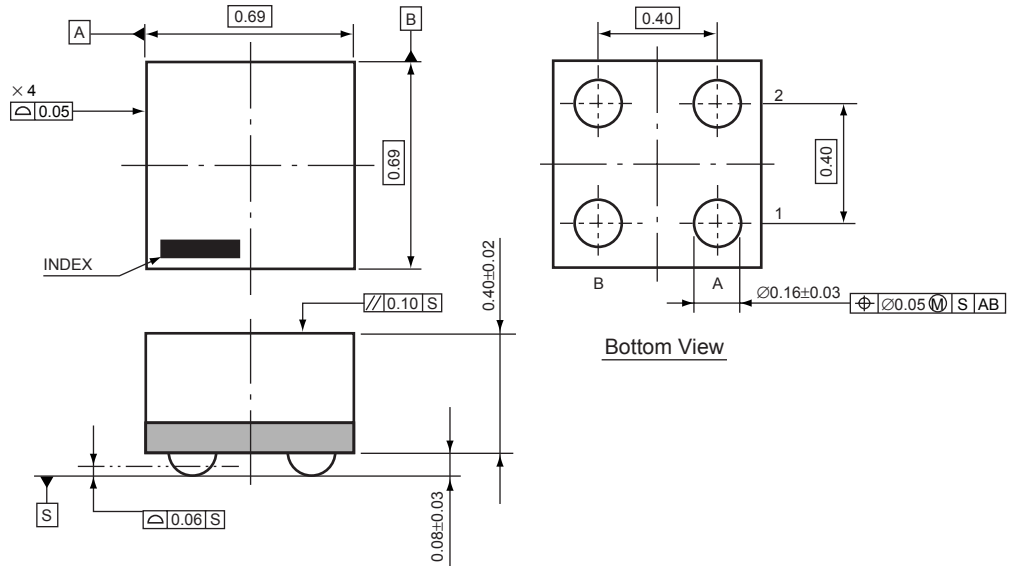

TAPING REEL DIMENSIONS REUSE REEL (EIAJ-RRM-08Bc)

(1reel=5,000pcs)

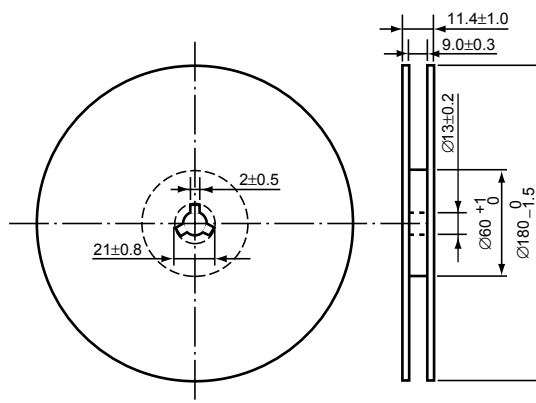

POWER DISSIPATION (WLCSP-4-P5)

This specification is at mounted on board. Power Dissipation (P_D) depends on conditions of mounting on board. This specification is based on the measurement at the condition below:

Measurement Conditions

	Standard Land Pattern
Environment	Mounting on Board (Wind velocity=0m/s)
Board Material	Glass cloth epoxy plastic (Double sided)
Board Dimensions	40mm × 40mm × 1.6mm
Copper Ratio	Top side : Approx. 50%, Back side : Approx. 50%
Through-holes	φ0.5mm × 28pcs

Measurement Results

($T_{opt}=25^{\circ}C$, $T_{jmax}=125^{\circ}C$)

	Standard Land Pattern
Power Dissipation	278mW
Thermal Resistance	$\theta_{ja}=(125-25^{\circ}C)/0.278W=360^{\circ}C/W$
Thermal Resistance	$\theta_{jc}=46^{\circ}C/W$

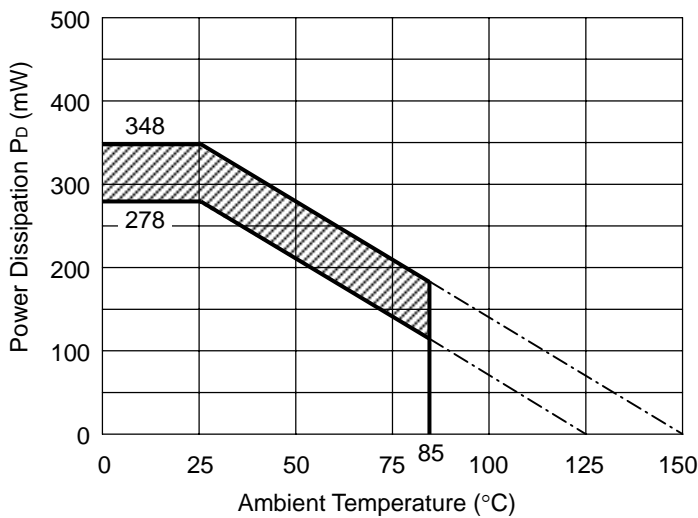

Power Dissipation

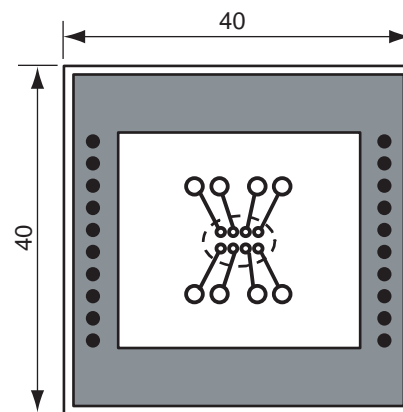

Measurement Board Pattern

○ IC Mount Area (Unit:mm)

The above graph shows the Power Dissipation of the package based on $T_{jmax}=125^{\circ}C$ and $T_{jmax}=150^{\circ}C$. Operating the IC in the shaded area in the graph might have an influence it's lifetime.

Operating time must be within the time limit described in the table below, in case of operating in the shaded area.

Product Name	Operating time	Estimated years (Operating four hours/day)
RP200Z	13,000 hrs	9 years

RECOMMENDED LAND PATTERN

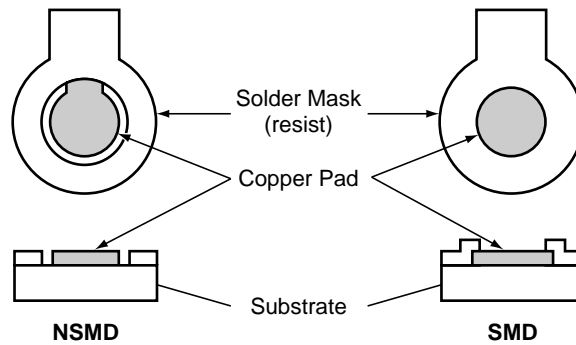

NSMD and SMD Pad Definition

Pad definition	Copper Pad	Solder Mask Opening
NSMD (Non-Solder Mask defined)	0.20mm	Min. 0.30mm
SMD (Solder Mask defined)	Min. 0.30mm	0.20mm

- * Pad layout and size can be modified by customers material, equipment, method.
- * Please adjust pad layout according to your conditions.
- * Recommended Stencil Aperture Size....ø0.3mm
- * Since lead free WLCSP components are not compatible with the tin/lead solder process, you shall not mount lead free WLCSP components using the tin/lead solder paste.