

• DFN1212-6

Unit: mm

PACKAGE DIMENSIONS

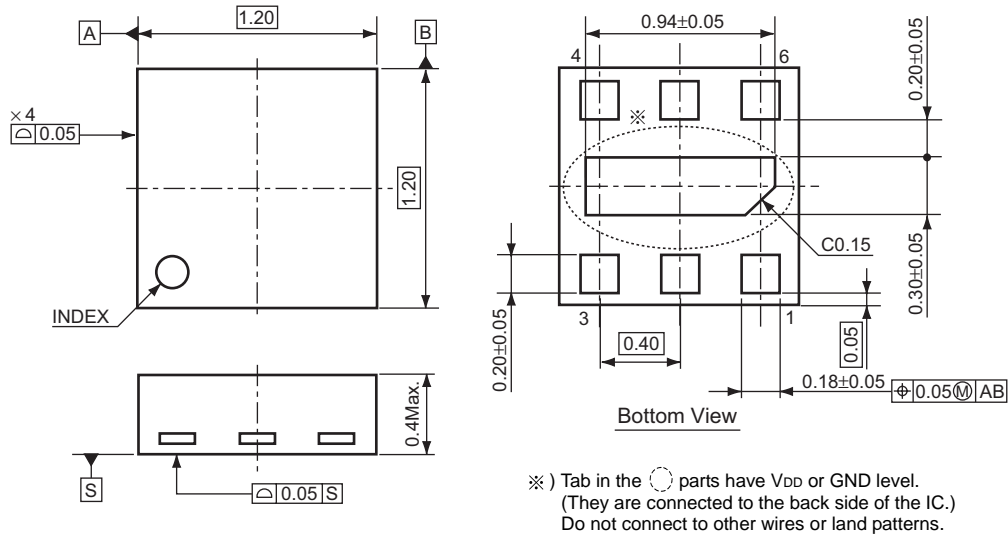

TAPING SPECIFICATION

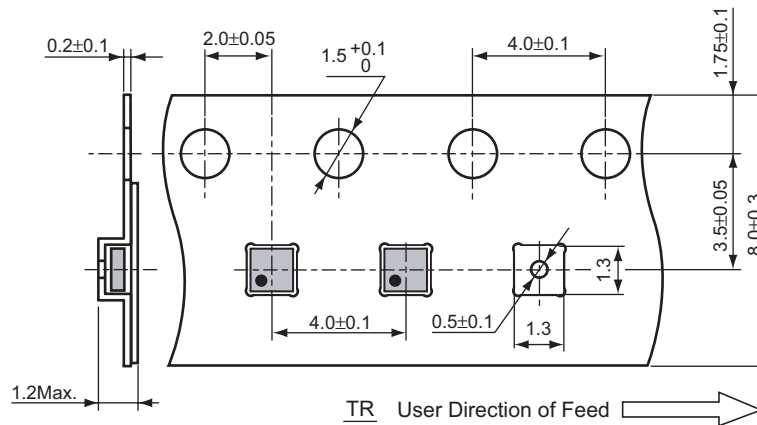

TAPING REEL DIMENSIONS REUSE REEL (EIAJ-RRM-08Bc)

(1reel=5,000pcs)

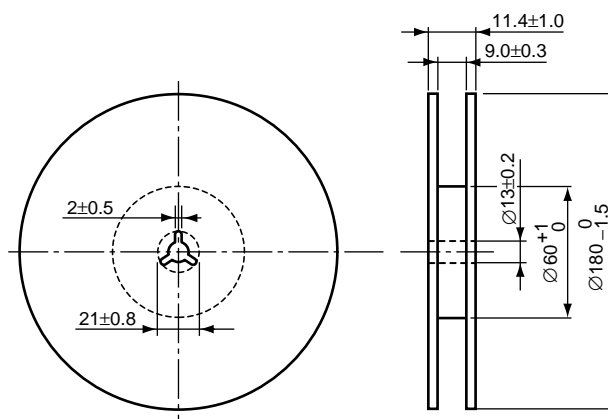

POWER DISSIPATION (DFN1212-6)

This specification is at mounted on board. Power Dissipation (P_D) depends on conditions of mounting on board. This specification is based on the measurement at the condition below:

Measurement Conditions

	Standard Land Pattern
Environment	Mounting on Board (Wind velocity=0m/s)
Board Material	Glass cloth epoxy plastic (Double sided)
Board Dimensions	40mm × 40mm × 1.6mm
Copper Ratio	Top side : Approx. 50% , Back side : Approx. 50%
Through-holes	φ0.5mm × 28pcs

Measurement Results ($T_{opt}=25^{\circ}C$, $T_{jmax}=125^{\circ}C$)

	Standard Land Pattern
Power Dissipation	600mW
Thermal Resistance	$\theta_{ja}=(125-25^{\circ}C)/0.6W=167^{\circ}C/W$
Thermal Resistance	$\theta_{jc}=30^{\circ}C/W$

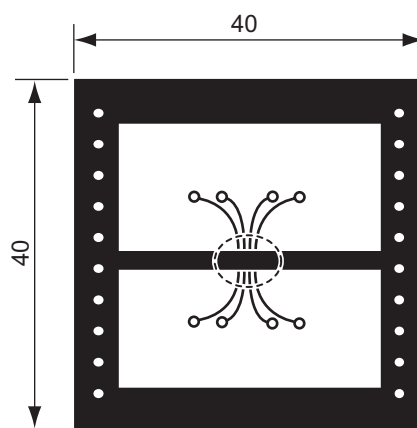
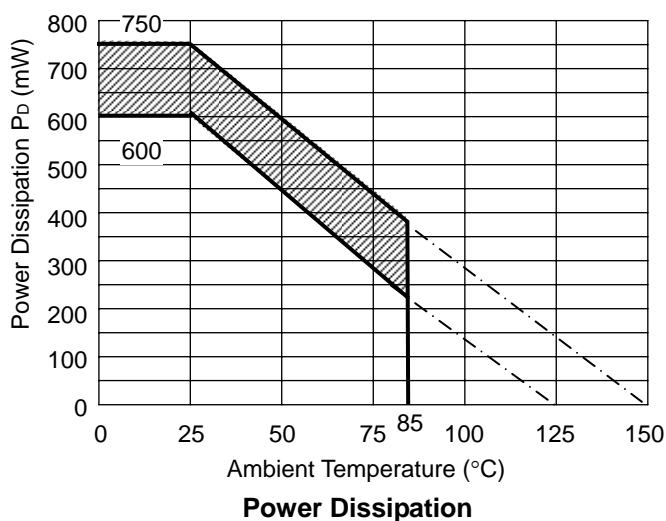

Measurement Board Pattern
 ○ IC Mount Area (Unit: mm)

The above graph shows the Power Dissipation of the package based on $T_{jmax}=125^{\circ}C$ and $T_{jmax}=150^{\circ}C$.

Operating the IC in the shaded area in the graph might have an influence it's lifetime.

Operating time must be within the time limit described in the table below, in case of operating in the shaded area.

Product Name	Operating time	Estimated years*
RP152L	13,000hrs	9 years

*The volume is calculated on the supposition that operating four hours/day.

RECOMMENDED LAND PATTERN

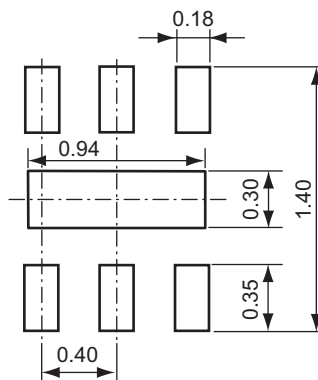

(Unit: mm)