

---

## PCMCIA Power Controller

---

NO.EA-176-090709

### OUTLINE

The R5533V Series switch the  $V_{CC}$  voltage among 0V, 3.3V or 5.0V. And the  $V_{PP}$  voltage is outputted in between either OFF, 0V, 3.3V or 5.0V conditions.

When the  $V_{CC}$  or  $V_{PP}$  pin are short-circuited to the GND, the minimum current limit protection values are  $V_{CC}$  pin=1A and  $V_{PP}$  pin=0.2A. R5533V is suitable for standard type of PCMCIA power controllers.

### FEATURES

- Low ON resistance Nch MOSFET switch
- Built-in Over Current Limit Protection Function
- Built-in Thermal Shutdown Protection
- Open Drain Flag Pin
- Break-Before-Make Switching
- Package: SSOP-16 pin

### APPLICATIONS

- Power Supply Switch for PC Card
- Power Supply Control for a card-bus slot
- PC Card Reader / Writer

## BLOCK DIAGRAMS

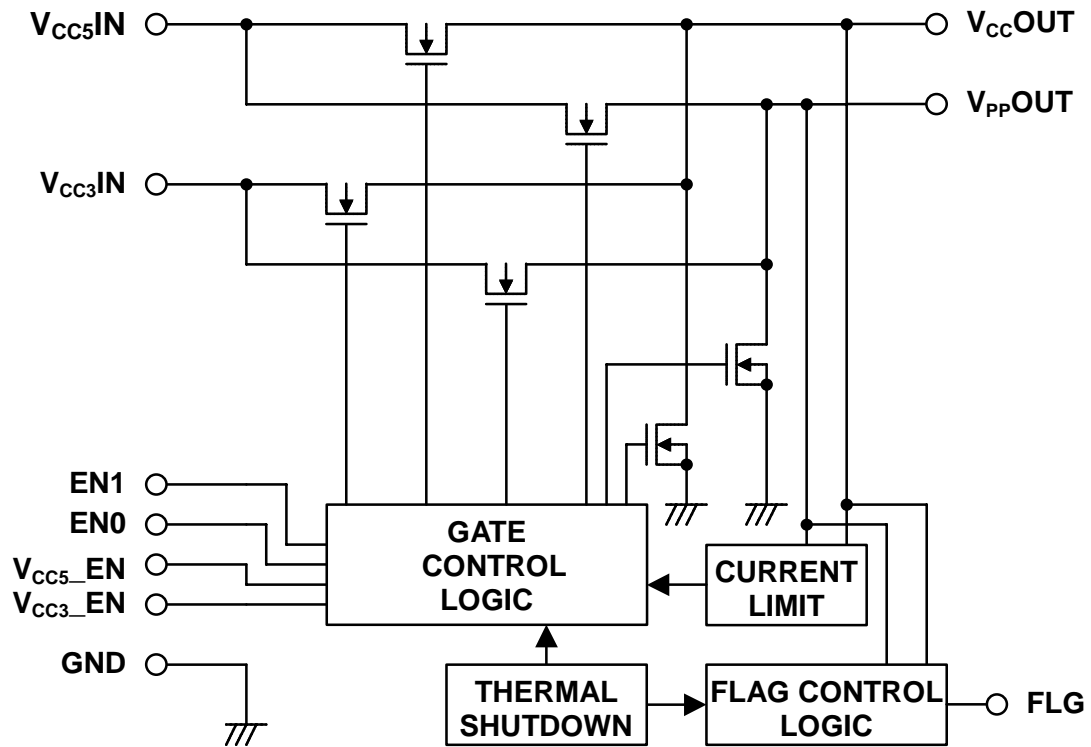

## PIN CONFIGURATIONS

### • SSOP-16

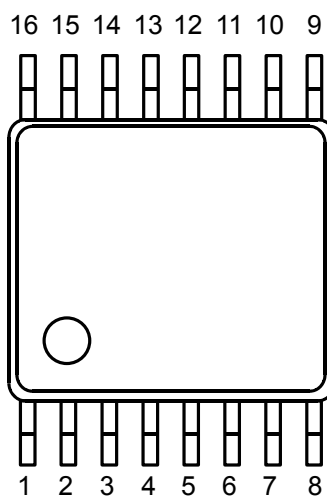

## PIN DESCRIPTIONS

Pin No.	Symbol	Description
1	V <sub>CC5</sub> _EN	Logic Input Pin
2	V <sub>CC3</sub> _EN	Logic Input Pin
3	EN0	Logic Input Pin
4	EN1	Logic Input Pin
5	FLG	Flag Output Pin
6	TST	Test Pin
7	NC	No Connection
8	V <sub>PP</sub> OUT	V <sub>PP</sub> Output Pin
9	V <sub>CC</sub> OUT	V <sub>CC</sub> Output Pin
10	NC	No Connection
11	V <sub>CC3</sub> IN	3V Input Pin
12	V <sub>CC</sub> OUT	V <sub>CC</sub> Output Pin
13	V <sub>CC5</sub> IN	5V Input Pin
14	V <sub>CC</sub> OUT	V <sub>CC</sub> Output Pin
15	V <sub>CC5</sub> IN	5V Input Pin
16	GND	Ground Pin

## ABSOLUTE MAXIMUM RATINGS

(GND=0V)

Symbol	Item	Rating	Unit
$V_{CC5IN}$	Input Voltage (5V)	- 0.3 to 6.0	V
$V_{CC3IN}$	Input Voltage (3V)	- 0.3 to 6.0	V
$V_{FLG}$	Flag Voltage	- 0.3 to 6.0	V
$V_{IN}$	Logic Input Voltage	- 0.3 to 6.0	V
$V_{TST}$	Test Pin Voltage	- 0.3 to 6.0	V
$P_D$	Power Dissipation *	TBD	mW
$T_a$	Ambient Temperature Range	- 40 to 85	°C
$T_{stg}$	Storage Temperature Range	- 55 to 125	°C

### ABSOLUTE MAXIMUM RATINGS

Electronic and mechanical stress momentarily exceeded absolute maximum ratings may cause the permanent damages and may degrade the life time and safety for both device and system using the device in the field. The functional operation at or over these absolute maximum ratings is not assured.

### RECOMMENDED OPERATING CONDITIONS (ELECTRICAL CHARACTERISTICS)

All of electronic equipment should be designed that the mounted semiconductor devices operate within the recommended operating conditions. The semiconductor devices cannot operate normally over the recommended operating conditions, even if when they are used over such conditions by momentary electronic noise or surge. And the semiconductor devices may receive serious damage when they continue to operate over the recommended operating conditions.

## RECOMMENDATION OF OPERATING CONDITION

(Ta=25°C)

Item	Symbol	Rating
Input Voltage (5V)	$V_{CC5IN}$	4.5V to 5.5V
Input Voltage (3V)	$V_{CC3IN}$	3.0V to 3.6V
Output Current	$I_O(V_{CC})$	$I_O(V_{CC}) < 1A$
	$I_O(V_{PP})$	$I_O(V_{PP}) < 100mA$

## ELECTRICAL CHARACTERISTICS

$V_{CC5IN} = 5V$ ,  $V_{CC3IN} = 3.3V$ , unless otherwise noted.

The specification is guaranteed by design engineering at  $-40^{\circ}C \leq Ta \leq 85^{\circ}C$ . The typical value is at  $Ta = 25^{\circ}C$ .

Ta=25°C

Item	Symbol	Conditions	Min.	Typ.	Max.	Unit
Supply Current	$I_{CC5}$	$V_{CCOUT} = 5V$ or $3.3V$		180	340	$\mu A$
Supply Current	$I_{SLP5}$	$V_{CCOUT} = 0V$ (Sleep Mode)		0.2	10	$\mu A$
Supply Current	$I_{CC3}$	$V_{CCOUT} = 5V$ or $3.3V$		7	20	$\mu A$
Supply Current	$I_{SLP3}$	$V_{CCOUT} = 0V$ (Sleep Mode)		0.2	10	$\mu A$
$V_{CCOUT}$ Switch Resistance	$R_{OVCC}$	Select $V_{CCOUT} = 5V$		90	140	m $\Omega$
		Select $V_{CCOUT} = 3.3V$		85	140	m $\Omega$
		Select $V_{CCOUT} = 0V$	300	500	1100	$\Omega$
$V_{PPOUT}$ Switch Resistance	$R_{OVPP}$	Select $V_{PPOUT} = 5V$		1	1.5	$\Omega$
		Select $V_{PPOUT} = 3.3V$		1	1.5	$\Omega$
		Select $V_{PPOUT} = 0V$	1500	2500	3900	$\Omega$
$V_{PPOUT}$ Leakage Current	$I_{PPL}$	Select $V_{PPOUT} = Hi-Z$		1	10	$\mu A$
Reverse Leakage Current	$I_{CC}$	$V_{CC5IN} = V_{CC3IN} = 0V$		3	50	$\mu A$
	$I_{PP}$	$V_{CC5IN} = V_{CC3IN} = 0V$		3	50	$\mu A$
Short Current Limit	$I_{CCSC}$	$V_{CCOUT} = 0V$	1	1.7	2.5	A
	$I_{PPSC}$	$V_{PPOUT} = 0V$	0.2	0.4	0.7	A
Short Current Limit Response Time *1	$t_{RES}(I_{CCSC})$	$V_{CCOUT} = 0V$		50		$\mu s$
	$t_{RES}(I_{PPSC})$	$V_{PPOUT} = 0V$		20		$\mu s$
Logic Input "H" Voltage	$V_{IH}$		2.0		6.0	V
Logic Input "L" Voltage	$V_{IL}$		-0.3		0.8	V
Logic Input Current	$I_{IN}$				$\pm 1$	$\mu A$
Thermal Shutdown Temperature	$T_{SD}$			140		$^{\circ}C$
Hysteresis *2				10		$^{\circ}C$
Flag Threshold Voltage	$V_{OK}$	FLG is pulled up to $V_{CC3IN}$ with $10k\Omega$		$V_{CC}-1$ $V_{PP}-1$		V
Flag Voltage "L"	$V_{FLG}$	$I_{OL} = 2mA$		0.3		V
Flag OFF Leakage Current	$I_{FLGOFF}$	$V_{IN} = V_{FLG} = 5.5V$			1	$\mu A$

\*1 The specification is checked and guaranteed by design engineering

\*2 The value of Hysteresis is calculated by the thermal Shutdown Temperature. It does not test.

## ELECTRICAL CHARACTERISTICS (cont.)

$V_{CC5IN} = 5V$ ,  $V_{CC3IN} = 3.3V$ , unless otherwise noted.

The specification is guaranteed by design engineering at  $-40^{\circ}C \leq Ta \leq 85^{\circ}C$ . The typical value is in  $Ta = 25^{\circ}C$ .

Ta=25°C

Item	Symbol	Conditions	Min.	Typ.	Max.	Unit
V <sub>CC</sub> Turn-ON Delay Time *2	t1	V <sub>CC</sub> =3.3V Time until 10% in 3.3V from EN.	0.1	0.4	0.8	ms
	t2	V <sub>CC</sub> =5.0V Time until 10% in 5.0V from EN.	0.15	0.45	1.0	ms
V <sub>CC</sub> Rising Time *2	t3	V <sub>CC</sub> =3.3V Time until 90% from 10% in 3.3V.	0.3	0.6	1.2	ms
	t4	V <sub>CC</sub> =5.0V Time until 90% from 10% in 5.0V.	0.5	1.1	1.7	ms
V <sub>CC</sub> Turn-OFF Delay Time *1,*2,*4	t7	V <sub>CC</sub> =3.3V Time until Hi-Z from EN.	0.7	2	8.0	ms
	t8	V <sub>CC</sub> =5.0V Time until Hi-Z from EN	0.9	2.1	6.0	ms
V <sub>CC</sub> Falling Time *2	t5	V <sub>CC</sub> =3.3V Time until 10% from 90% in 3.3V.	0.2	0.7	1.8	ms
	t6	V <sub>CC</sub> =5.0V Time until 10% from 90% in 5.0V.	0.2	0.7	2.0	ms
V <sub>PP</sub> Turn-ON Deay Time *3	t9	V <sub>PP</sub> =3.3V Time until 10% in 3.3V from EN.	30	100	210	μs
	t10	V <sub>PP</sub> =5.0V Time until 10% in 5.0V from EN.	40	120	230	μs
V <sub>PP</sub> Rising Time *3	t11	V <sub>PP</sub> =3.3V Time until 90% from 10% in 3.3V.	80	180	350	μs
	t12	V <sub>PP</sub> =5.0V Time until 90% from 10% in 5.0V.	120	280	650	μs
V <sub>PP</sub> Turn-OFF Delay Time *1,*3	t15	V <sub>PP</sub> =3.3V Time until Hi-Z from EN.	20	50	160	ns
	t16	V <sub>PP</sub> =5.0V Time until Hi-Z from EN	30	50	150	ns
V <sub>PP</sub> Falling Time *3	t13	V <sub>PP</sub> =3.3V Time until 10% from 90% in 3.3V.	10	30	80	ns
	t14	V <sub>PP</sub> =5.0V Time until 10% from 90% in 5.0V.	10	30	80	ns

\*1 The time between the beginning of falling time of the output from the change of EN.

\*2 The measurement condition of t1 ~ t8: RL = 10Ω

\*3 The measurement condition of t9 ~ t16: RL = 100Ω

\*4 Please avoid the status on current limit or thermal shutdown during t7 and t8.

**TIMING CHART**

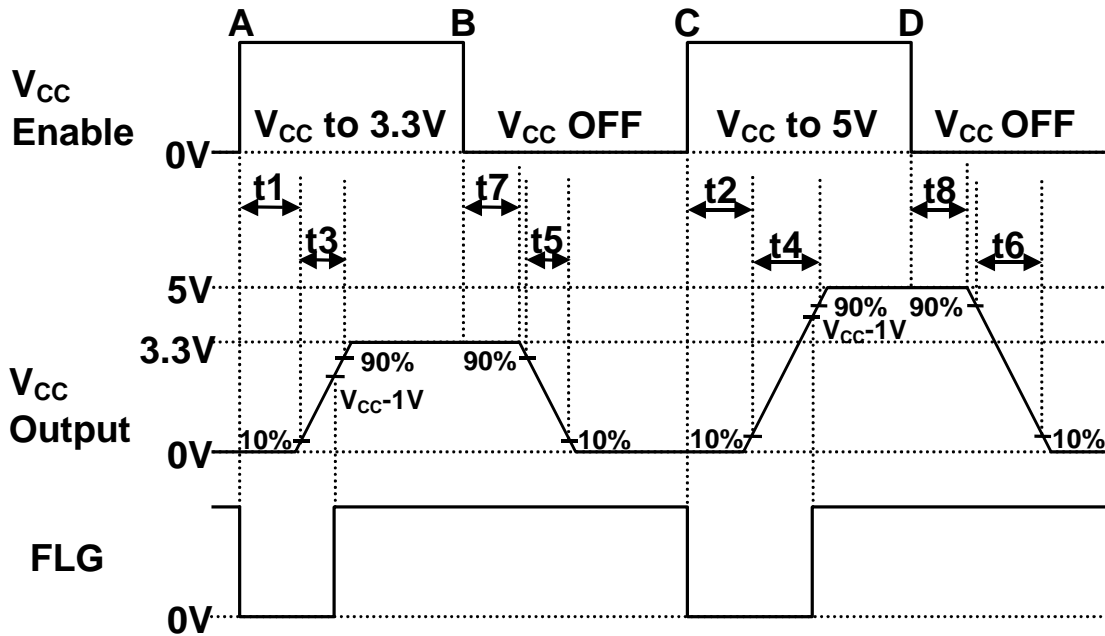

Fig1 Timing Diagram of V<sub>CC</sub>

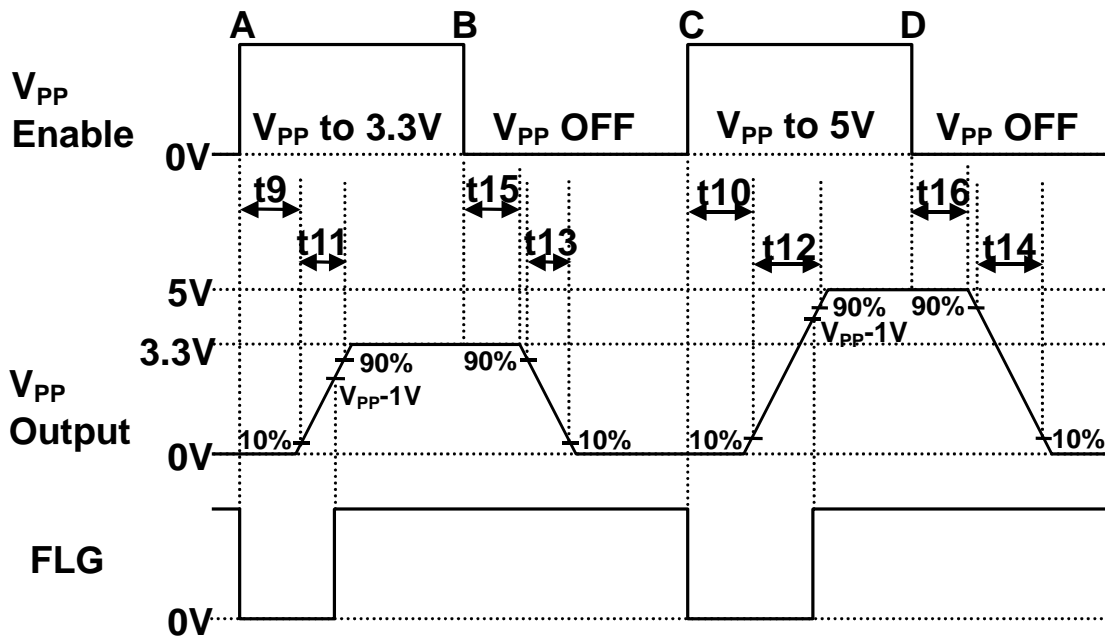

Fig 2 Timing Diagram of V<sub>PP</sub>

## OPERATION

### OPERATING EXPLANATION

When the  $V_{CCOUT}=0V$  is selected, the IC switches into the sleep mode, the supply current decreases to nano-amperes.

If commanded to switch from 5.0V to 3.3V, or vice versa from 3.3V to 5.0V, without selecting  $V_{CCOUT}=0V$  between switching. In this case, enhancement of the second switch begins after the first is OFF, that is called as “the break-before-make switching”.

If the condition of the over-current limit caused by the OUT pin clamped to the GND were continue the temperature of the ICs would increase drastically. The switch-transistor is turned OFF if the temperature of the ICs becomes over 140°C (Typ.). And after this, the switch-transistor is turned ON again when the temperature of ICs decreased approximately 10°C. The switch-transistor keeps continual ON and OFF until either the switch is turned OFF or the OUT pin is removed from GND.

The Short Current Limit is fixed internal ICs. The response at the over-current is the following two types. (1) The ICs become constant current state immediately if the ICs are turned ON under the condition that the OUT pin is shorted or the large capacity is loaded. The current value in the state of constant current is the short current limit. (2) The large transient current flows until the current limit circuit responds, if the OUT pin is shorted or the large capacity is loaded under the condition that the switch-transistor is turned ON. The transient current is depending on the impedance from the power supply circuit of  $V_{CC5IN} / V_{CC3IN}$  to the output load. It means that the transient current depends upon the transient response characteristics of the power supply circuits of  $V_{CC5IN} / V_{CC3IN}$ , PCB layout or the card connector. After the current limit circuit is responded, the short current limit flows as the condition of constant current.

### TYPICAL APPLICATION

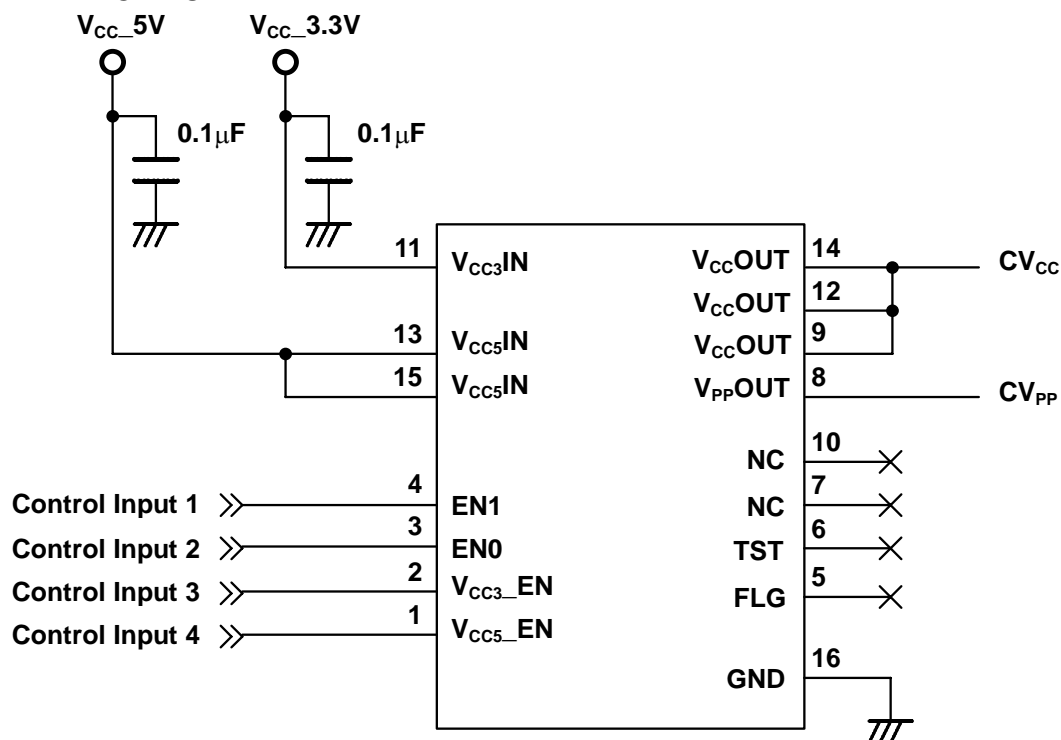

Note: The signal from Control Input1~4 provided by PCMCIA control.

**CONTROL LOGIC TABLE**

$V_{CC5\_EN}$	$V_{CC3\_EN}$	EN1	EN0	$V_{CCOUT}$	$V_{PPOUT}$
0	0	0	0	0 V	0 V
0	0	0	1	0 V	Hi-Z
0	0	1	0	0 V	Hi-Z
0	0	1	1	0 V	Hi-Z
0	1	0	0	5 V	0 V
0	1	0	1	5 V	5 V
0	1	1	0	5 V	Hi-Z
0	1	1	1	5 V	Hi-Z
1	0	0	0	3.3 V	0 V
1	0	0	1	3.3 V	3.3 V
1	0	1	0	3.3 V	Hi-Z
1	0	1	1	3.3 V	Hi-Z
1	1	0	0	0 V	0 V
1	1	0	1	0 V	Hi-Z
1	1	1	0	0 V	Hi-Z
1	1	1	1	0 V	Hi-Z

**APPLICATION NOTES**

Connect a by-pass capacitor value from 0.1 $\mu$ F to 1.0 $\mu$ F between  $V_{CC5IN}$  and GND pin,  $V_{CC3IN}$  and GND pin.  
Please connect the same function pins to one another.  
TST pin (Pin 6) should be OPEN.

## TEST CIRCUITS

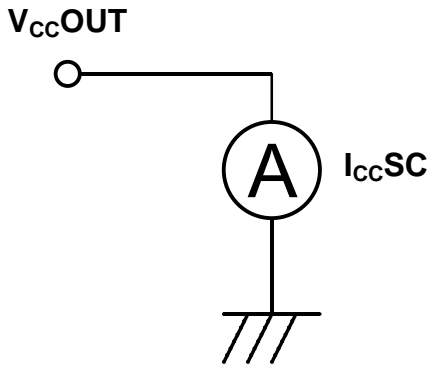

Fig.1  $I_{CC}SC$

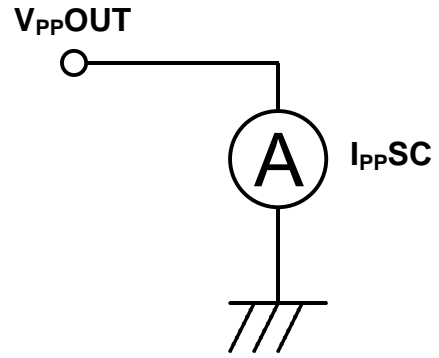

Fig.2  $I_{PP}SC$

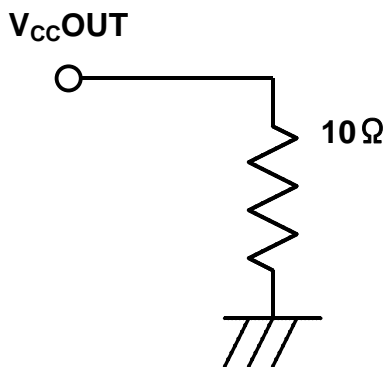

Fig.3 t1~t8

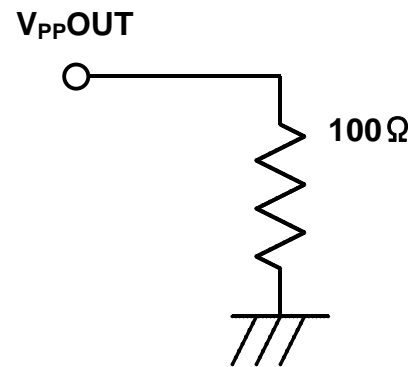

Fig.3 t9~t16

Note 1: The test circuits of all other pins, except  $V_{CC}OUT$  pin and  $V_{PP}OUT$  pins refer to the TYPICAL APPLIICATIONS (p.8).

Note 2: Please connect a  $10k\ \Omega$  resistance with between FLG pin and  $V_{CC3}IN$  pin when the threshold of FLG pin voltage is testing.

## TYPICAL CHARACTERISTICS

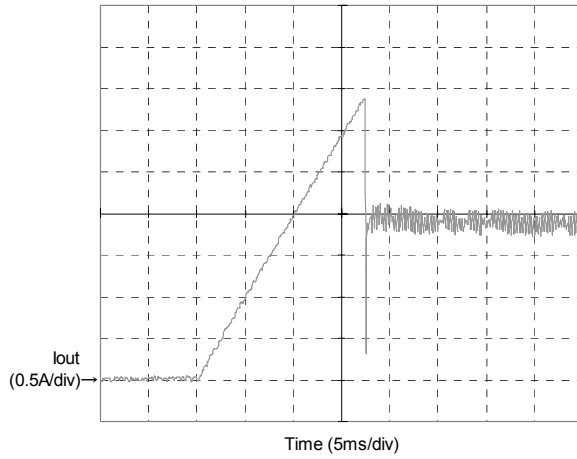

Fig.1 Ramped Load Connected to an Enabled Device

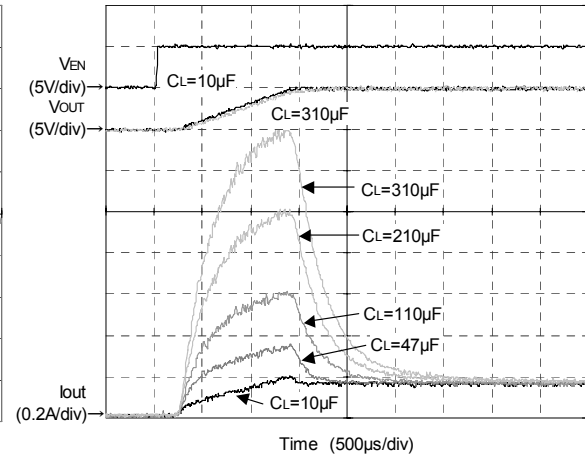

Fig.2 Rush Current



1. The products and the product specifications described in this document are subject to change or discontinuation of production without notice for reasons such as improvement. Therefore, before deciding to use the products, please refer to Ricoh sales representatives for the latest information thereon.
2. The materials in this document may not be copied or otherwise reproduced in whole or in part without prior written consent of Ricoh.
3. Please be sure to take any necessary formalities under relevant laws or regulations before exporting or otherwise taking out of your country the products or the technical information described herein.
4. The technical information described in this document shows typical characteristics of and example application circuits for the products. The release of such information is not to be construed as a warranty of or a grant of license under Ricoh's or any third party's intellectual property rights or any other rights.
5. The products listed in this document are intended and designed for use as general electronic components in standard applications (office equipment, telecommunication equipment, measuring instruments, consumer electronic products, amusement equipment etc.). Those customers intending to use a product in an application requiring extreme quality and reliability, for example, in a highly specific application where the failure or misoperation of the product could result in human injury or death (aircraft, spacevehicle, nuclear reactor control system, traffic control system, automotive and transportation equipment, combustion equipment, safety devices, life support system etc.) should first contact us.
6. We are making our continuous effort to improve the quality and reliability of our products, but semiconductor products are likely to fail with certain probability. In order to prevent any injury to persons or damages to property resulting from such failure, customers should be careful enough to incorporate safety measures in their design, such as redundancy feature, firecontainment feature and fail-safe feature. We do not assume any liability or responsibility for any loss or damage arising from misuse or inappropriate use of the products.
7. Anti-radiation design is not implemented in the products described in this document.
8. Please contact Ricoh sales representatives should you have any questions or comments concerning the products or the technical information.

## RICOH COMPANY., LTD. Electronic Devices Company



■ Ricoh presented with the Japan Management Quality Award for 1999.  
Ricoch continually strives to promote customer satisfaction, and shares the achievements of its management quality improvement program with people and society.



■ Ricoh awarded ISO 14001 certification.  
The Ricoh Group was awarded ISO 14001 certification, which is an international standard for environmental management systems, at both its domestic and overseas production facilities. Our current aim is to obtain ISO 14001 certification for all of our business offices.

<http://www.ricoh.com/LSI/>

### RICOH COMPANY, LTD. Electronic Devices Company

● **Shin-Yokohama office (International Sales)**  
3-2-3, Shin-Yokohama, Kohoku-ku, Yokohama City, Kanagawa 222-8530, Japan  
Phone: +81-45-477-1697 Fax: +81-45-477-1698

### RICOH EUROPE (NETHERLANDS) B.V.

● **Semiconductor Support Centre**  
Prof. W.H.Keesomlaan 1, 1183 DL Amstelveen, The Netherlands  
P.O.Box 114, 1180 AC Amstelveen  
Phone: +31-20-5474-309 Fax: +31-20-5474-791

### RICOH ELECTRONIC DEVICES KOREA Co., Ltd.

11 floor, Haesung 1 building, 942, Daechidong, Gangnamgu, Seoul, Korea  
Phone: +82-2-2135-5700 Fax: +82-2-2135-5705

### RICOH ELECTRONIC DEVICES SHANGHAI Co., Ltd.

Room403, No.2 Building, 690#Bi Bo Road, Pu Dong New district, Shanghai 201203,  
People's Republic of China  
Phone: +86-21-5027-3200 Fax: +86-21-5027-3299

### RICOH COMPANY, LTD. Electronic Devices Company

● **Taipei office**  
Room109, 10F-1, No.51, Hengyang Rd., Taipei City, Taiwan (R.O.C.)  
Phone: +886-2-2313-1621/1622 Fax: +886-2-2313-1623



Ricoh completed the organization of the Lead-free production for all of our products. After Apr. 1, 2006, we will ship out the lead free products only. Thus, all products that will be shipped from now on comply with RoHS Directive.