

The R1215D Series are low supply current CMOS PWM step-up DC/DC controllers. R1215D does not include an internal output transistor. By simply using a power MOS, an inductor, a diode, resistors, and capacitors as external components, a high-efficiency step-up DC/DC converter can be easily configured. The oscillator maximum duty cycle and soft start time as well as phase compensation can be set with external resistors and capacitors (The oscillator maximum duty cycle does not include internal limit.) The oscillator frequency can be selected from 700kHz or 1.4MHz. The input voltage of R1215D is lower than the R1212D. The voltage range is 1.8V (2.0V) to 5.5V. The latch type protection circuit embedded into the device latches the external driver in the "OFF" state when the oscillator maximum duty cycle continues for a predetermined period of time setting by an external capacitor. R1215D also includes an under-voltage lockout circuit (UVLO).

FEATURES

- Supply Current (I_{DD1}).....Typ. 600 μ A (700kHz), Typ. 900 μ A (1.4MHz)
($V_{IN}=5.5V$, $V_{DLY}=V_{FB}=0V$, EXT at no load)
- Input Voltage Range (V_{IN})2.0V to 5.5V (A/B Version)
1.8V to 5.5V (E/F Version)
- Output Voltage RangeExternally adjustable (Feedback voltage : 1.0V)
- Feedback Voltage Accuracy $\pm 1.5\%$
- Temp. coeff. of Feedback Voltage ± 150 ppm/ $^{\circ}C$
- Oscillator Frequency (f_{osc}).....700kHz, 1.4MHz
- Oscillator Maximum Duty Cycle (Maxduty)Set with external resistors
- UVLO Detect Voltage (V_{UVLO})1.79V, 1.60V
- Soft Start Time (t_{start})Set with an external resistor and capacitor
- Package.....SON-8

BLOCK DIAGRAM

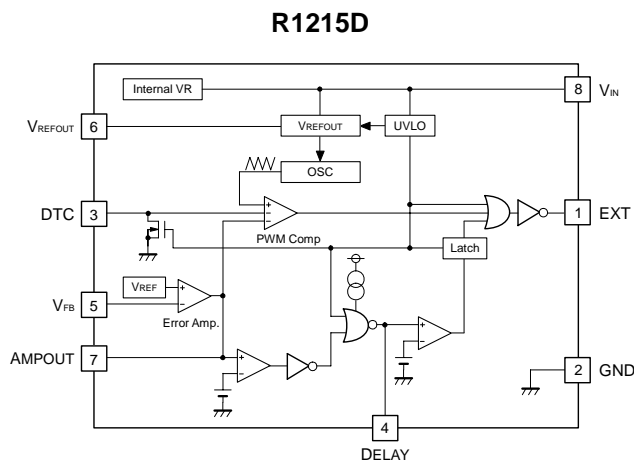

TYPICAL APPLICATION

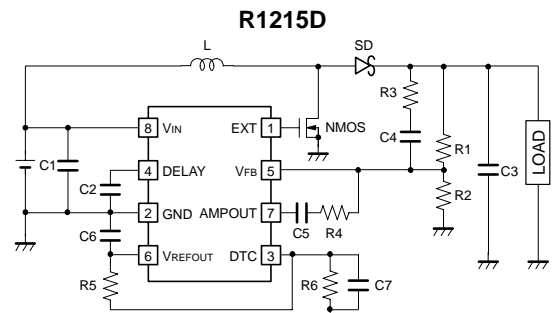

NMOS : CPH6415, L : VLP5612T (10 μ H), SD : CRS02, C1 : 1 μ F, C2 : 1 μ F, C3 : 15 μ F, C4 : 1000pF, C5 : 2200pF, C6 : 0.1 μ F, C7 : 0.1 μ F, R3 : 1k Ω , R4 : 4.7k Ω , R5 : 68k Ω , R6 : 240k Ω
Output voltage set value 9V...R1 : 160k Ω , R2 : 20k Ω

SELECTION GUIDE

Halogen Free	Package	Q'ty per Reel	Part No.
-	SON-8	3,000 pcs	R1215D002\$-TR-F

\$: Specify a combination of the oscillator frequency and UVLO detect voltage.

A : 700kHz, 1.79V, B : 1.4MHz, 1.79V,
E : 700kHz, 1.60V, F : 1.4MHz, 1.60V

PACKAGE

SON-8

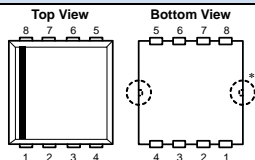

1	EXT	5	V _{FB}
2	GND	6	V _{REFOUT}
3	DTC	7	AMPOUT
4	DELAY	8	V _{IN}

*) The tab suspension leads are substrate level (GND).

TYPICAL CHARACTERISTIC

R1215D002E Efficiency vs. Output Current

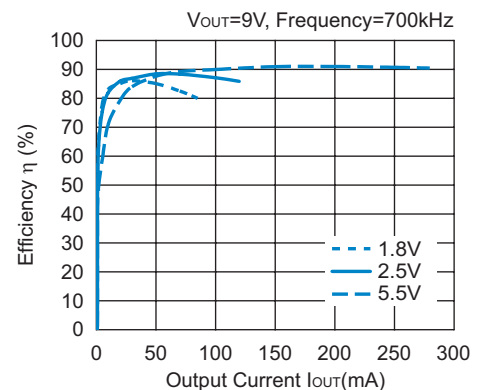

APPLICATIONS

- Power source for hand-held equipment
- Power source for LCD and CCD



1. The products and the product specifications described in this document are subject to change or discontinuation of production without notice for reasons such as improvement. Therefore, before deciding to use the products, please refer to Ricoh sales representatives for the latest information thereon.
2. The materials in this document may not be copied or otherwise reproduced in whole or in part without prior written consent of Ricoh.
3. Please be sure to take any necessary formalities under relevant laws or regulations before exporting or otherwise taking out of your country the products or the technical information described herein.
4. The technical information described in this document shows typical characteristics of and example application circuits for the products. The release of such information is not to be construed as a warranty of or a grant of license under Ricoh's or any third party's intellectual property rights or any other rights.
5. The products listed in this document are intended and designed for use as general electronic components in standard applications (office equipment, telecommunication equipment, measuring instruments, consumer electronic products, amusement equipment etc.). Those customers intending to use a product in an application requiring extreme quality and reliability, for example, in a highly specific application where the failure or misoperation of the product could result in human injury or death (aircraft, spacevehicle, nuclear reactor control system, traffic control system, automotive and transportation equipment, combustion equipment, safety devices, life support system etc.) should first contact us.
6. We are making our continuous effort to improve the quality and reliability of our products, but semiconductor products are likely to fail with certain probability. In order to prevent any injury to persons or damages to property resulting from such failure, customers should be careful enough to incorporate safety measures in their design, such as redundancy feature, firecontainment feature and fail-safe feature. We do not assume any liability or responsibility for any loss or damage arising from misuse or inappropriate use of the products.
7. Anti-radiation design is not implemented in the products described in this document.
8. Please contact Ricoh sales representatives should you have any questions or comments concerning the products or the technical information.

RICOH COMPANY., LTD. Electronic Devices Company



■ Ricoh presented with the Japan Management Quality Award for 1999.
Ricoh continually strives to promote customer satisfaction, and shares the achievements of its management quality improvement program with people and society.



■ Ricoh awarded ISO 14001 certification.
The Ricoh Group was awarded ISO 14001 certification, which is an international standard for environmental management systems, at both its domestic and overseas production facilities. Our current aim is to obtain ISO 14001 certification for all of our business offices.

<http://www.ricoh.com/LSI/>

RICOH COMPANY, LTD. Electronic Devices Company

● **Shin-Yokohama office (International Sales)**
3-2-3, Shin-Yokohama, Kohoku-ku, Yokohama City, Kanagawa 222-8530, Japan
Phone: +81-45-477-1697 Fax: +81-45-477-1698

RICOH EUROPE (NETHERLANDS) B.V.

● **Semiconductor Support Centre**
Prof. W.H.Keesomlaan 1, 1183 DL Amstelveen, The Netherlands
P.O.Box 114, 1180 AC Amstelveen
Phone: +31-20-5474-309 Fax: +31-20-5474-791

RICOH ELECTRONIC DEVICES KOREA Co., Ltd.

11 floor, Haesung 1 building, 942, Daechidong, Gangnamgu, Seoul, Korea
Phone: +82-2-2135-5700 Fax: +82-2-2135-5705

RICOH ELECTRONIC DEVICES SHANGHAI Co., Ltd.

Room403, No.2 Building, 690#Bi Bo Road, Pu Dong New district, Shanghai 201203,
People's Republic of China
Phone: +86-21-5027-3200 Fax: +86-21-5027-3299

RICOH COMPANY, LTD. Electronic Devices Company

● **Taipei office**
Room109, 10F-1, No.51, Hengyang Rd., Taipei City, Taiwan (R.O.C.)
Phone: +886-2-2313-1621/1622 Fax: +886-2-2313-1623



Ricoh completed the organization of the Lead-free production for all of our products. After Apr. 1, 2006, we will ship out the lead free products only. Thus, all products that will be shipped from now on comply with RoHS Directive.