STEP-UP DC/DC CONTROLLER

NO.EA-134-111123

OUTLINE

The R1215D Series are CMOS-based PWM step-up DC/DC converter controllers with low supply current.

Each of the R1215D Series consists of an oscillator, a PWM comparator circuit, a reference voltage unit, an error amplifier, a reference current unit, a protection circuit, and an under voltage lockout (UVLO) circuit. A low ripple, high efficiency step-up DC/DC converter can be composed of this IC with some external components, or an inductor, a diode, a power MOSFET, resistors, and capacitors.

Maximum duty cycle and the soft start time are easily adjustable with external resistors and capacitors. As for the protection circuit, after the soft-starting time, if the maximum duty cycle is continued for a certain period, the R1215D Series latch the external driver with its off state, or the latch-type protection circuit works.

The delay time for latch the state can be set with an external capacitor.

To release the protection circuit, restart with power-on (Voltage supplier is equal or less than UVLO detector threshold level).

FEATURES

- Input Voltage Range 1.8V to 5.5V
- Two Options of Basic Oscillator Frequency Typ.700kHz, 1.4MHz
- Built-in Latch-type Protection Function (Output Delay Time can be set with an external capacitor)
- Maximum Duty Cycle/Soft-start time Adjustable with external capacitors
- High Reference Voltage Accuracy $\pm 1.5\%$
- UVLO Threshold level Typ.1.6V/1.79V by mask option
- Small Temperature Coefficient of Reference Voltage ... Typ. $\pm 150\text{ppm}/^\circ\text{C}$
- Package SON-8 (t = Max. 0.9mm)

APPLICATIONS

- Constant Voltage Power Source for portable equipment.
- Constant Voltage Power Source for LCD and CCD.

BLOCK DIAGRAM

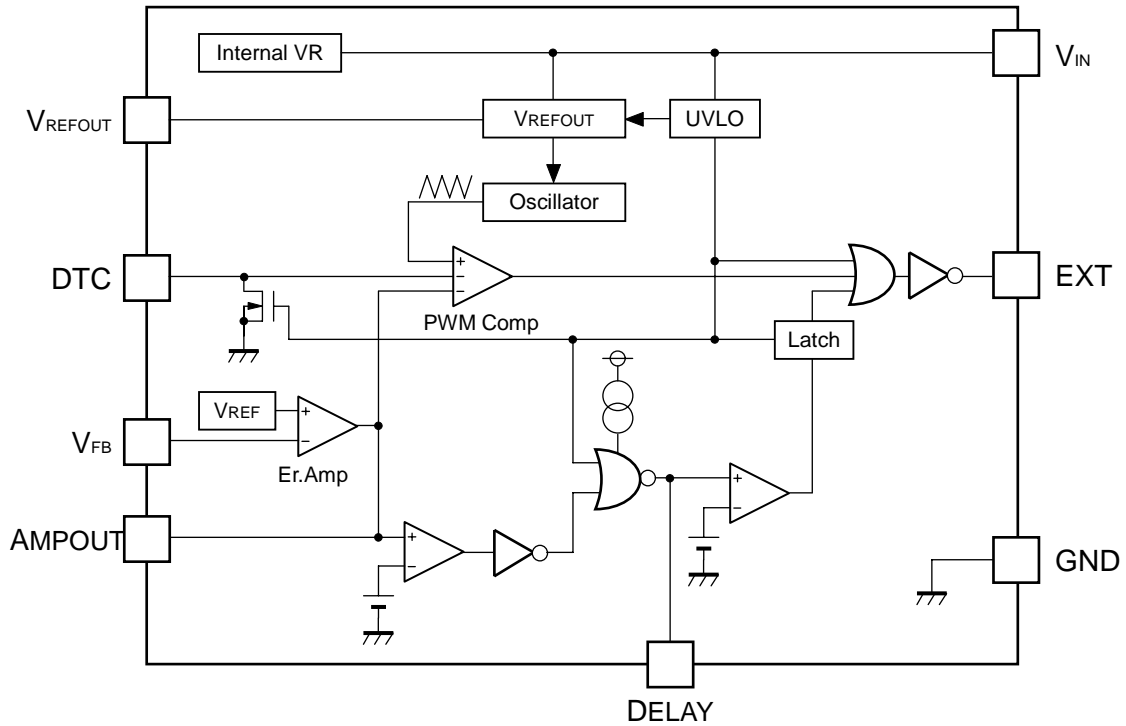

SELECTION GUIDE

In the R1215D Series, the oscillator frequency and UVLO detector threshold can be selected at the user's request.

Product Name	Package	Quantity per Reel	Pb Free	Halogen Free
R1215D002x-TR-F	SON-8	3,000 pcs	○	—

x : Designation of Oscillator Frequency and Detector Threshold

Code	Oscillator Frequency	UVLO Detector Threshold
A	TYP. 700kHz	TYP. 1.79V
B	TYP. 1.4MHz	TYP. 1.79V
E	TYP. 700kHz	TYP. 1.60V
F	TYP. 1.4MHz	TYP. 1.60V

PIN CONFIGURATION

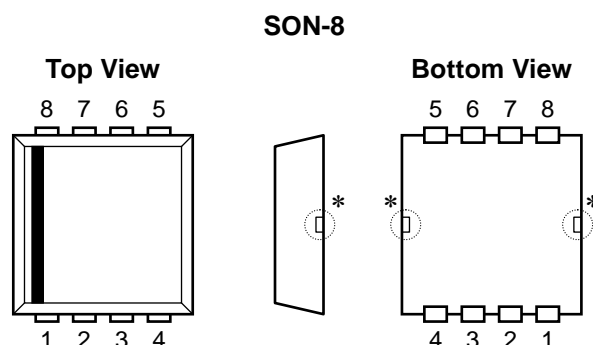

PIN DESCRIPTION

Pin No	Symbol	Description
1	EXT	External FET Drive Pin (CMOS Output)
2	GND	Ground Pin
3	DTC	Pin for Setting Maximum Duty Cycle and Soft start time
4	DELAY	Pin for External Capacitor (for Setting Output Delay of Protection)
5	V_{FB}	Feedback Pin for monitoring Output Voltage
6	V_{REFOUT}	Reference Voltage Output Pin
7	AMPOUT	Amplifier Output Pin
8	V_{IN}	Power Supply Pin for the IC

* Tab suspension leads in the  parts have GND level. (They are connected to the reverse side of this IC.)
Do not connect to other wires or land patterns.

ABSOLUTE MAXIMUM RATINGS

(GND=0V)

Symbol	Item	Rating	Unit
V_{IN}	V_{IN} Pin Voltage	6.5	V
V_{EXT}	EXT Pin Output Voltage	-0.3 to $V_{IN}+0.3$	V
V_{DLY}	DELAY Pin Voltage	-0.3 to $V_{IN}+0.3$	V
V_{REFOUT}	V_{REFOUT} Pin Voltage	-0.3 to $V_{IN}+0.3$	V
V_{AMP}	AMPOUT Pin Voltage	-0.3 to $V_{IN}+0.3$	V
V_{DTC}	DTC Pin Voltage	-0.3 to $V_{IN}+0.3$	V
V_{FB}	V_{FB} Pin Voltage	-0.3 to $V_{IN}+0.3$	V
I_{AMP}	AMPOUT Pin Current	± 10	mA
I_{ROUT}	V_{REFOUT} Pin Current	30	mA
I_{EXT}	EXT Pin Inductor Drive Output Current	± 80	mA
P_D	Power Dissipation	480	mW
T_{opt}	Operating Temperature Range	-40 to +85	$^{\circ}C$
T_{stg}	Storage Temperature Range	-55 to +125	$^{\circ}C$

*1 For Power Dissipation, please refer to PACKAGE INFORMATION to be described.

ELECTRICAL CHARACTERISTICS

• R1215D002A

T_{opt}=25°C

Symbol	Item	Conditions	Min.	Typ.	Max.	Unit
V _{IN}	Operating Input Voltage		2.0		5.5	V
V _{FB}	V _{FB} Voltage Tolerance	V _{IN} =2.5V	0.985	1.000	1.015	V
ΔV _{FB} /ΔV _{IN}	V _{FB} Voltage Line Regulation	V _{IN} : from 2.0V to 5.5V		3		mV
ΔV _{FB} /ΔT _{opt}	V _{FB} Voltage Temperature Coefficient	-40°C ≤ T _{opt} ≤ 85°C		±150		ppm/°C
I _{FB}	V _{FB} Input Current	V _{IN} =5.5V, V _{FB} =0V or 5.5V	-0.1	0	0.1	μA
A _v	Open Loop Voltage Gain	V _{IN} =2.5V		100		dB
f _r	Unity Gain Frequency Band	V _{IN} =2.5V, A _v =0		1.0		MHz
f _{osc}	Oscillator Frequency	V _{IN} =2.5V, V _{DLY} =V _{FB} =0V	595	700	805	kHz
Δf _{osc} /ΔV _{IN}	Oscillator Frequency Line Regulation	V _{IN} : from 2.0V to 5.5V		50		kHz
Δf _{osc} /ΔT _{opt}	Oscillator Frequency Temperature Coefficient	-40°C ≤ T _{opt} ≤ 85°C		±0.3		kHz/°C
I _{DD1}	Supply Current 1	V _{IN} =5.5V, V _{DLY} =V _{FB} =0V		600	1000	μA
V _{REFOUT}	V _{REFOUT} Voltage	V _{IN} =2.5V, I _{ROUT} =1mA	1.280	1.300	1.320	V
I _{OUT}	V _{REFOUT} Maximum Output Current	V _{IN} =2.5V	10			mA
ΔV _{REFOUT} /ΔV _{IN}	V _{REFOUT} Line Regulation	V _{IN} : from 2.0V to 5.5V		5	10	mV
ΔV _{REFOUT} /ΔI _{ROUT}	V _{REFOUT} Load Regulation	V _{IN} =2.5V, I _{ROUT} : from 0.1mA to 5.0mA		6	20	mV
I _{LIM}	V _{REFOUT} Short Current Limit	V _{IN} =2.5V, V _{REFOUT} =0V		15		mA
ΔV _{REFOUT} /ΔT _{opt}	V _{REFOUT} Voltage Temperature Coefficient	-40°C ≤ T _{opt} ≤ 85°C		±150		ppm/°C
R _{EXTH}	EXT "H" ON Resistance	V _{IN} =2.5V, I _{EXT} =-50mA		2.8	6.0	Ω
R _{EXTL}	EXT "L" ON Resistance	V _{IN} =2.5V, I _{EXT} =50mA		1.8	4.0	Ω
t _r	EXT Rising Time	V _{IN} =2.5V, C _{EXT} =1000pF		12		ns
t _f	EXT Falling Time	V _{IN} =2.5V, C _{EXT} =1000pF		8		ns
I _{DLY1}	DELAY Pin Charge Current	V _{IN} =2.5V, V _{DLY} =V _{FB} =0V	3.0	6.0	8.5	μA
I _{DLY2}	DELAY Pin Discharge Current	V _{IN} =V _{FB} =2.0V, V _{DLY} =0.1V	0.08	0.20	0.36	mA
V _{DLY}	DELAY Pin Detector Threshold	V _{IN} =2.5V, V _{FB} =0V, V _{DLY} =0V to 2V	0.95	1.00	1.05	V
V _{UVLO1}	UVLO Detector Threshold	V _{IN} =2.5V to 0V, V _{DLY} =V _{FB} =0V	1.70	1.79	1.88	V
V _{UVLO2}	UVLO Released Voltage	V _{IN} =0V to 2.5V, V _{DLY} =V _{FB} =0V	1.78	1.88	1.98	V
V _{HYS}	UVLO Hysteresis Range		0.04	0.09	0.14	V
V _{DTC0}	Duty=0% DTC Pin Voltage	V _{IN} =2.5V	0.28	0.38	0.48	V
V _{DTC20}	Duty=20% DTC Pin Voltage	V _{IN} =2.5V		0.48		V
V _{DTC80}	Duty=80% DTC Pin Voltage	V _{IN} =2.5V		0.92		V
V _{DTC100}	Duty=100% DTC Pin Voltage	V _{IN} =2.5V	0.92	1.02	1.12	V
I _{AMPH}	AMP "H" Output Current	V _{IN} =2.5V, V _{AMP} =1.0V, V _{FB} =0.9V	1.6	3.2	5.8	mA
I _{AMPL}	AMP "L" Output Current	V _{IN} =2.5V, V _{AMP} =1.0V, V _{FB} =1.1V	40	85	130	μA

● R1215D002B

T_{opt}=25°C

Symbol	Item	Conditions	Min.	Typ.	Max.	Unit
V _{IN}	Operating Input Voltage		2.0		5.5	V
V _{FB}	V _{FB} Voltage Tolerance	V _{IN} =2.5V	0.985	1.000	1.015	V
$\Delta V_{FB}/\Delta V_{IN}$	V _{FB} Voltage Line Regulation	V _{IN} : from 2.0V to 5.5V		3		mV
$\Delta V_{FB}/\Delta T_{opt}$	V _{FB} Voltage Temperature Coefficient	-40°C ≤ T _{opt} ≤ 85°C		±150		ppm/°C
I _{FB}	V _{FB} Input Current	V _{IN} =5.5V, V _{FB} =0V or 5.5V	-0.1	0	0.1	μA
A _v	Open Loop Voltage Gain	V _{IN} =2.5V		100		dB
f _r	Unity Gain Frequency Band	V _{IN} =2.5V, A _v =0		1.0		MHz
f _{osc}	Oscillator Frequency	V _{IN} =2.5V, V _{DLY} =V _{FB} =0V	1.190	1.400	1.610	MHz
$\Delta f_{osc}/\Delta V_{IN}$	Oscillator Frequency Line Regulation	V _{IN} : from 2.0V to 5.5V		100		kHz
$\Delta f_{osc}/\Delta T_{opt}$	Oscillator Frequency Temperature Coefficient	-40°C ≤ T _{opt} ≤ 85°C		±0.6		kHz/°C
I _{DD1}	Supply Current 1	V _{IN} =5.5V, V _{DLY} =V _{FB} =0V		900	1800	μA
V _{REFOUT}	V _{REFOUT} Voltage	V _{IN} =2.5V, I _{ROUT} =1mA	1.280	1.300	1.320	V
I _{OUT}	V _{REFOUT} Maximum Output Current	V _{IN} =2.5V	10			mA
$\Delta V_{REFOUT}/\Delta V_{IN}$	V _{REFOUT} Line Regulation	V _{IN} : from 2.0V to 5.5V		5	10	mV
$\Delta V_{REFOUT}/\Delta I_{ROUT}$	V _{REFOUT} Load Regulation	V _{IN} =2.5V, I _{ROUT} : from 0.1mA to 5.0mA		6	20	mV
I _{LIM}	V _{REFOUT} Short Current Limit	V _{IN} =2.5V, V _{REFOUT} =0V		15		mA
$\Delta V_{REFOUT}/\Delta T_{opt}$	V _{REFOUT} Voltage Temperature Coefficient	-40°C ≤ T _{opt} ≤ 85°C		±150		ppm/°C
R _{EXTH}	EXT "H" ON Resistance	V _{IN} =2.5V, I _{EXT} =-50mA		2.8	6.0	Ω
R _{EXTL}	EXT "L" ON Resistance	V _{IN} =2.5V, I _{EXT} =50mA		1.8	4.0	Ω
t _r	EXT Rising Time	V _{IN} =2.5V, C _{EXT} =1000pF		12		ns
t _f	EXT Falling Time	V _{IN} =2.5V, C _{EXT} =1000pF		8		ns
I _{DLY1}	DELAY Pin Charge Current	V _{IN} =2.5V, V _{DLY} =V _{FB} =0V	3.0	6.0	8.5	μA
I _{DLY2}	DELAY Pin Discharge Current	V _{IN} =V _{FB} =2.0V, V _{DLY} =0.1V	0.08	0.20	0.36	mA
V _{DLY}	DELAY Pin Detector Threshold	V _{IN} =2.5V, V _{FB} =0V, V _{DLY} =0V to 2V	0.95	1.00	1.05	V
V _{UVLO1}	UVLO Detector Threshold	V _{IN} =2.5V to 0V, V _{DLY} =V _{FB} =0V	1.70	1.79	1.88	V
V _{UVLO2}	UVLO Released Voltage	V _{IN} =0V to 2.5V, V _{DLY} =V _{FB} =0V	1.78	1.88	1.98	V
V _{HYS}	UVLO Hysteresis Range		0.04	0.09	0.14	V
V _{DTC0}	Duty=0% DTC Pin Voltage	V _{IN} =2.5V	0.28	0.38	0.48	V
V _{DTC20}	Duty=20% DTC Pin Voltage	V _{IN} =2.5V		0.47		V
V _{DTC80}	Duty=80% DTC Pin Voltage	V _{IN} =2.5V		0.93		V
V _{DTC100}	Duty=100% DTC Pin Voltage	V _{IN} =2.5V	0.92	1.02	1.12	V
I _{AMPH}	AMP "H" Output Current	V _{IN} =2.5V, V _{AMP} =1.0V, V _{FB} =0.9V	1.6	3.2	5.8	mA
I _{AMPL}	AMP "L" Output Current	V _{IN} =2.5V, V _{AMP} =1.0V, V _{FB} =1.1V	40	85	130	μA

R1215D

• R1215D002E

T_{opt}=25°C

Symbol	Item	Conditions	Min.	Typ.	Max.	Unit
V _{IN}	Operating Input Voltage		1.8		5.5	V
V _{FB}	V _{FB} Voltage Tolerance	V _{IN} =2.5V	0.985	1.000	1.015	V
$\Delta V_{FB}/\Delta V_{IN}$	V _{FB} Voltage Line Regulation	V _{IN} : from 1.8 V to 5.5V		3		mV
$\Delta V_{FB}/\Delta T_{opt}$	V _{FB} Voltage Temperature Coefficient	-40°C ≤ T _{opt} ≤ 85°C		±150		ppm/°C
I _{FB}	V _{FB} Input Current	V _{IN} =5.5V, V _{FB} =0V or 5.5V	-0.1	0	0.1	μA
A _V	Open Loop Voltage Gain	V _{IN} =2.5V		100		dB
f _T	Unity Gain Frequency Band	V _{IN} =2.5V, A _V =0		1.0		MHz
f _{osc}	Oscillator Frequency	V _{IN} =2.5V, V _{DLY} =V _{FB} =0V	595	700	805	kHz
$\Delta f_{osc}/\Delta V_{IN}$	Oscillator Frequency Line Regulation	V _{IN} : from 1.8V to 5.5V		50		kHz
$\Delta f_{osc}/\Delta T_{opt}$	Oscillator Frequency Temperature Coefficient	-40°C ≤ T _{opt} ≤ 85°C		±0.3		kHz/°C
I _{DD1}	Supply Current 1	V _{IN} =5.5V, V _{DLY} =V _{FB} =0V		600	1000	μA
V _{REFOUT}	V _{REFOUT} Voltage	V _{IN} =2.5V, I _{ROUT} =1mA	1.280	1.300	1.320	V
I _{OUT}	V _{REFOUT} Maximum Output Current	V _{IN} =2.5V	10			mA
$\Delta V_{REFOUT}/\Delta V_{IN}$	V _{REFOUT} Line Regulation	V _{IN} : from 1.8V to 5.5V		5	10	mV
$\Delta V_{REFOUT}/\Delta I_{ROUT}$	V _{REFOUT} Load Regulation	V _{IN} =2.5V, I _{ROUT} : from 0.1mA to 5.0mA		6	20	mV
I _{LIM}	V _{REFOUT} Short Current Limit	V _{IN} =2.5V, V _{REFOUT} =0V		15		mA
$\Delta V_{REFOUT}/\Delta T_{opt}$	V _{REFOUT} Voltage Temperature Coefficient	-40°C ≤ T _{opt} ≤ 85°C		±150		ppm/°C
R _{EXTH}	EXT "H" ON Resistance	V _{IN} =2.5V, I _{EXT} =-50mA		2.8	6.0	Ω
R _{EXTL}	EXT "L" ON Resistance	V _{IN} =2.5V, I _{EXT} =50mA		1.8	4.0	Ω
t _r	EXT Rising Time	V _{IN} =2.5V, C _{EXT} =1000pF		12		ns
t _f	EXT Falling Time	V _{IN} =2.5V, C _{EXT} =1000pF		8		ns
I _{DLY1}	DELAY Pin Charge Current	V _{IN} =2.5V, V _{DLY} =V _{FB} =0V	3.0	6.0	8.5	μA
I _{DLY2}	DELAY Pin Discharge Current	V _{IN} =V _{FB} =1.8V, V _{DLY} =0.1V	0.08	0.18	0.36	mA
V _{DLY}	DELAY Pin Detector Threshold	V _{IN} =2.5V, V _{FB} =0V, V _{DLY} =0V to 2V	0.95	1.00	1.05	V
V _{UVLO1}	UVLO Detector Threshold	V _{IN} =2.5V to 0V, V _{DLY} =V _{FB} =0V	1.50	1.60	1.70	V
V _{UVLO2}	UVLO Released Voltage	V _{IN} =0V to 2.5V, V _{DLY} =V _{FB} =0V	1.56	1.67	1.78	V
V _{HYS}	UVLO Hysteresis Range		0.03	0.07	0.11	V
V _{DTC0}	Duty=0% DTC Pin Voltage	V _{IN} =2.5V	0.28	0.38	0.48	V
V _{DTC20}	Duty=20% DTC Pin Voltage	V _{IN} =2.5V		0.48		V
V _{DTC80}	Duty=80% DTC Pin Voltage	V _{IN} =2.5V		0.92		V
V _{DTC100}	Duty=100% DTC Pin Voltage	V _{IN} =2.5V	0.92	1.02	1.12	V
I _{AMPH}	AMP "H" Output Current	V _{IN} =2.5V, V _{AMP} =1.0V, V _{FB} =0.9V	1.6	3.2	5.8	mA
I _{AMPL}	AMP "L" Output Current	V _{IN} =2.5V, V _{AMP} =1.0V, V _{FB} =1.1V	40	85	130	μA

● R1215D002F

T_{opt}=25°C

Symbol	Item	Conditions	Min.	Typ.	Max.	Unit
V _{IN}	Operating Input Voltage		1.8		5.5	V
V _{FB}	V _{FB} Voltage Tolerance	V _{IN} =2.5V	0.985	1.000	1.015	V
$\Delta V_{FB}/\Delta V_{IN}$	V _{FB} Voltage Line Regulation	V _{IN} : from 1.8V to 5.5V		3		mV
$\Delta V_{FB}/\Delta T_{opt}$	V _{FB} Voltage Temperature Coefficient	-40°C ≤ T _{opt} ≤ 85°C		±150		ppm/°C
I _{FB}	V _{FB} Input Current	V _{IN} =5.5V, V _{FB} =0V or 5.5V	-0.1	0	0.1	μA
A _v	Open Loop Voltage Gain	V _{IN} =2.5V		100		dB
f _r	Unity Gain Frequency Band	V _{IN} =2.5V, A _v =0		1.0		MHz
f _{osc}	Oscillator Frequency	V _{IN} =2.5V, V _{DLY} =V _{FB} =0V	1.190	1.400	1.610	MHz
$\Delta f_{osc}/\Delta V_{IN}$	Oscillator Frequency Line Regulation	V _{IN} : from 1.8V to 5.5V		100		KHz
$\Delta f_{osc}/\Delta T_{opt}$	Oscillator Frequency Temperature Coefficient	-40°C ≤ T _{opt} ≤ 85°C		±0.6		KHz/°C
I _{DD1}	Supply Current 1	V _{IN} =5.5V, V _{DLY} =V _{FB} =0V		900	1800	μA
V _{REFOUT}	V _{REFOUT} Voltage	V _{IN} =2.5V, I _{ROUT} =1mA	1.280	1.300	1.320	V
I _{OUT}	V _{REFOUT} Maximum Output Current	V _{IN} =2.5V	10			mA
$\Delta V_{REFOUT}/\Delta V_{IN}$	V _{REFOUT} Line Regulation	V _{IN} : from 1.8V to 5.5V		5	10	mV
$\Delta V_{REFOUT}/\Delta I_{ROUT}$	V _{REFOUT} Load Regulation	V _{IN} =2.5V, I _{ROUT} : from 0.1mA to 5.0mA		6	20	mV
I _{LIM}	V _{REFOUT} Short Current Limit	V _{IN} =2.5V, V _{REFOUT} =0V		15		mA
$\Delta V_{REFOUT}/\Delta T_{opt}$	V _{REFOUT} Voltage Temperature Coefficient	-40°C ≤ T _{opt} ≤ 85°C		±150		ppm/°C
R _{EXTH}	EXT "H" ON Resistance	V _{IN} =2.5V, I _{EXT} =-50mA		2.8	6.0	Ω
R _{EXTL}	EXT "L" ON Resistance	V _{IN} =2.5V, I _{EXT} =50mA		1.8	4.0	Ω
t _r	EXT Rising Time	V _{IN} =2.5V, C _{EXT} =1000pF		12		ns
t _f	EXT Falling Time	V _{IN} =2.5V, C _{EXT} =1000pF		8		ns
I _{DLY1}	DELAY Pin Charge Current	V _{IN} =2.5V, V _{DLY} =V _{FB} =0V	3.0	6.0	8.5	μA
I _{DLY2}	DELAY Pin Discharge Current	V _{IN} =V _{FB} =1.8V, V _{DLY} =0.1V	0.08	0.18	0.36	mA
V _{DLY}	DELAY Pin Detector Threshold	V _{IN} =2.5V, V _{FB} =0V, V _{DLY} =0V to 2V	0.95	1.00	1.05	V
V _{UVLO1}	UVLO Detector Threshold	V _{IN} =2.5V to 0V, V _{DLY} =V _{FB} =0V	1.50	1.60	1.70	V
V _{UVLO2}	UVLO Released Voltage	V _{IN} =0V to 2.5V, V _{DLY} =V _{FB} =0V	1.56	1.67	1.78	V
V _{HYS}	UVLO Hysteresis Range		0.03	0.07	0.11	V
V _{DTC0}	Duty=0% DTC Pin Voltage	V _{IN} =2.5V	0.28	0.38	0.48	V
V _{DTC20}	Duty=20% DTC Pin Voltage	V _{IN} =2.5V		0.47		V
V _{DTC80}	Duty=80% DTC Pin Voltage	V _{IN} =2.5V		0.93		V
V _{DTC100}	Duty=100% DTC Pin Voltage	V _{IN} =2.5V	0.92	1.02	1.12	V
I _{AMPH}	AMP "H" Output Current	V _{IN} =2.5V, V _{AMP} =1.0V, V _{FB} =0.9V	1.6	3.2	5.8	mA
I _{AMPL}	AMP "L" Output Current	V _{IN} =2.5V, V _{AMP} =1.0V, V _{FB} =1.1V	40	85	130	μA

TYPICAL APPLICATIONS AND TECHNICAL NOTES

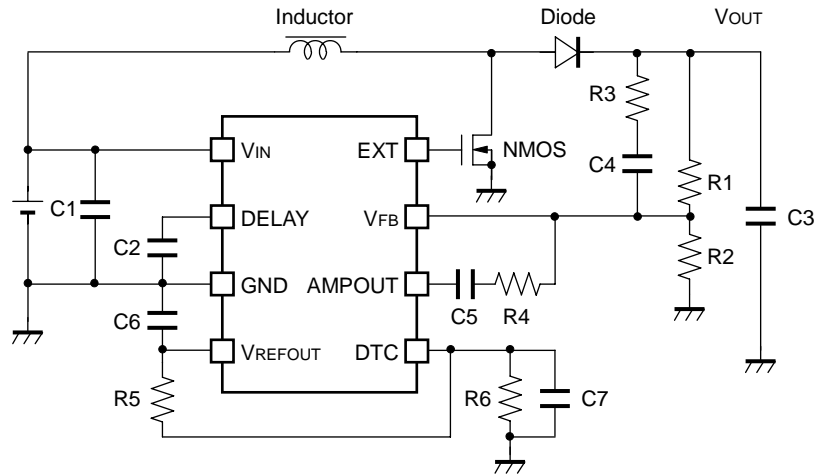

Inductor	LDR655312T-100 (TDK)		
NMOS	CPH6415 (Sanyo)		
Diode	CRS02 (Toshiba)		
C1	1.0 μ F	R1	160k Ω
C2	1.0 μ F	R2	20k Ω
C3	15 μ F	R3	1k Ω
C4	1000pF	R4	4.7k Ω
C5	2200pF	R5	68k Ω
C6	1.0 μ F	R6	240k Ω
C7	1.0 μ F		

Use a 1 μ F or more capacitance value of bypass capacitor between V_{IN} pin and GND, C1 as shown in the typical application above. Connect the capacitor as short as possible to the IC.

- In terms of the capacitor for setting delay time of the latch protection, C2 is shown in typical application above. Latch delay time depends on this C2 value. Refer to the Latch Protection Operation Timing Chart. Set the C2 GND as close as possible to the IC GND.
- Connect a 1 μ F or more value of capacitor between V_{OUT} and GND, C3 as shown in typical application above. (10 μ F to 22 μ F is the capacitance recommendation range.) If the operation of the composed DC/DC converter may be unstable, use a tantalum type capacitor instead of ceramic type
- Connect a capacitor between V_{REFOUT} and GND, C6 as shown in typical application of the previous page. The capacitance value of C6 is between 0.1 μ F and 1.0 μ F.

• Output Voltage Setting Method and Phase Compensation Making Method

- The feedback voltage is controlled into 1.0V. The output voltage can be set with divider resistors for voltage setting, R1 and R2 as shown in typical application of the previous page. Refer to the next formula.

$$\text{Output Voltage} = V_{FB} \times (R1+R2)/R2$$

Output Voltage is adjustable with setting various resistor values combination.

R1+R2 should be equal or less than 500kΩ

As for the DC/DC converter, depending on the load current and external components such as L and C, phase may loss around 180°. In such case, phase margin becomes less and may be unstable. To avoid this situation, make the phase margin more. The pole is made with external components L and C.

$$F_{\text{pole}} \sim 1 / \{ 2 \times \pi \times \sqrt{L \times C3} \}$$

C4, C5, R3, and R4 shown in the diagram are for making phase compensation. The gain of the system can be set with using these resistors and capacitors. Each value in the diagram is just an example.

R4 and C5 make zero (the backward phase).

$$F_{\text{zero}} \sim 1 / (2 \times \pi \times R4 \times C5)$$

Choose the R4 and C5 value so as to make the cutoff frequency of this zero point close to the cutoff frequency of the pole by external components, L and C.

For example, supposed that L=10μH and C_{OUT} (C3) =15μF, the cutoff frequency of the pole is approximately 13kHz. Therefore make the cutoff frequency of the zero point close to 13kHz. Then R4=4.7kΩ and C5=2200pF are appropriate values.

As for setting the gain, the ratio of the composite resistor (RT: RT=R1×R2/(R1+R2)) to R4 is the key.

If the R4 against the composite resistor, R_T, is large, the gain becomes also large. If the gain is large, the response characteristic is improved, however, too large gain makes the system be unstable.

If the spike noise of V_{OUT} may be large, the spike noise may be picked into V_{FB} pin, and the unstable operation may result. In this case, a resistor R3, shown in typical application of the previous page. The recommended resistance value of R3 is in the range from 1kΩ to 5kΩ. Then, noise level will be decreased.

Further, R1 and C4 makes another zero point (the backward phase).

$$F_{\text{zero}} \sim 1 / (2 \times \pi \times R1 \times C4)$$

Make the cutoff frequency of this zero point be lower than the cutoff frequency of the pole by external components, or, L and C. Herein, R1=160kΩ and C4=1000pF are appropriate values.

- Select the Power MOSFET, the diode, capacitors and the inductor within ratings (Voltage, Current, Power) of this IC. Choose the power MOSFET with low threshold voltage depending on the input voltage to be able to turn on the FET completely. Choose the diode with low V_F such as Schottky type with low reverse current I_R, and with fast switching speed. When an external transistor is switching, spike voltage may be generated caused by an inductor, therefore recommended voltage tolerance of capacitor connected to V_{OUT} is twice as much as the setting voltage or more.
- The soft-start time and the maximum duty cycle setting method
The soft-start time and the maximum duty cycle can be set with R5, R6, and C7 values connected to the V_{REFOUT} pin and the DTC pin. (Refer to the timing chart: Soft-start operation.)

Output Current and Selection of External Components

<Basic Circuit>

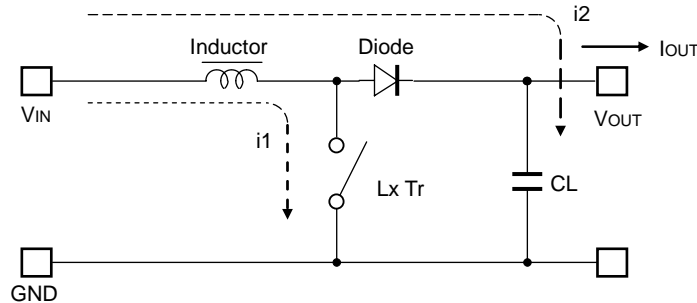

<Circuit through L>

Discontinuous Mode

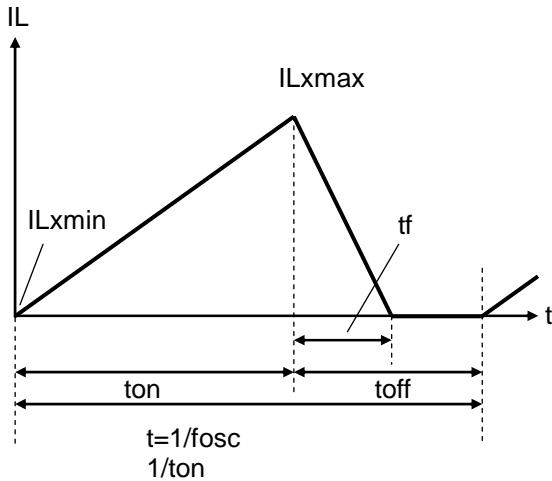

Continuous Mode

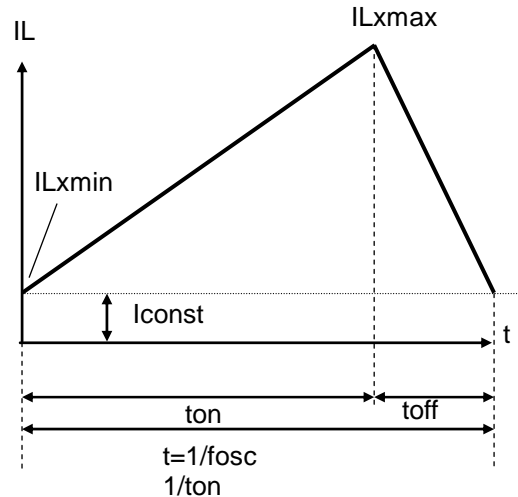

There are two modes, or discontinuous mode and continuous mode for the PWM step-up switching regulator depending on the continuous characteristic of inductor current.

During on time of the transistor, when the voltage added on to the inductor is described as V_{IN} , the current is $V_{IN} \times t/L$. Therefore, the electric power, P_{ON} , which is supplied with input side, can be described as in next formula.

$$P_{ON} = \int_0^{ton} V_{IN}^2 \times t/L dt \dots\dots\dots \text{Formula 1}$$

With the step-up circuit, electric power is supplied from power source also during off time. In this case, input current is described as $(V_{OUT} - V_{IN}) \times t/L$, therefore electric power, P_{OFF} is described as in next formula.

$$P_{OFF} = \int_0^{toff} V_{IN} \times (V_{OUT} - V_{IN}) \times t/L dt \dots\dots\dots \text{Formula 2}$$

In this formula, T_f means the time of which the energy saved in the inductance is being emitted. Thus average electric power, or P_{AV} is described as in the next formula.

$$P_{AV} = 1/(ton + toff) \times \left\{ \int_0^{ton} V_{IN}^2 \times t/L dt + \int_0^{toff} V_{IN} \times (V_{OUT} - V_{IN}) \times t/L dt \right\} \dots\dots\dots \text{Formula 3}$$

In PWM control, when $t_f = t_{off}$ is true, the inductor current becomes continuous, then the operation of switching regulator becomes continuous mode.

In the continuous mode, the deviation of the current is equal between on time and off time.

$$V_{IN} = t_{ON} / L = (V_{OUT} - V_{IN}) \times t_{OFF} / L \dots\dots\dots \text{Formula 4}$$

Further, the electric power, P_{AV} is equal to output electric power, $V_{OUT} \times I_{OUT}$, thus,

$$I_{OUT} = f_{OSC} \times V_{IN}^2 \times t_{ON}^2 / \{2 \times L \times (V_{OUT} - V_{IN})\} = V_{IN}^2 \times t_{ON} / (2 \times L \times V_{OUT}) \dots\dots\dots \text{Formula 5}$$

When I_{OUT} becomes more than formula 5, the current flows through the inductor, then the mode becomes continuous. The continuous current through the inductor is described as I_{const} , then,

$$I_{OUT} = f_{OSC} \times V_{IN}^2 \times t_{ON}^2 / \{2 \times L \times (V_{OUT} - V_{IN})\} + V_{IN} \times I_{const} / V_{OUT} \dots\dots\dots \text{Formula 6}$$

In this moment, the peak current, I_{Lxmax} flowing through the inductor and the driver Tr . is described as follows:

$$I_{Lx \max} = I_{const} + V_{IN} \times t_{ON} / L \dots\dots\dots \text{Formula 7}$$

With the formula 4,6, and I_{Lxmax} is,

$$I_{Lx \max} = V_{OUT} / V_{IN} \times I_{OUT} + V_{IN} \times t_{ON} / (2 \times L) \dots\dots\dots \text{Formula 8}$$

Therefore, peak current is more than I_{OUT} . Considering the value of I_{Lxmax} , the condition of input and output, and external components should be selected.

In the formula 7, peak current I_{Lxmax} at discontinuous mode can be calculated. Put $I_{const}=0$ in the formula.

The explanation above is based on the ideal calculation, and the loss caused by L_x switch and external components is not included. The actual maximum output current is between 50% and 80% of the calculation. Especially, when the I_{Lx} is large, or V_{IN} is low, the loss of V_{IN} is generated with the on resistance of the switch. As for V_{OUT} , V_f (as much as 0.3V) of the diode should be considered.

TIMING CHART

<Soft-start Operation>

The timing chart below describes the state of each pin from the power-on until the IC entering the stable operation.

By raising the voltage of the DTC pin slowly, the switching duty cycle is limited, and prevent the drastic voltage rising (over-shoot) and inrush current.

When the V_{IN} voltage becomes equal or more than the UVLO released voltage ($V_{UVLO}+V_{HYS}$), V_{REFOUT} operation starts. Following with the increase of the voltage level of V_{REFOUT} , the internal oscillator begins to operate, then the DTC voltage is also rising, then, soft-start operation starts. When the DTC voltage crosses the chopping wave level inside the IC, EXT pin starts switching, then, step-up operation begins. During this term, the output voltage does not reach the set output voltage. Therefore the output of the amplifier is "H". Besides, the protection circuit may work and the IC charges the DELAY pin. Because of this, the soft-start time should be set shorter than the latch protection delay time.

After the initial stage, when the output voltage reaches the set output voltage, the level of AMP_{OUT} becomes the normal state. In other words, the level is determined with the input voltage, the output voltage, and the output current. When the level of AMP_{OUT} becomes falling, charging the DELAY pin stops and discharges to the GND. The soft-start time (the time for the DTC pin voltage becoming to V_{DTC} level) can be estimated with the next formula.

$$t \cong 1/\alpha \times \ln(V_{DTC} \times \alpha / \beta + 1), \text{ herein, } \alpha = -1/C7 \times (1/R5 + 1/R6), \text{ and } \beta = V_{REFOUT} / (C7 \times R5).$$

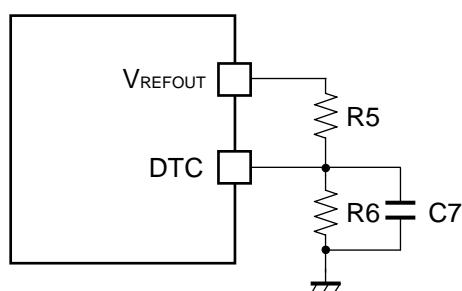
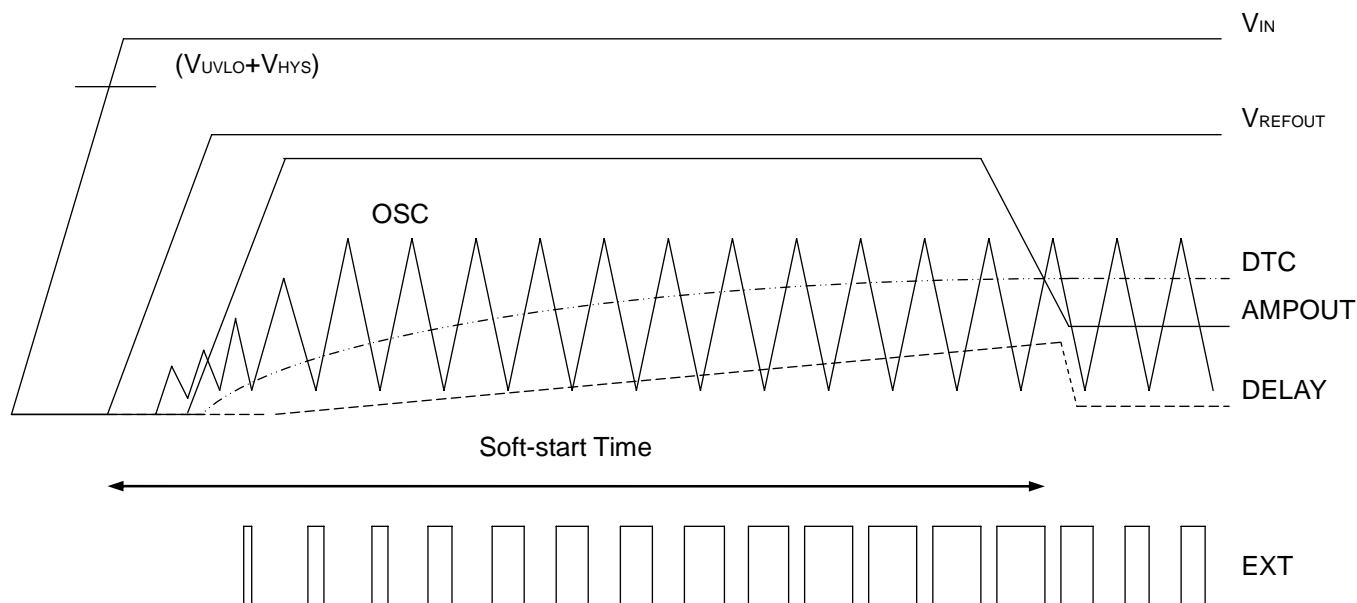

<Latch Protection Operation>

The operation of Latch protection circuit is as follows: When AMPOUT becomes "H" and the IC detects maximum duty cycle, charge to an external capacitor, C2 of DELAY pin starts. The maximum duty cycle continues and the voltage of DELAY pin reaches delay voltage detector threshold, V_{DLY} , outputs "L" to EXT pin and turns off the external power MOSFET.

To release the latch protection operation, make the supply voltage down to UVLO detector threshold or lower, and make it rise up to the normal input voltage.

Once after becoming the maximum duty cycle, if the duty cycle decreases before latch operation works, the charging the capacitor stops immediately, and the DELAY pin voltage is fixed at GND level with I_{DLY2} .

The delay time of latch protection can be calculated with C2, V_{DLY} , and the delay pin charge current, I_{DLY1} , as in the next formula.

$$t = C2 \times V_{DLY} / I_{DLY1}$$

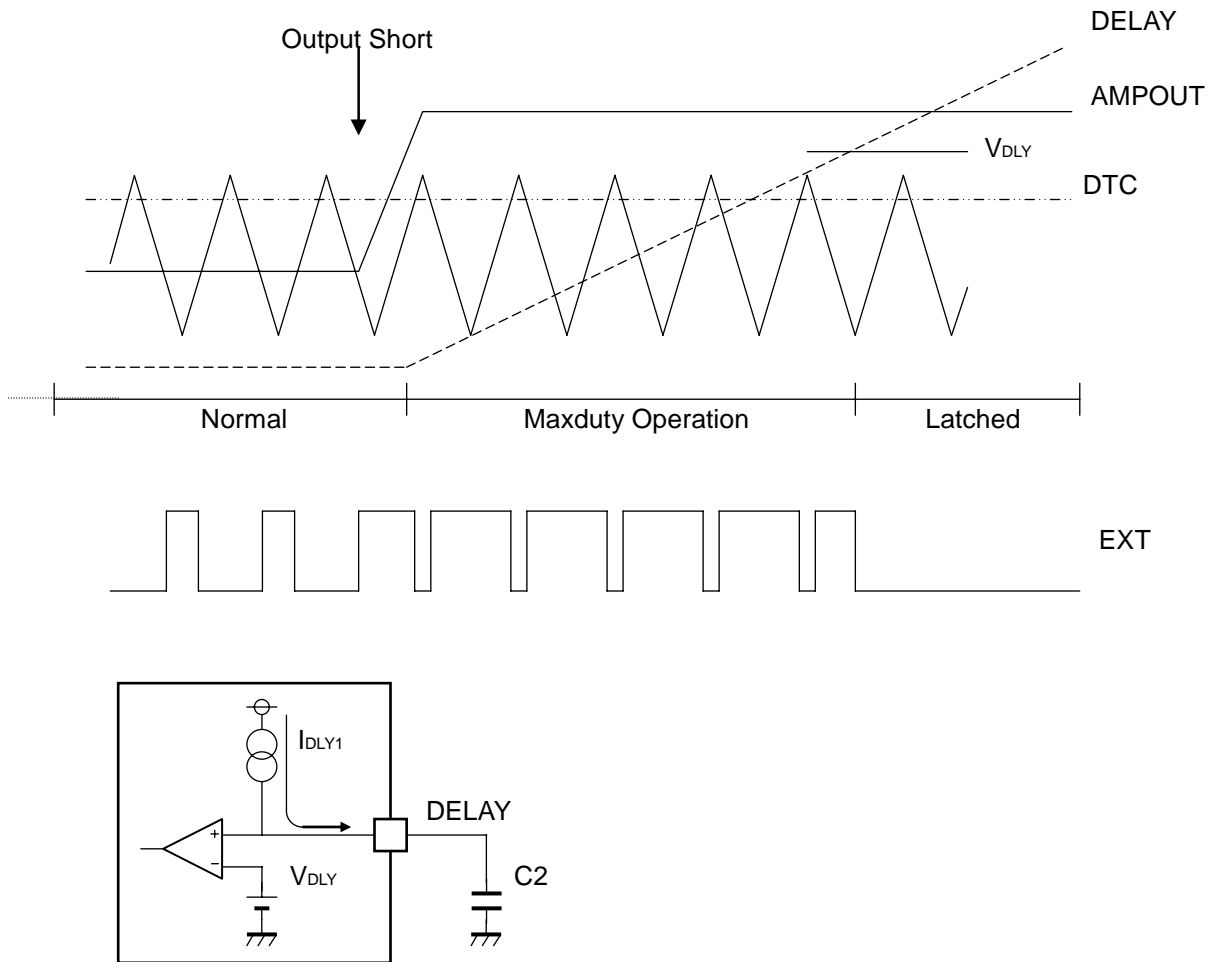

TEST CIRCUITS

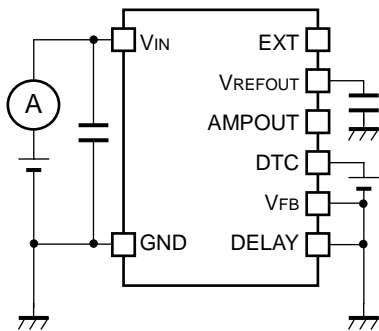

Fig.1 Consumption Current Test Circuit

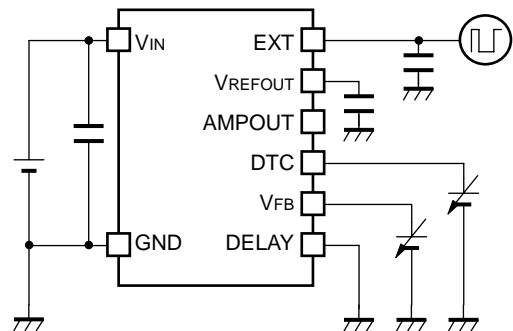

Fig.2 Oscillator Frequency, V_{FB} Voltage, Duty Cycle, EXT rising time/falling time Test Circuit

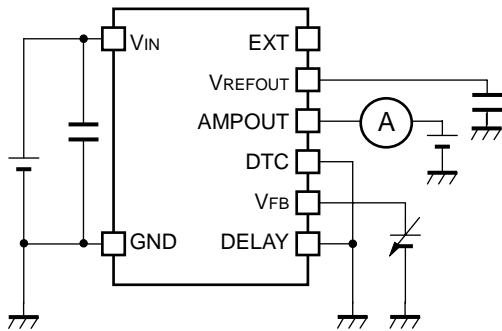

Fig.3 AMP "L" Output Current/ "H" Output Current Test Circuit

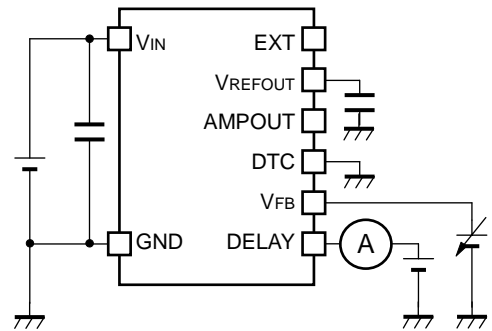

Fig.4 DELAY Pin Charge Current/ Discharge Current Test Circuit

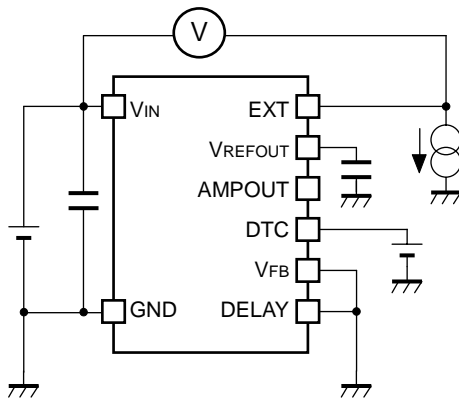

Fig.5 EXT "H" ON Resistance Test Circuit

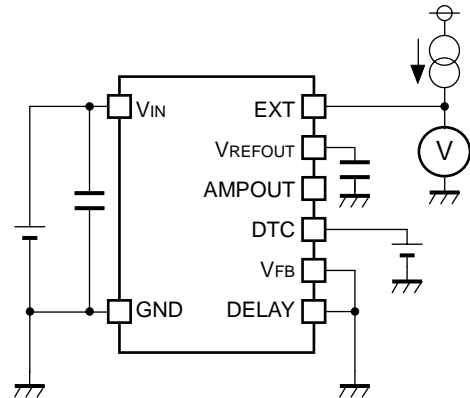

Fig.6 EXT "L" ON Resistance Test Circuit

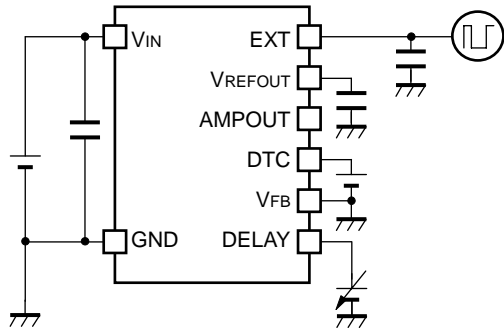

Fig.7 DELAY Pin Detector Threshold Test Circuit

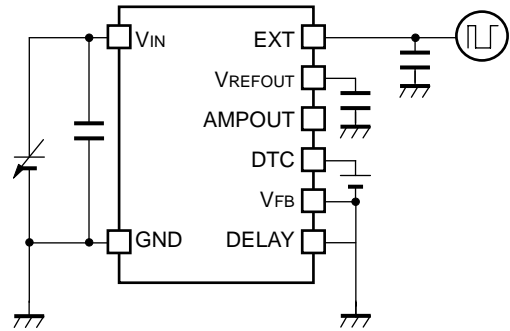

Fig.8 UVLO Detector Threshold/Released Voltage Test Circuit

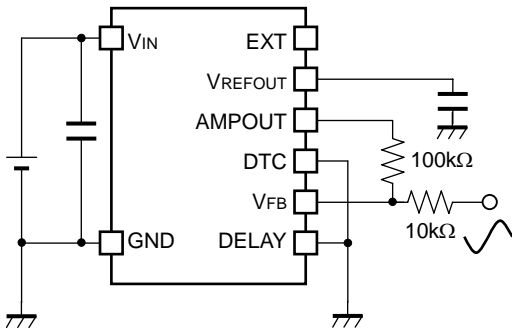

Fig.9 Error AMP Gain/Phase Test Circuit

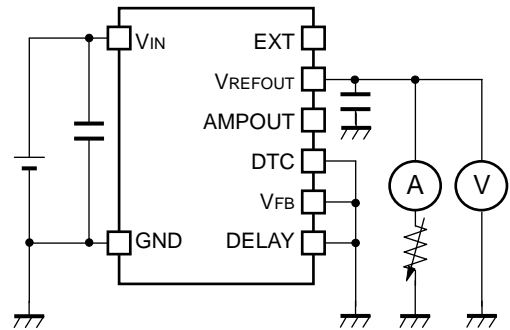

Fig.10 VREFOUT Voltage Test Current

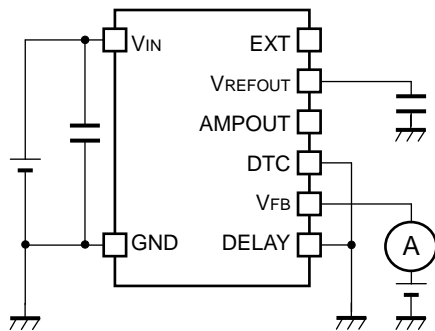
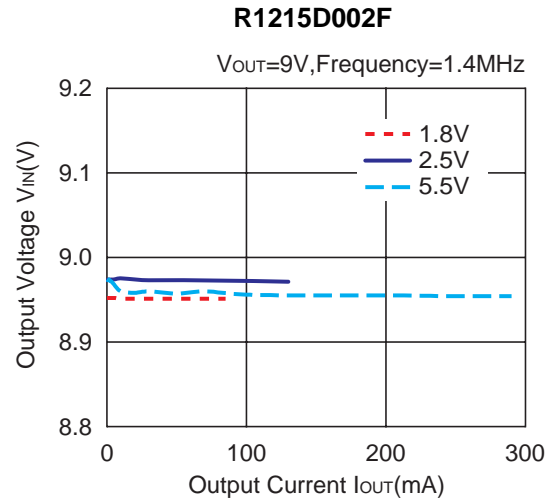
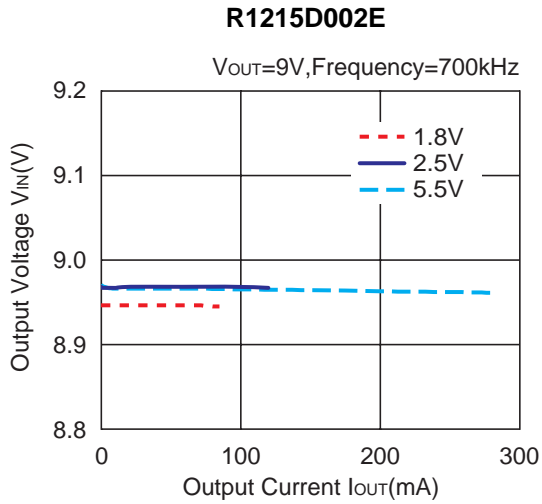

Fig.11 VFB Leakage Current Test Circuit

TYPICAL CHARACTERISTICS

1) Output Voltage vs. Output Current (Topt=25°C)



2) Efficiency vs. Output Current (Topt=25°C)

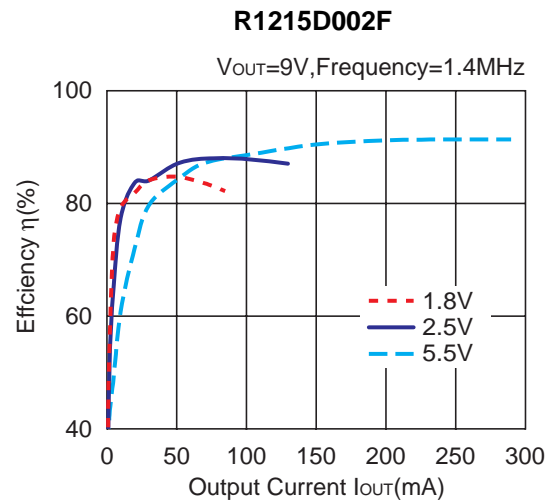
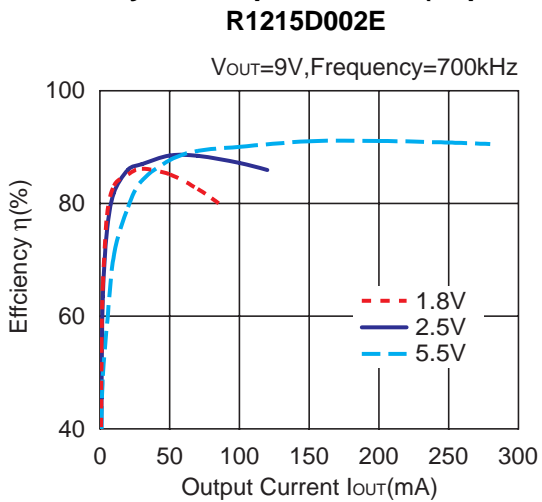

3) Supply Current vs. Temperature

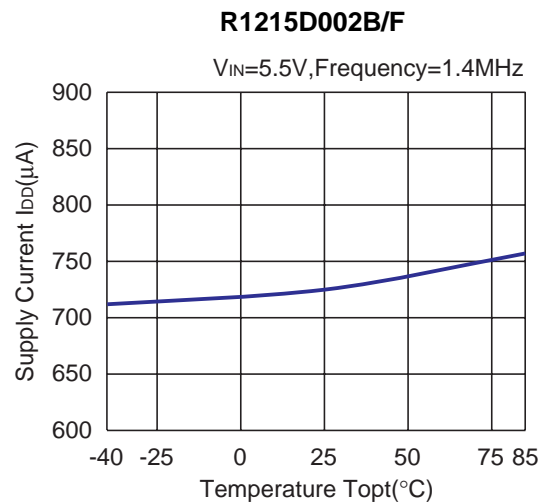
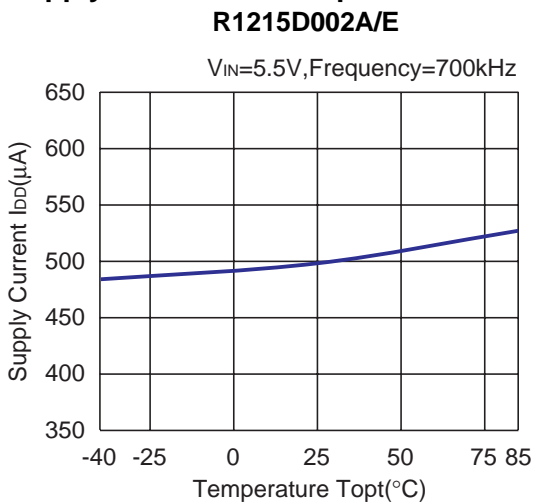

4) V_{FB} Voltage vs. Temperature
R1215D002x

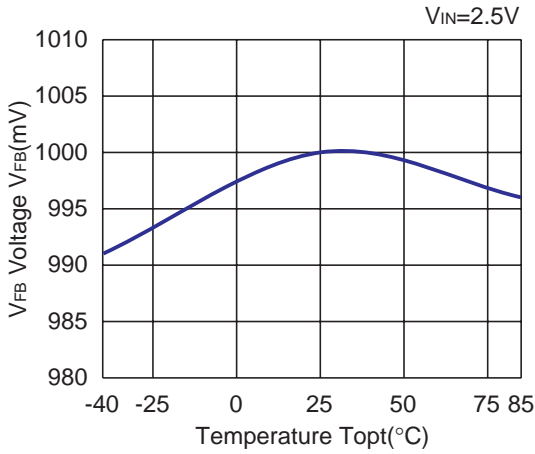

5) V_{REFOUT} Voltage vs. Temperature
R1215D002x

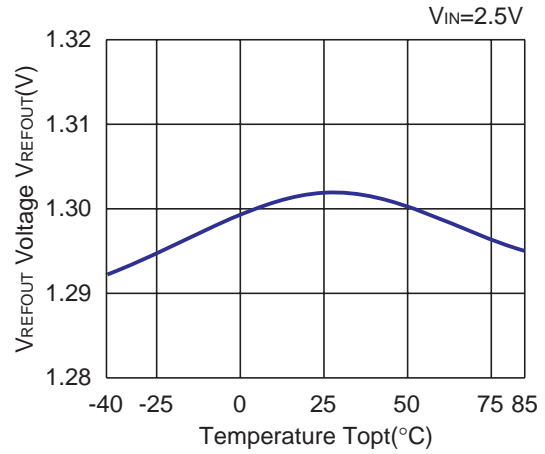

6) Oscillator Frequency vs. Temperature
R1215D002A/E

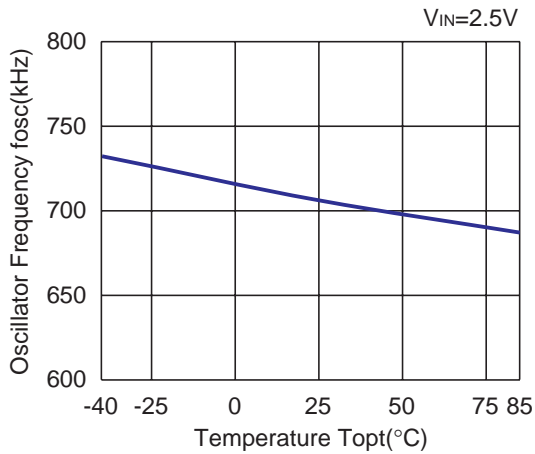

R1215D002B/F

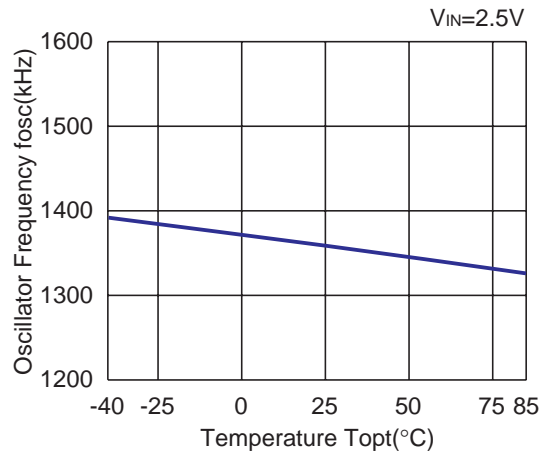

7) UVLO Detector Threshold / Released Voltage vs. Temperature
R1215D002A/B

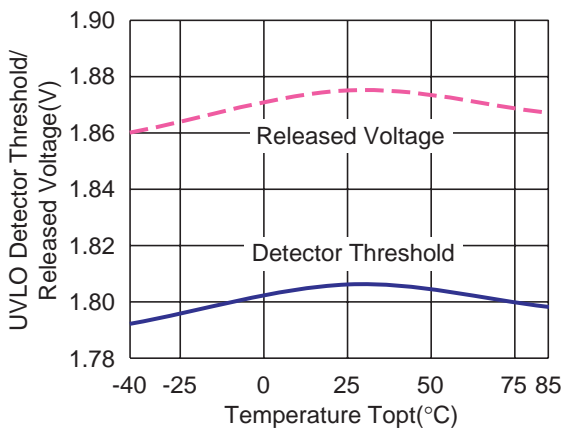

R1215D002E/F

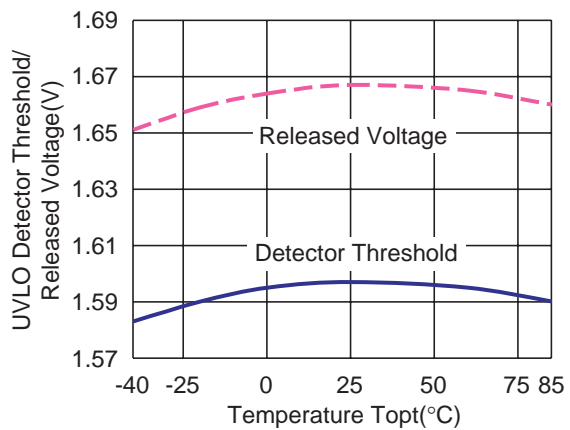

8) DELAY Pin Charge Current vs. Temperature
R1215D002x

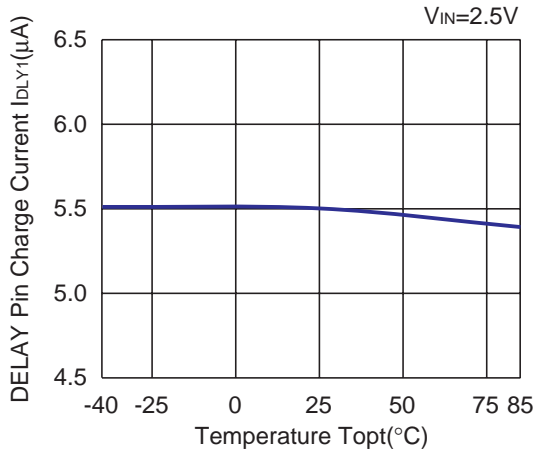

9) DELAY Pin Discharge Current vs. Temperature
R1215D002x

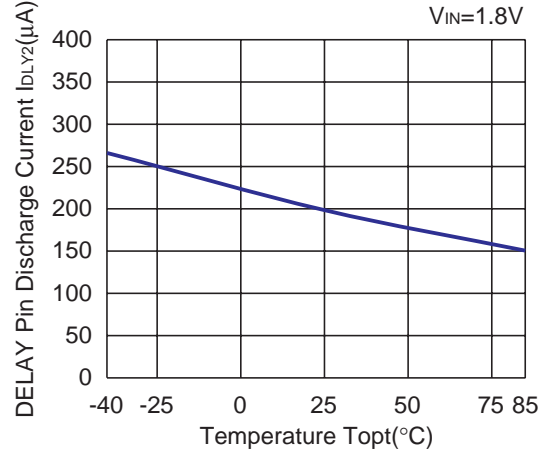

10) DELAY Pin Detector Threshold vs. Temperature
R1215D002x

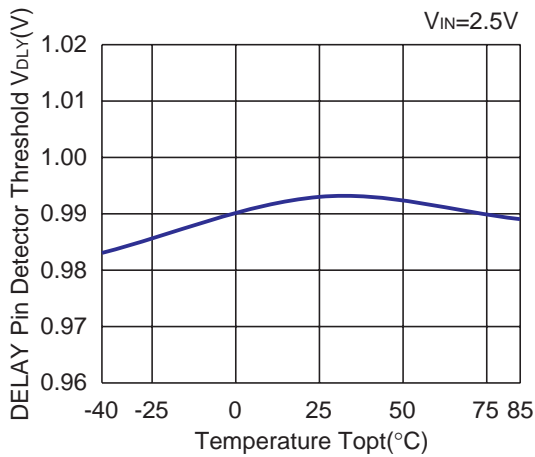

11) V_{REFOUT} Voltage vs. V_{REFOUT} Current
R1215D002x

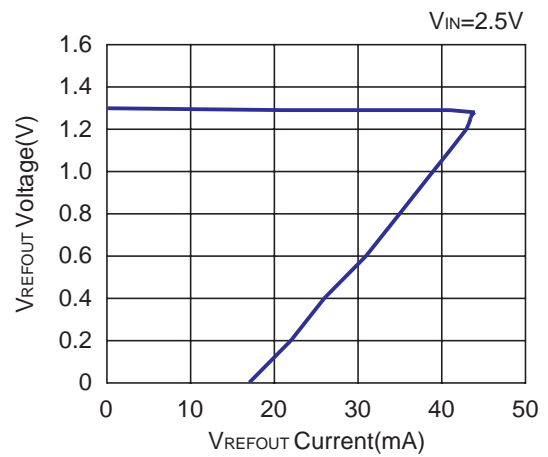

12) Maximum Duty Cycle vs. DTC Pin Voltage (T_{opt}=25°C)
R1215D002A/E

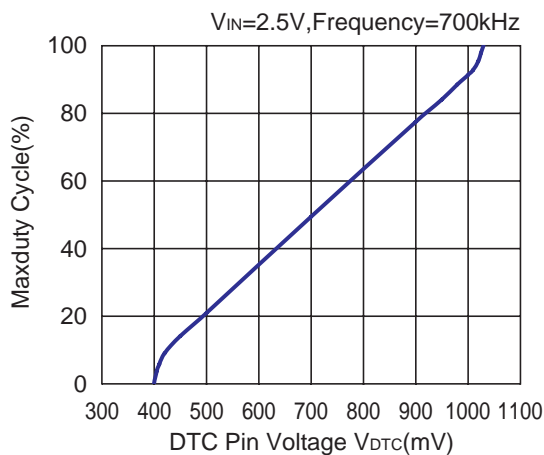

R1215D002B/F

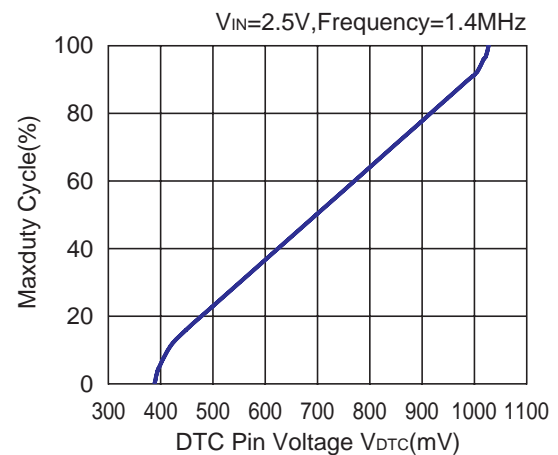

13) Error Amplifier Frequency Characteristics (Topt=25°C)

R1215D002X

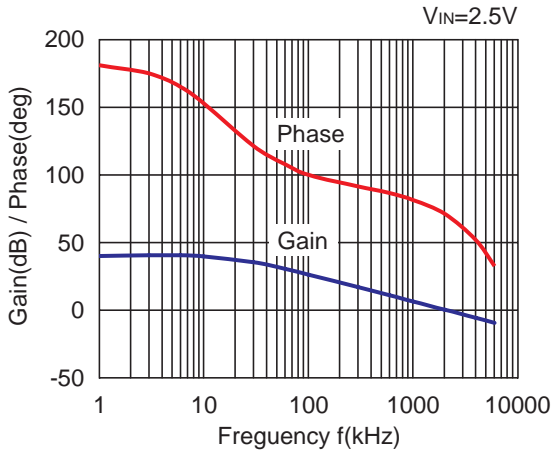

Error Amplifier

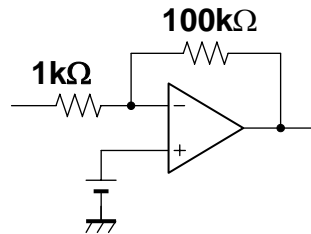

14) Load Transient Response ($V_{IN}=2.5V, T_{opt}=25^\circ C$)

R1215D002A/E

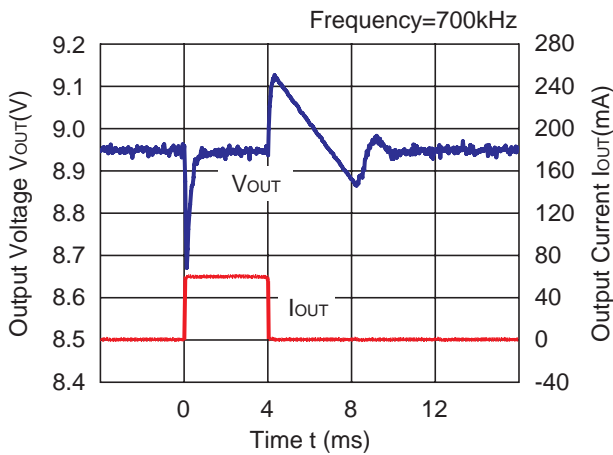

R1215D002B/F

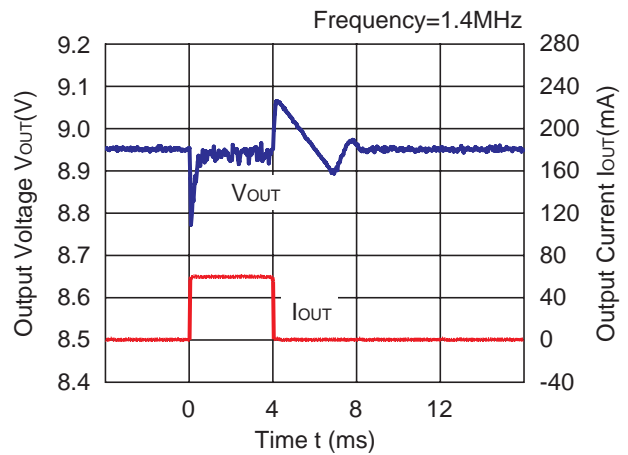

15) Power On Response ($V_{IN}=2.5V, T_{opt}=25^\circ C, R_{out}=150\Omega$)

R1215D002A/E

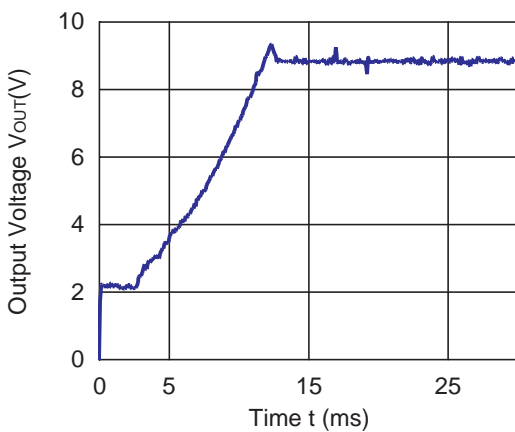

R1215D002B/F

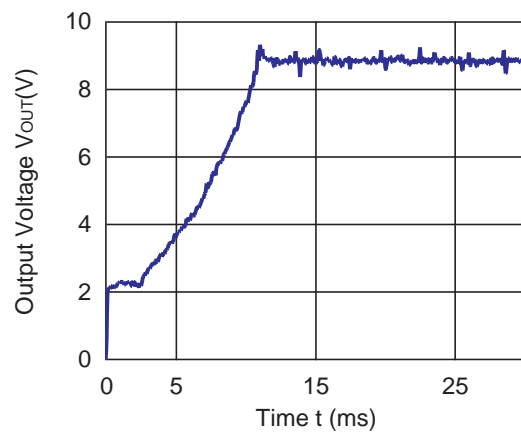



1. The products and the product specifications described in this document are subject to change or discontinuation of production without notice for reasons such as improvement. Therefore, before deciding to use the products, please refer to Ricoh sales representatives for the latest information thereon.
2. The materials in this document may not be copied or otherwise reproduced in whole or in part without prior written consent of Ricoh.
3. Please be sure to take any necessary formalities under relevant laws or regulations before exporting or otherwise taking out of your country the products or the technical information described herein.
4. The technical information described in this document shows typical characteristics of and example application circuits for the products. The release of such information is not to be construed as a warranty of or a grant of license under Ricoh's or any third party's intellectual property rights or any other rights.
5. The products listed in this document are intended and designed for use as general electronic components in standard applications (office equipment, telecommunication equipment, measuring instruments, consumer electronic products, amusement equipment etc.). Those customers intending to use a product in an application requiring extreme quality and reliability, for example, in a highly specific application where the failure or misoperation of the product could result in human injury or death (aircraft, spacevehicle, nuclear reactor control system, traffic control system, automotive and transportation equipment, combustion equipment, safety devices, life support system etc.) should first contact us.
6. We are making our continuous effort to improve the quality and reliability of our products, but semiconductor products are likely to fail with certain probability. In order to prevent any injury to persons or damages to property resulting from such failure, customers should be careful enough to incorporate safety measures in their design, such as redundancy feature, firecontainment feature and fail-safe feature. We do not assume any liability or responsibility for any loss or damage arising from misuse or inappropriate use of the products.
7. Anti-radiation design is not implemented in the products described in this document.
8. Please contact Ricoh sales representatives should you have any questions or comments concerning the products or the technical information.

RICOH COMPANY., LTD. Electronic Devices Company



■ Ricoh presented with the Japan Management Quality Award for 1999.
Ricoh continually strives to promote customer satisfaction, and shares the achievements of its management quality improvement program with people and society.



■ Ricoh awarded ISO 14001 certification.
The Ricoh Group was awarded ISO 14001 certification, which is an international standard for environmental management systems, at both its domestic and overseas production facilities. Our current aim is to obtain ISO 14001 certification for all of our business offices.

<http://www.ricoh.com/LSI/>

RICOH COMPANY, LTD. Electronic Devices Company

● Higashi-Shinagawa Office (International Sales)
3-32-3, Higashi-Shinagawa, Shinagawa-ku, Tokyo 140-8655, Japan
Phone: +81-3-5479-2857 Fax: +81-3-5479-0502

RICOH EUROPE (NETHERLANDS) B.V.

● Semiconductor Support Centre
Prof. W.H.Keesomlaan 1, 1183 DL Amstelveen, The Netherlands
P.O.Box 114, 1180 AC Amstelveen
Phone: +31-20-5474-309 Fax: +31-20-5474-791

RICOH ELECTRONIC DEVICES KOREA Co., Ltd.

11 floor, Haesung 1 building, 942, Daechidong, Gangnamgu, Seoul, Korea
Phone: +82-2-2135-5700 Fax: +82-2-2135-5705

RICOH ELECTRONIC DEVICES SHANGHAI Co., Ltd.

Room403, No.2 Building, 690#Bi Bo Road, Pu Dong New district, Shanghai 201203,
People's Republic of China
Phone: +86-21-5027-3200 Fax: +86-21-5027-3299

RICOH COMPANY, LTD. Electronic Devices Company

● Taipei office
Room109, 10F-1, No.51, Hengyang Rd., Taipei City, Taiwan (R.O.C.)
Phone: +886-2-2313-1621/1622 Fax: +886-2-2313-1623



Ricoh completed the organization of the Lead-free production for all of our products. After Apr. 1, 2006, we will ship out the lead free products only. Thus, all products that will be shipped from now on comply with RoHS Directive.