

Charge pump for White LED

RN5T649

Development Specifications

Rev. 1.2

2009/05/19

RICOH

RICOH COMPANY, LTD.
Electronic Devices Company

This specification is subject to change without notice.

Table of Contents

1. Outline	3
2. Feature	3
3. Ordering Information	3
4. Pin Configuration	4
5. Typical Application Circuit	5
6. Pin Description	6
7. Functional Blocks	7
7.1 Single Wire Serial Pulse I/F of LDO1/2	7
7.2 LDO1/2 Electrical Characteristics	8
7.3 Charge Pump	9
7.3.1 Block Diagram	9
7.3.2 Backlight LED	10
7.3.3 Protection Circuit	11
7.3.4 Unused DIN_ pin	11
7.3.5 Soft-start	11
7.3.6 Luminance Control	12
7.3.7 Single Wire Serial Pulse I/F of LED Driver	13
7.3.8 Charge Pump Electrical Characteristics	14
7.4 UVLO (Under Voltage Lock Out)	15
7.5 Thermal Shutdown Circuit	16
7.5.1 Thermal Shutdown Electrical Characteristics	16
8. Electrical Characteristics	17
8.1 Absolute Maximum Ratings	17
8.2 Recommendation of Operation Conditions	17
8.3 DC Characteristics	17
9. Package Information	18

1. Outline

RN5T649 contains a constant frequency charge pump, which is optimized for White LED application. Output enable/disable, LEDs current and LDOs ON/OFF are individually controllable through single wire serial pulse I/F.

2. Feature

- White LED Charge Pump
 - ✓ Current capability: Up to 92mA
 - ✓ 1x/1.33x/1.5x switchable charge pump mode
 - ✓ Power up four LEDs for backlight: Up to 23mA/LED
 - ✓ Luminance control with 32steps from 0.25mA to 23mA
 - ✓ Soft-start
- Power Supply Function
 - ✓ LDO (150mA) × 2 (ON/OFF control through single wire serial pulse I/F)
 - ✓ LDO output voltage is settable in 0.05V step in range of 1.2V to 3.3V
 - ✓ Over current protection (All Regulators) and thermal shutdown
- Others
 - ✓ UVLO
 - ✓ Short-circuit Protection
- Package
 - ✓ 20pin QFN package (Body size: 3.0 x 3.0 x 0.75mm, Pin pitch 0.4mm)
- Process
 - ✓ CMOS process

3. Ordering Information

RN5T649



LDO Output voltage : LDOUT1 / LDOUT2

U: 1.80V / 2.80V

V: 1.50V / 2.80V

4. Pin Configuration

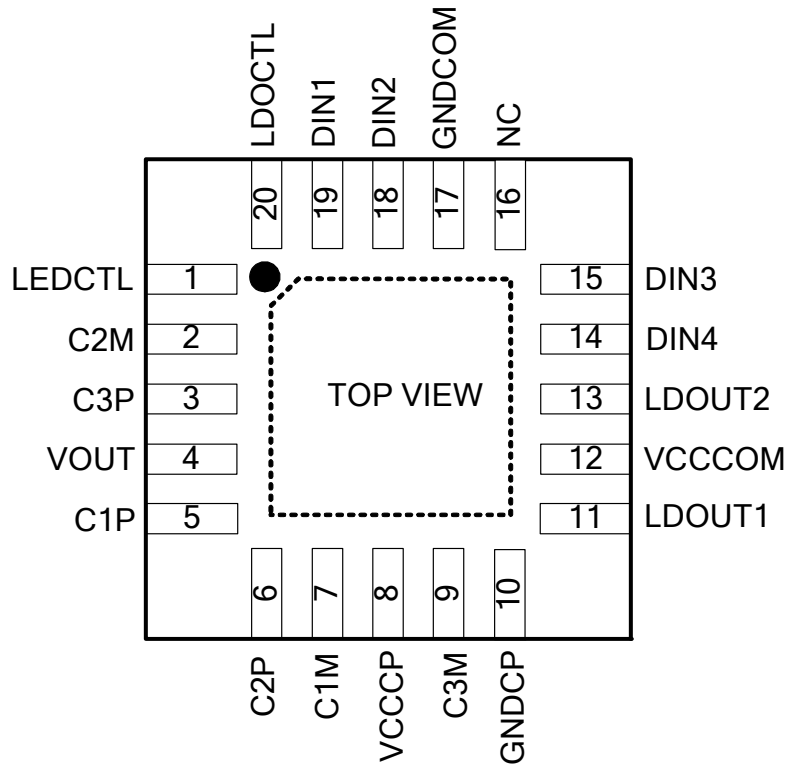

Fig 4-1 Pin Configuration

6. Pin Description

No.	Name	I/O	Description	Notes
1	LEDCTL	I	ON/OFF control and Current setting of LED driver	
2	C2M	-	Charge pump boost capacitor connection	
3	C3P	-	Charge pump boost capacitor connection	
4	VOUT	O	LED driver voltage output. VOUT is high impedance during shutdown.	
5	C1P	-	Charge pump boost capacitor connection	
6	C2P	-	Charge pump boost capacitor connection	
7	C1M	-	Charge pump boost capacitor connection	
8	VCCCP	PWR	Power supply for charge pump	
9	C3M	-	Charge pump boost capacitor connection	
10	GNDCP	GND	Ground for charge pump	
11	LDOUT1	O	Output of LDO1.	
12	VCCCOM	PWR	Power supply for LDO, UVLO, Logic block and TSHUT.	
13	LDOUT2	O	Output of LDO2	
14	DIN4	O	LED driver current control output	
15	DIN3	O	LED driver current control output	
16	NC	-	No connection	*1
17	GNDCOM	GND	Ground for LDO, UVLO, Logic block and TSHUT.	
18	DIN2	O	LED driver current control output	
19	DIN1	O	LED driver current control output	
20	LDOCTL	I	LDO1/2 ON/OFF control input	

Note*1: NC pin should be connected to GND or open.

Table 6-1 Pin Description

7. Functional Blocks

7.1 Single Wire Serial Pulse I/F of LDO1/2

RN5T649 has 2 Low Drop Output regulators, LDO1 and LDO2. At time of shipment, the output voltage can be set in 0.05 V steps by trimming.

ON/OFF operation of LDO1 and LDO2 is controllable with LDOCTL pin through single wire serial pulse I/F.

Please refer to the following timing chart. LDO1 and LDO2 are turned on after t_{OUT} ($\approx 20\mu\text{s}$ typ) when LDOCTL changes from “L” to “H”.

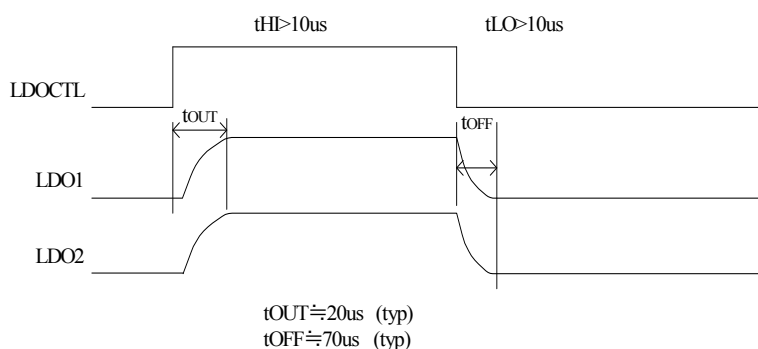

Fig 7-1 LDO ON/OFF Control 1

For the type of the bypass capacitor, it must be a ceramic type, not tantalum type, since the optimization design is based on the ceramic type for the phase compensation.

*Timer description

- t_{OUT} : If LDOCTL remains “H” more than 10us, the voltage appears to both LDO1 pin and LDO2 pin.
- t_{OFF} : “L” pulse of LDOCTL pin more than 10us turns off both LDO1 and 2.

7.2 LDO1/2 Electrical Characteristics

Unless otherwise specified, VCCCOM=3.6V, Ta=25°C, Cout=1.0uF

Symbol	Parameter	Condition	Min	Typ	Max	Units
LDOUT*1	Output Voltage Range	-	1.2		3.3	V
VACC	Output Voltage Accuracy	50uA < IOUT < 150mA, VOUT+0.5V ≤ VBATT(VCCCOM) & 3.0V ≤ VBATT(VCCCOM) ≤ 4.5V	-2%		+2%	V
IOUT	Output Current	-			150	mA
ISHT	Short Current	VOUT=0V		130		mA
VDRP	Drop-out Voltage	IOUT=150mA, Ta =85°C, VOUT ≥ 2.8V		300		mV
$\frac{\Delta V_{OUT}}{\Delta V_{CCCOM}}$	Line Regulation	VOUT+0.5V ≤ VCCCOM ≤ 4.5V IOUT=150mA		2.4		mV
$\frac{\Delta V_{OUT}}{\Delta I_{OUT}}$	Load Regulation	50uA < IOUT < 150mA		25		mV
$\frac{\Delta V_{OUT}}{\Delta T_a}$	Output Voltage Temperature Coefficient	-40°C ≤ Ta ≤ 85°C		±100		ppm/°C
RR	Ripple Rejection	f=10Hz-10kHz, Cout=1.0uF IOUT=75mA		60		dB
EN	Output Noise (RMS)	BW=100Hz-100kHz, Cout=1.0uF IOUT=75mA		50		uVrms
BC*2	Bypass Capacitor	0uA < IOUT < 150mA		1.0		uF
Icc	Consumption Current	Normal (IOUT=0mA)		70		uA
		OFF			1	

Table 7-1 LDO1/2 Electrical Characteristics

Note*1: The output voltage will be fixed (in 0.05V step) by trimming at shipment.

Note*2: For optimized phase compensation, the bypass capacitor must be a ceramic type.

7.3 Charge Pump

RN5T649 drives up to 4 white LEDs with regulated constant current. Utilizing 1x/1.33x/1.5x charge pump modes achieves high-efficiency. On/off of LED is individually controllable through single wire serial pulse I/F. Also, the luminance of LED is individually controllable through single wire serial pulse I/F.

The capacitor is highly recommended to be ceramic.

7.3.1 Block Diagram

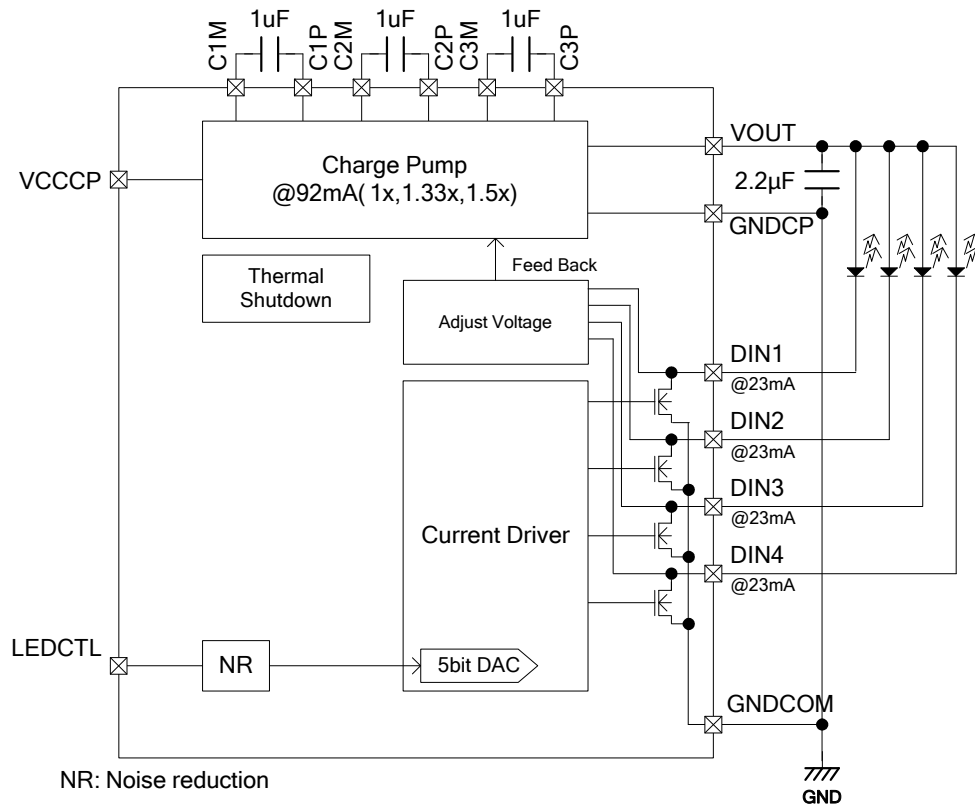

Fig 7-2 Charge Pump Circuit Diagram

7.3.2 Backlight LED

For maximized power efficiency, Charge pump operates 1x mode, 1.33x mode and 1.5x mode, where the operation mode is determined by comparing the forward voltage of each LED with the input voltage.

Initial and 1x mode

When any LED channel is enabled and VCCCP voltage is greater than Charge pump output (VOUT), Charge pump initially starts in 1x mode and VOUT is pulled up to VCCCP. During start-up, built-in Soft-start circuitry will prevent excessive inrush current. Charge pump circuit will stay in 1x mode if:

$$VOUT - Vf > 230mV \quad (1)$$

VOUT: Charge pump output

Vf: White LED forward voltage

230mV: Mode transition threshold voltage when LED output current is set at 23mA.

1x or 1.33x transition

When VCCCP falls and DIN_ pin voltage drops below the mode transition threshold voltage 230mV for 100us, Charge pump circuit switches to 1.33x mode to boost voltage. Charge pump circuit will stay in 1.33x mode if:

$$VOUT - Vf > 230mV \quad (2)$$

Every 1sec, Charge pump circuit resets to 1x mode and stays in 1x mode for approximately 100us to judge whether it changes to 1.33x mode or stays in 1x mode.

1.33x or 1.5x transition

When VCCCP falls and DIN_ pin voltage drops further below the mode transition threshold voltage 230mV for 100us, Charge pump circuit switches to 1.5x mode to boost voltage.

Every 1sec, Charge pump circuit resets to 1.33x mode and stays in 1.33x mode for approximately 100us to judge whether it changes to 1.5x mode or stays in 1.33x mode.

Mode transition

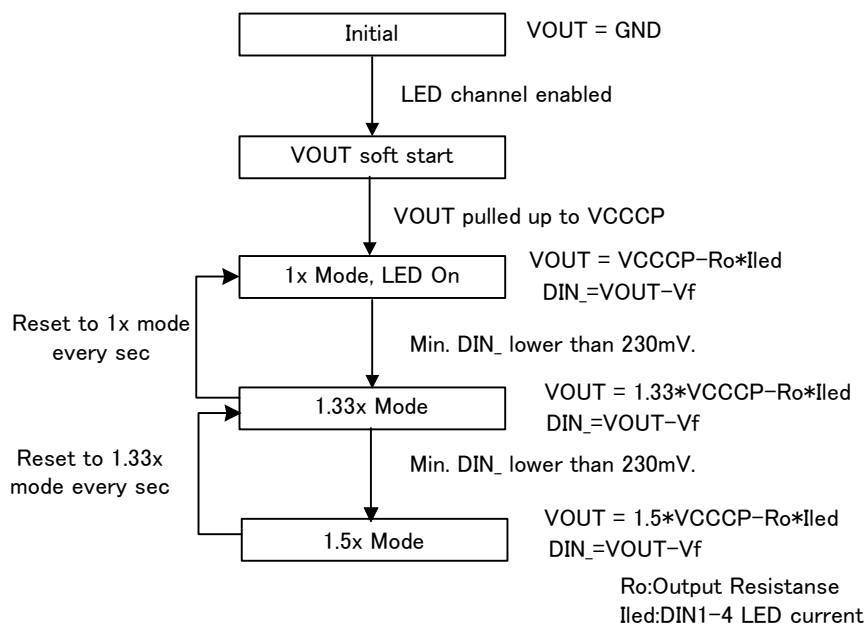

Fig 7-3 Mode Transition Diagram

7.3.3 Protection Circuit

When any DIN_ pin is floating or grounded, VOUT voltage is limited below protection voltage by gating on/off charge pump. In case any LED fails as an open circuit, VOUT voltage is also limited. Besides, when VOUT is smaller than approximately 1.2V, Charge pump will stop.

7.3.4 Unused DIN_ pin

Please ground unused DIN_ pin to avoid over-voltage protection status.

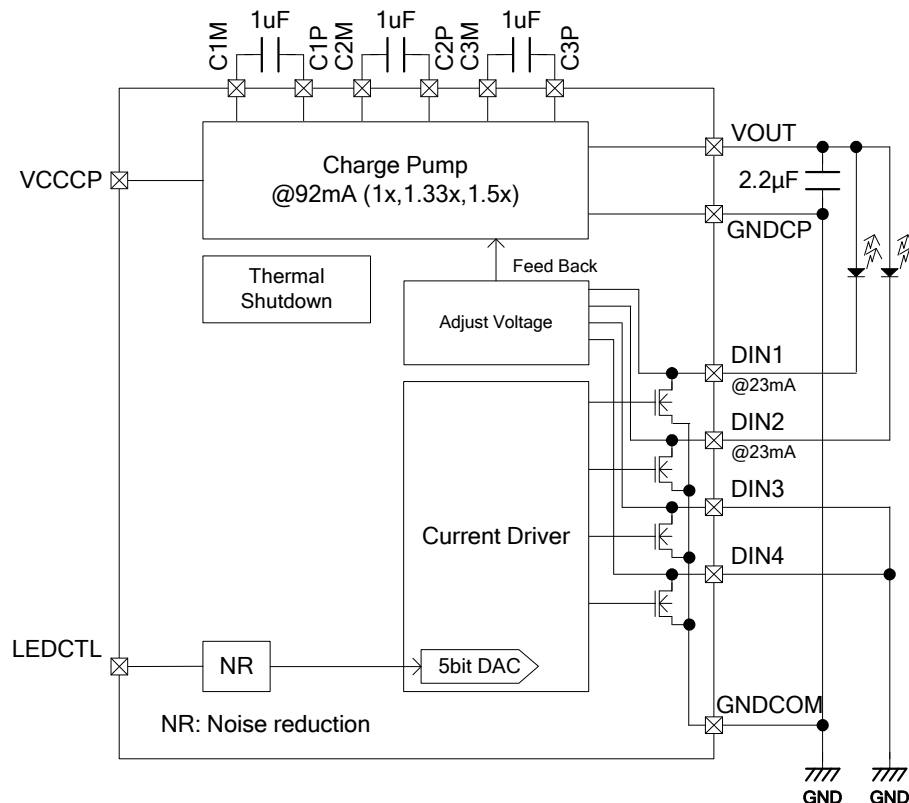

Fig 7-4 Ground Unused DIN_ pin

7.3.5 Soft-start

RN5T649 includes Soft-start circuitry to prevent excessive inrush current during turn on. (The internal resistance gradually increases, just after LEDs enabled.)

When charge pump turns on, the capacitors are charged directly from input voltage. Soft-start is achieved by the amount of capacitor available to capacitor for approximately 100us.

7.3.6 Luminance Control

RN5T649 charge pump drives 4 LEDs with regulated constant current for uniformed intensity. LEDCTL input enables/disables LED and adjusts current for each LED with 32 steps from 0.25mA to 23mA.

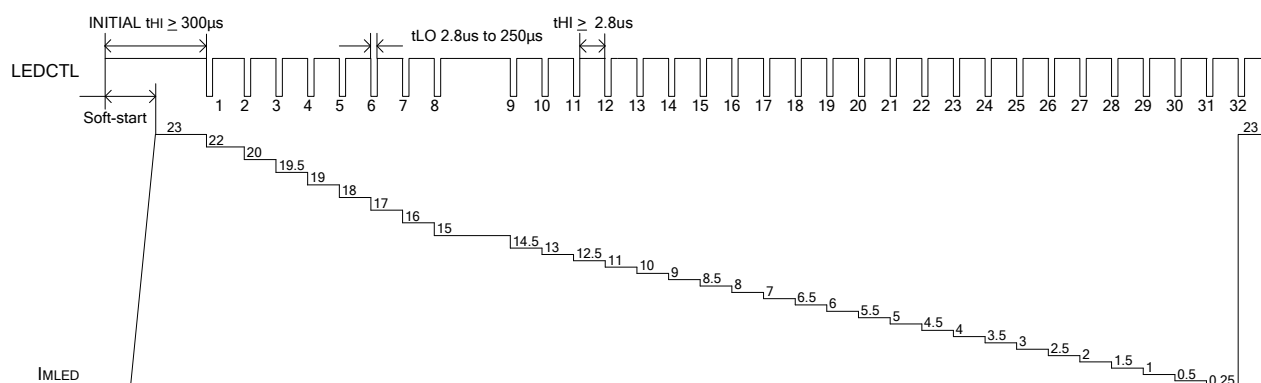

Fig 7-5 Luminance Control Diagram

- tHI : Pulling LEDCTL pin “H” for 300us or more enables LED. The minimum “H” time of LEDCTL pin is 2.8us.
- tOFF : “L” pulse of LEDCTL pin longer than 1ms turns off LED.

Luminance	Count value
OFF⇒ON(23mA)	0 (00h)
22mA	1 (01h)
20mA	2 (02h)
19.5mA	3 (03h)
19mA	4 (04h)
18mA	5 (05h)
17mA	6 (06h)
16mA	7 (07h)
15mA	8 (08h)
14.5mA	9 (09h)
13mA	10 (0Ah)
12.5mA	11 (0Bh)
11mA	12 (0Ch)
10mA	13 (0Dh)
9mA	14 (0Eh)
8.5mA	15 (0Fh)
8mA	16 (10h)
7mA	17 (11h)
6.5mA	18 (12h)
6mA	19 (13h)
5.5mA	20 (14h)
5mA	21 (15h)
4.5mA	22 (16h)
4mA	23 (17h)
3.5mA	24 (18h)
3mA	25 (19h)
2.5mA	26 (1Ah)
2mA	27 (1Bh)
1.5mA	28 (1Ch)
1mA	29 (1Dh)
0.5mA	30 (1Eh)
0.25mA	31 (1Fh)
23mA	32 (20h)
...	...

Table 7-2 LED Luminance Control

7.3.7 Single Wire Serial Pulse I/F of LED Driver

When LEDCTL goes high, LEDs are enabled at full luminance. After, the subsequent low going pulse reduces LED current in linear (1.0mA or 0.5mA) scale.

7.3.7.1 Disable LED

LED can be powered off by driving LEDCTL pin low longer than tOFF.

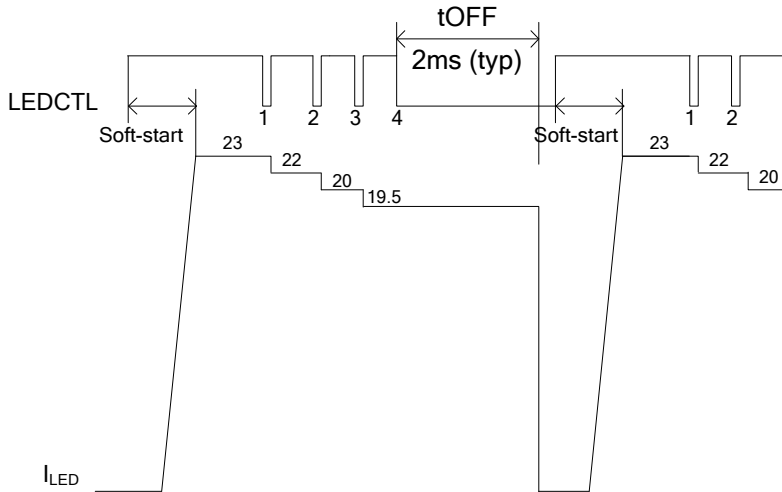

Fig 7-6 Disable LED

7.3.7.2 Initialization of LED

Luminance can be adjusted to initial value by driving LEDCTL pin “H” longer than tRESET but not over tOFF. (LED remains power-on.)

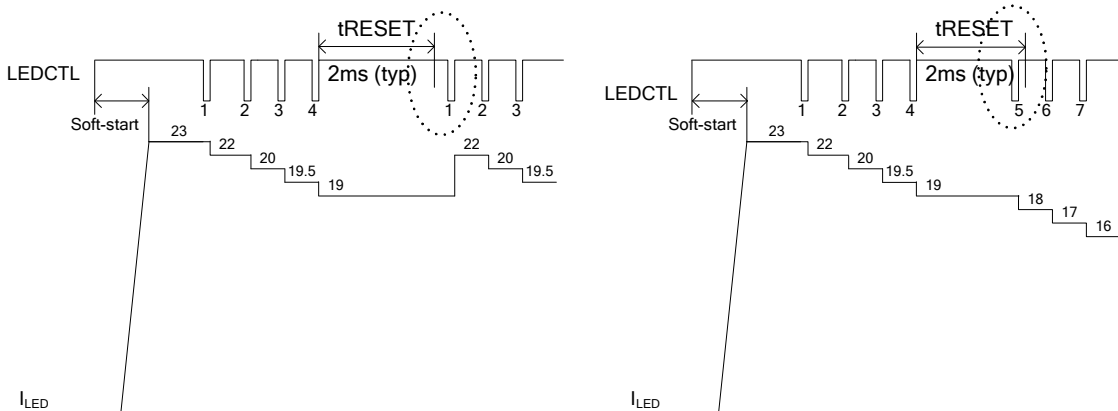

Fig 7-7 Initialization of LED

* Timer description

- tRESET timer starts at falling edge of the input clock from LEDCTL and is cleared at rising edge of input clock from LEDCTL.
- tOFF timer starts at rising/falling edge of the input clock from LEDCTL and turns off when timer overflows.

7.3.8 Charge Pump Electrical Characteristics

Unless otherwise specified, VCCCP=3.6V, VCCCOM=3.6V, Ta=25°C, C1=C2=C3=1uF, Cout=2.2uF

Symbol	Parameter	Condition	Min	Typ	Max	Units
Charge Pump						
V _{IN}	Operating Voltage	VCCCP voltage	3.0		4.5	V
I _{OUT}	Max. Output current	VCCCP ≥ 3.0V		92		mA
R _{ON}	Output resistance	1x : (VCCCP-Vout)/Iout 1.33x : (1.33xVCCCP-Vout)/Iout 1.5x : (1.5xVCCCP-Vout)/Iout		0.8 3.2 5.8		Ω
F _{OSC}	Switching Frequency	-		1.0		MHz
T _{SOFT}	Soft-start time	-		100		us
I _{CC}	Consumption Current	1x mode 1.33X mode 1.5x mode		1 5 5		mA
I _{SS}	Standby consumption current	VCCCP current			5	uA
I _{LIM}	Current limit	VOUT shorted		120		mA
V _{TH1}	1x to 1.33x transition threshold 1.33x to 1.5x transition threshold	-		230		mV
V _{TIM}	1x to 1.3x transition time 1.33x to 1.5x transition time	-		100		us
LED Driver						
I _{sink}	Maximum Sink Current	Each DIN1-4		23		mA
A _{CC}	LED current accuracy	Setting DATA Max , DIN*=0.23V	-5		5	%
I _{MAT} *1	LED current matching	Setting DATA Max , V _{diff} <0.4V	-2		2	%
V _{DROP}	Current Regulator Dropout	Setting DATA Max		230		mV
I _{LEAK}	DIN1-4 leakage in shutdown	-		0.01		uA

Table 7-3 Charge Pump Electrical Characteristics

Note*1: The matching is given by $(I_{ave} - I_{led}) / I_{ave}$. The I_{ave} means the average current of 4 LEDs.

The matching is defined without V_f voltage difference between channels.

$$I_{ave} = (I_{led1} + I_{led2} + I_{led3} + I_{led4}) / 4$$

7.4 UVLO (Under Voltage Lock Out)

Unless otherwise specified, Ta=25°C

Symbol	Parameter	Condition	Min	Typ	Max	Units
V _{Release}	Under voltage lock out threshold	VCCVIN rising		2.25		V
V _{Detect}	Under voltage lock out threshold	VCCVIN falling	2.05	2.20	2.35	V
V _{HYS}	UVLO Hysteresis	-		50		mV

Table 7-4 UVLO Electrical Characteristics

7.5 Thermal Shutdown Circuit

Overheat state can be detected by comparing the output voltages from two temperature detection circuits, which have different temperature characteristics. If the overheat state is detected, RN5T649 will turn off to protect itself from overheating.

7.5.1 Thermal Shutdown Electrical Characteristics

Unless otherwise specified, VCCCOM=3.6V, Ta=25°C

Symbol	Parameter	Condition	Min	Typ	Max	Units
T _{DET}	Detected Temperature	-		140		°C
T _{RET}	Return Temperature	-		110		°C
I _{cc}	Consumption Current	-		10		uA

Table 7-5 Thermal Shutdown Electrical Characteristics

8. Electrical Characteristics

8.1 Absolute Maximum Ratings

Symbol	Parameter	Condition	Rated value	Units
VCC_abs	Power Supply Voltage	Battery Voltage Input Pins	-0.3~6.0	V
V _{in}	Input Voltage Range	All Input Pins	-0.3~VCC*+0.3	V
PD	Package Allowable Dissipation	Mounted on Board, T _a =70°C	950	mW
T _{stg}	Storage Temperature	-	-55~+125	°C

Table 8-1 Absolute Maximum Ratings

8.2 Recommendation of Operation Conditions

Symbol	Parameter	Condition	Min	Typ	Max	Units
VCC_Op	Power Supply Voltage	Battery Voltage Input Pins (Operation Conditions)	2.7	3.6	4.5	V
VCC_Rec	Power Supply Voltage	Battery Voltage Input Pins (Recommendation of Operation Conditions)	3.0	3.6	4.5	V
T _a	Temp. of Operation	-	-40		85	°C

Table 8-2 Recommendation of Operation Conditions

8.3 DC Characteristics

Unless otherwise specified, VCCCOM=3.6V, T_a=25°C

Symbol	Parameter	Condition	Min	Typ	Max	Units
V _{ih}	“H” Input Voltage	-	1.6			V
V _{il}	“L” Input Voltage	-			0.4	V
I _{IL1}	Input Leakage Current 1	VCCCOM	-3		3	uA
I _{shut}	Shutdown Consumption Current	LDOCTL=LEDCTL=“L”		1		uA

Table 8-3 DC Characteristics

9. Package Information

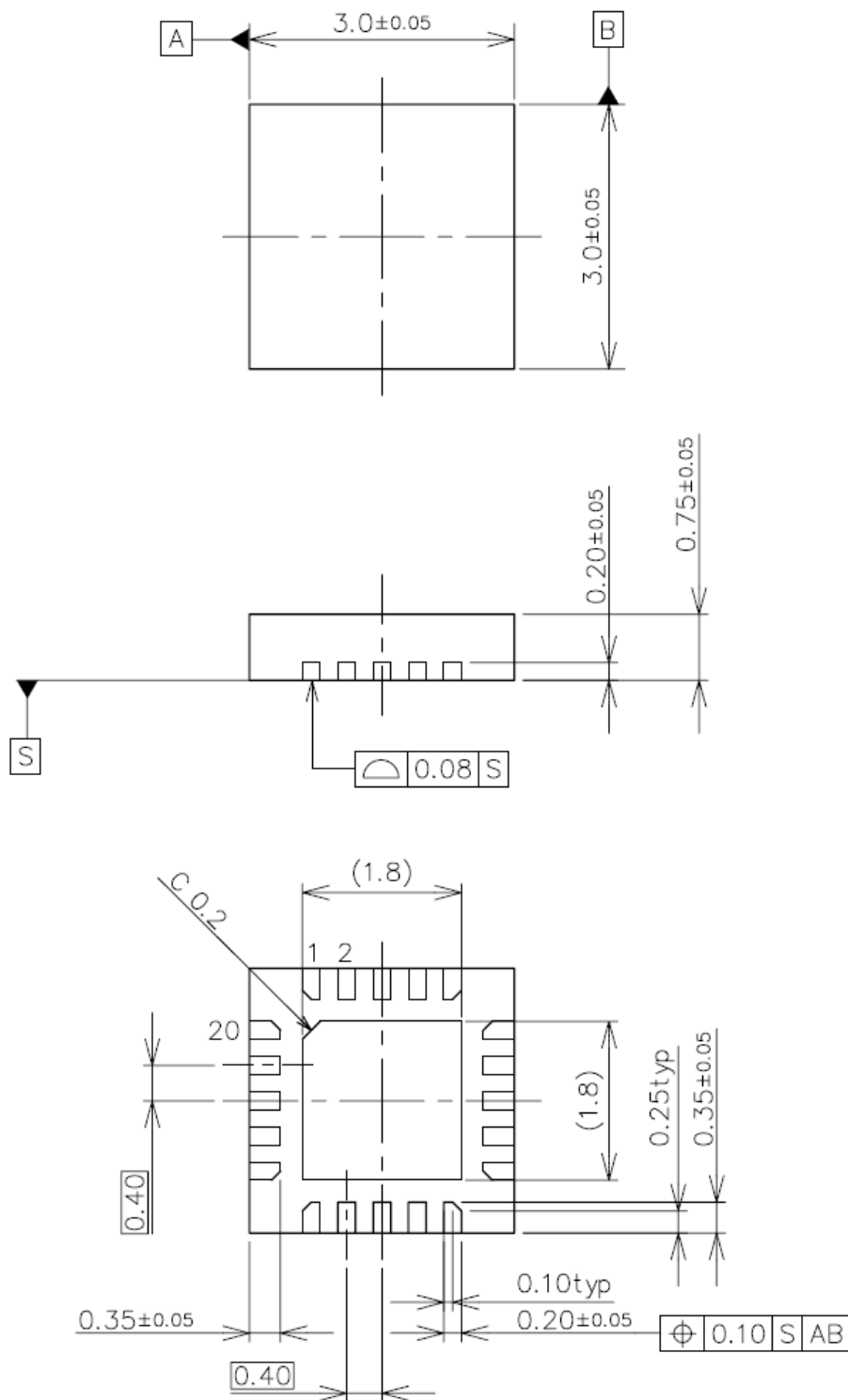

UNIT: mm